



# MPQ3364

## 4-Channel, Maximum 150mA/Ch Boost WLED Driver with 15000:1 Dimming Ratio and I<sup>2</sup>C, AEC-Q100

### DESCRIPTION

The MPQ3364 is a step-up converter with 4 channel current sources. The device is designed to drive white LED arrays as backlighting for small- or medium-sized LCD panels.

The device uses peak current mode as its PWM control architecture to regulate the boost converter. Four channel current sources are applied to the LED cathode to adjust LED brightness. The MPQ3364 regulates the current in each LED string to the value set by an external current-setting resistor, with 2.5% current regulation accuracy between strings.

A low on resistance MOSFET and headroom voltage are provided to improve efficiency. The MPQ3364 has a standard I<sup>2</sup>C digital interface for easy use. The switching frequency can be configured via a resistor, I<sup>2</sup>C interface, or external clock.

The MPQ3364 provides analog, PWM, and mix dimming modes with a PWM input. The dimming mode can be selected via the I<sup>2</sup>C interface or the MIX/AD pin. The device also has a phase shift function to eliminate noise during PWM dimming.

Robust protections are included to guarantee safe operation of the device. Protection modes include over-current protection (OCP), over-voltage protection (OVP), over-temperature protection (OTP), LED short, and LED open protection. The MPQ3364 can automatically decrease the LED current at higher temperatures.

The MPQ3364 is available in a QFN-24 (4mmx4mm) package.

### FEATURES

- 3.5V to 36V Input Voltage Range
- 4 Channels with Maximum 150mA per Channel
- Internal 100m $\Omega$ , 50V MOSFET
- Configurable  $f_{sw}$  Up to 2.2MHz
- External Sync SW Function
- Multi-Dimming Operation through PWM Input, Including:
  - Direct PWM Dimming
  - Analog Dimming
  - Mix Dimming with 25% or 12.5% Transfer Point
- 15000:1 Dimming Ratio in PWM Dimming when  $f_{PWM} \leq 200Hz$
- 200:1 Dimming Ratio during Analog Dimming through PWM Dimming Signal Input
- Excellent EMI Performance, Frequency Spread Spectrum
- I<sup>2</sup>C Interface with 3 Selectable IC Addresses
- Phase Shift Function for PWM Dimming
- 2.5% Current Matching
- Cycle-by-Cycle Current Limiting
- Disconnect VOUT from VIN
- Optional LED Current Can Automatically Decrease at Higher Temperatures
- LED Short/Open, OTP, OCP, and Inductor Short Protection
- Configurable LED Short Threshold
- Configurable OVP Threshold
- Fault Indicator Signal Output
- Available in a QFN-24 (4mmx4mm) Package
- Available in AEC-Q100 Grade 1

### APPLICATIONS

- Tablets and Notebooks
- Automotive Displays

All MPS parts are lead-free, halogen-free, and adhere to the RoHS directive. For MPS green status, please visit the MPS website under Quality Assurance. "MPS", the MPS logo, and "Simple, Easy Solutions" are trademarks of Monolithic Power Systems, Inc. or its subsidiaries.

## TYPICAL APPLICATION

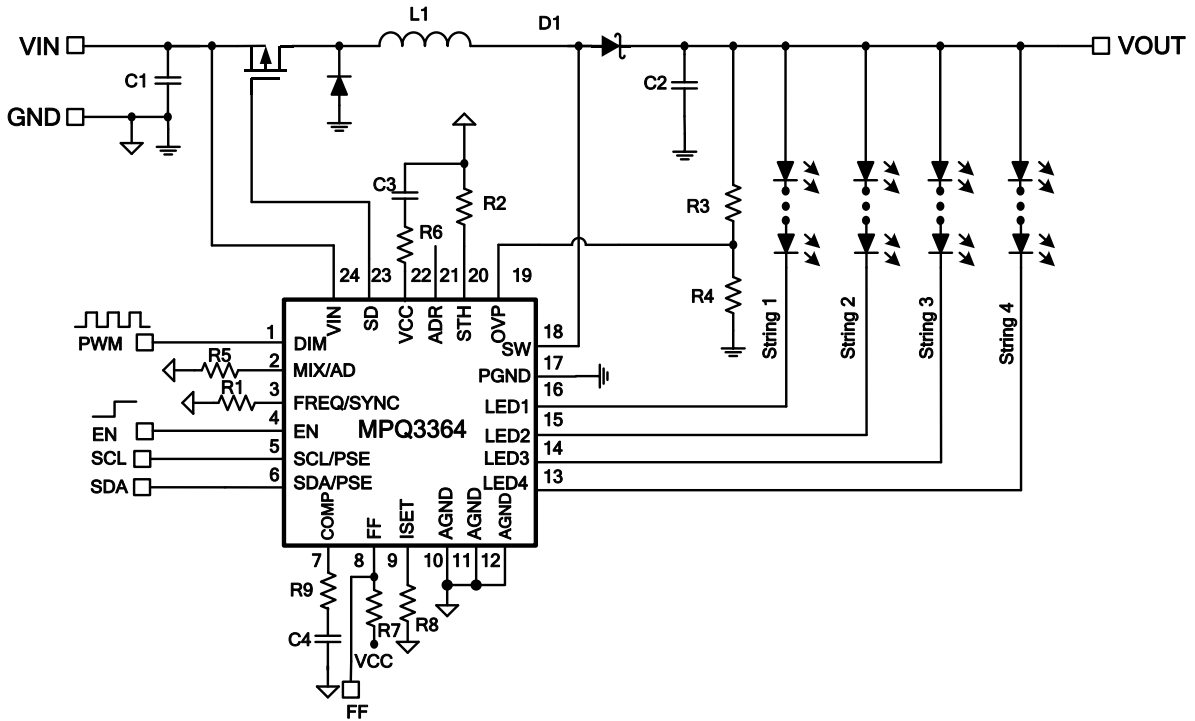

## ORDERING INFORMATION

Part Number*	Package	Top Marking	MSL Rating
MPQ3364GR-AEC1*	QFN-24 (4mmx4mm)	<i>See Below</i>	1
MPQ3364GRE-AEC1**	QFN-24 (4mmx4mm) WF	<i>See Below</i>	

\*Tape & Reel, add suffix -Z (e.g. MPQ3364GR-AEC1-Z).

\*\* For Tape & Reel, add suffix -Z (e.g. MPQ3364GRE-AEC1-Z).

### TOP MARKING (MPQ3364GR-AEC1)

MPSYWW

**MP3364**

**LLLLLL**

MPS: MPS prefix  
Y: Year code  
WW: Week code  
MP3364: Part number  
LLLLLL: Lot number

### TOP MARKING (MPQ3364GRE-AEC1)

MPSYWW

**MP3364**

**LLLLLL**

**E**

MPS: MPS prefix  
Y: Year code  
WW: Week code  
MP3364: Part number  
LLLLLL: Lot number  
E: Wettable lead flank

### PACKAGE REFERENCE

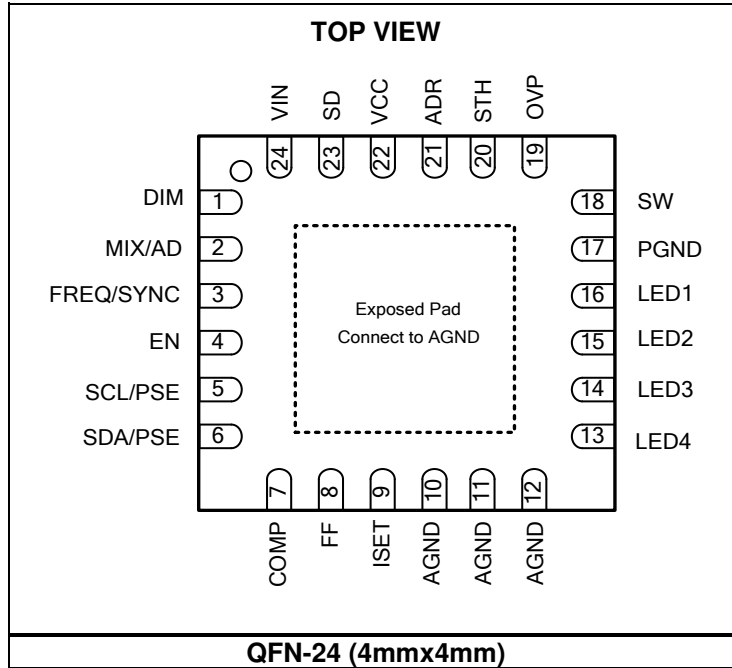

## PIN FUNCTIONS

Pin #	Name	Description
1	DIM	<b>PWM signal input pin.</b> Apply a PWM signal on the DIM pin for brightness control. DIM is pulled low internally, and a 100Hz to 20kHz PWM signal is recommended.
2	MIX/AD	<b>Dimming mode setting pin.</b> MIX/AD is a current-source output (18μA). Connect a resistor to this pin to configure its voltage. When MIX/AD is low (<0.3V), the device uses mix dimming. When MIX/AD is at a middle level (0.5V to 0.8V), the device uses PWM dimming. When MIX/AD is high (1.0V to 1.3V), the device uses analog dimming. When MIX/AD is floating, the dimming mode is set by the internal MODE register.
3	FREQ/ SYNC	<b>Switching frequency setting and SYNC pin.</b> The switching frequency is determined by the voltage and current on this pin. Connect a resistor between FREQ/SYNC and GND to set the converter's switching frequency, or connect an external clock to this pin to synchronize the boost switching frequency. Float FREQ/SYNC if the internal switching frequency is set by FSW1:0.
4	EN	<b>IC enable pin.</b> Pull EN high to enable the IC. Pull EN low to shut down the IC.
5	SCL/PSE	<b>I<sup>2</sup>C interface clock input pin.</b> Connect SDA/PSE to SCL/PSE, and pull them up between 0.75V and 1V to enable the phase shift PWM dimming function. If the phase-shift function and I <sup>2</sup> C are not used, pull this pin to GND. Do not float this pin.
6	SDA/PSE	<b>I<sup>2</sup>C interface data input pin.</b> Connect SDA/PSE to SCL/PSE, and pull them up between 0.75V and 1V to enable the phase shift PWM dimming function. If the phase-shift function and I <sup>2</sup> C are not used, pull this pin to GND. Do not float this pin.
7	COMP	<b>Compensation pin.</b>
8	FF	<b>Fault flag pin.</b> Open drain during normal operation. FF is pulled low if a fault occurs.
9	ISET	<b>LED current setting.</b> Tie a current-setting resistor from ISET to GND to configure the current in each LED string.
10, 11, 12	AGND	<b>Analog ground.</b>
13	LED4	<b>LED string 4 current input.</b> Connect the LED string 4 cathode to this pin.
14	LED3	<b>LED string 3 current input.</b> Connect the LED string 3 cathode to this pin.
15	LED2	<b>LED string 2 current input.</b> Connect the LED string 2 cathode to this pin.
16	LED1	<b>LED string 1 current input.</b> Connect the LED string 1 cathode to this pin.
17	PGND	<b>Step-up converter power ground.</b>
18	SW	<b>Drain for the internal low-side MOSFET switch.</b> Connect the power inductor to SW.
19	OVP	<b>Over-voltage protection pin.</b> Connect a resistor divider from the OVP pin to GND to configure the over-voltage protection threshold.
20	STH	<b>Short LED protection threshold setting pin.</b> STH is a current-source output (18μA). Connect a resistor to this pin to configure its voltage. Float STH if the internal short LED protection threshold is set by TH_S1:0.
21	ADR	<b>IC address setting pin.</b> Connect a resistor to this pin to set the IC address. When ADR is floating, the IC address is 0x38. When ADR < 0.4V, the IC address is 0x3A. When ADR is between 0.4V and 1.4V, the IC address is 0x39. The ADR pin's pull-up current is 18μA.
22	VCC	<b>5V LDO output pin.</b> VCC provides power to the internal logic and gate driver. Place a ceramic capacitor as close to this pin as possible to reduce noise.
23	SD	<b>External disconnect P-channel MOSFET (PMOS) gate drive pin.</b> Turn off the external PMOS if a fault occurs. Float this pin if it is not used.
24	VIN	<b>Power supply input.</b> VIN supplies power to the IC.
Exposed pad	AGND	<b>Chip ground.</b> Connect the exposed pad to AGND.

**ABSOLUTE MAXIMUM RATINGS** <sup>(1)</sup>

V <sub>IN</sub> .....	-0.3V to +42V
V <sub>SW</sub> , V <sub>LED1</sub> to V <sub>LED4</sub> .....	-0.5V to +50V
V <sub>SW</sub> .....	-1.0V for <100ns
V <sub>SD</sub> .....	V <sub>IN</sub> - 6V to V <sub>IN</sub>
All other pins.....	-0.3V to +6V
Junction temperature .....	150°C
Lead temperature .....	260°C
Storage temperature.....	-65°C to +150°C
Continuous power dissipation (T <sub>A</sub> = 25°C) <sup>(2)</sup>	
QFN-24 (4mmx4mm).....	2.97W

**ESD Ratings**

Human body model (HBM)	
LED1~4 ESD.....	±7kV
All other pins .....	±4kV
Charged device model (CDM) .....	±2kV

**Recommended Operating Conditions** <sup>(3)</sup>

Supply voltage (V <sub>IN</sub> ) .....	3.5V to 36V
Operating junction temp.....	-40°C to +125°C

<b>Thermal Resistance</b> <sup>(4)</sup>	<b>θ<sub>JA</sub></b>	<b>θ<sub>JC</sub></b>	
QFN-24 (4mmx4mm).....	42.....	9.....	°C/W

**Notes:**

- 1) Exceeding these ratings may damage the device.
- 2) The maximum allowable power dissipation is a function of the maximum junction temperature T<sub>J</sub> (MAX), the junction-to-ambient thermal resistance θ<sub>JA</sub>, and the ambient temperature T<sub>A</sub>. The maximum allowable continuous power dissipation at any ambient temperature is calculated by P<sub>D</sub> (MAX) = (T<sub>J</sub> (MAX) - T<sub>A</sub>) / θ<sub>JA</sub>. Exceeding the maximum allowable power dissipation can cause excessive die temperature, and the regulator may go into thermal shutdown. Internal thermal shutdown circuitry protects the device from permanent damage.
- 3) The device is not guaranteed to function outside of its operating conditions.
- 4) Measured on JESD51-7, 4-layer PCB.

## ELECTRICAL CHARACTERISTICS

V<sub>IN</sub> = 12V, V<sub>EN</sub> = 2V, T<sub>J</sub> = -40°C to +125°C, typical value is at T<sub>J</sub> = 25°C, unless otherwise noted.

Parameter	Symbol	Condition	Min	Typ	Max	Units
Operating input voltage	V <sub>IN</sub>		3.5		36	V
Quiescent supply current	I <sub>Q</sub>	No switching		5		mA
Shutdown supply current	I <sub>ST</sub>	V <sub>EN</sub> = 0V, V <sub>IN</sub> = 12V			1	μA
Input UVLO threshold	V <sub>IN_UVLO</sub>	Rising edge		3.1		V
Input UVLO hysteresis				100		mV
LDO output voltage	V <sub>CC</sub>	V <sub>EN</sub> = 2V, 6V < V <sub>IN</sub> < 24V, 0mA < I <sub>VCC</sub> < 10mA		5		V
EN on threshold	V <sub>EN_ON</sub>	V <sub>EN</sub> rising	1.2			V
EN off threshold	V <sub>EN_OFF</sub>	V <sub>EN</sub> falling			0.4	V
EN pull-down resistance	R <sub>EN</sub>			1		MΩ
<b>Step-Up Converter</b>						
Low-side MOSFET on resistance	R <sub>DS(ON)_LS</sub>	V <sub>IN</sub> = 12V		100		mΩ
SW leakage current	I <sub>SW_LK</sub>	V <sub>SW</sub> = 45V			1	μA
Switching frequency	f <sub>SW</sub>	R <sub>FREQ</sub> = 10kΩ	1.98	2.2	2.42	MHz
		R <sub>FREQ</sub> = 40kΩ	495	550	605	kHz
		FSW1:0 = 01, FREQ floating	340	400	460	kHz
FREQ voltage	V <sub>FREQ</sub>		0.57	0.6	0.63	V
ADR pull-up current	I <sub>ADR</sub>			18		μA
Maximum duty cycle	D <sub>MAX</sub>	f <sub>SW</sub> = 1MHz	90			%
Cycle-by-cycle current limiting	I <sub>SW_LIMIT</sub>	T <sub>J</sub> = +25°C and -40°C, Duty = 90%	5.5	7		A
		T <sub>J</sub> = 125°C, duty = 90%	4.5	5.5		A
Current limit protection	I <sub>CL</sub>	To trigger current limit protection		12		A
SYNC input low threshold	V <sub>SYNC_LO</sub>	V <sub>SYNC</sub> falling			0.4	V
SYNC input high threshold	V <sub>SYNC_HI</sub>	V <sub>SYNC</sub> rising	1.2			V
PSE active threshold	V <sub>PSE</sub>	Phase shift enabled	0.75	0.9	1.0	V
COMP trans-conductance	G <sub>COMP</sub>	ΔI <sub>COMP</sub> ≤ 10μA		100		μA/V
COMP source current limit	I <sub>COMP_SO</sub>			90		μA
COMP sink current limit	I <sub>COMP_SI</sub>			30		μA
<b>Current Dimming</b>						
DIM input low threshold	V <sub>DIM_LO</sub>	V <sub>DIM</sub> falling			0.4	V
DIM input high threshold	V <sub>DIM_HI</sub>	V <sub>DIM</sub> rising	1.2			V
MIX/AD input low threshold	V <sub>MIX_LO</sub>	Mix dimming threshold			0.3	V
MIX/AD input middle threshold	V <sub>MIX_MID</sub>	PWM dimming threshold	0.5		0.8	V
MIX/AD input high threshold	V <sub>MIX_HI</sub>	Analog dimming threshold	1.0		1.3	V

**ELECTRICAL CHARACTERISTICS (continued)**
 $V_{IN} = 12V$ ,  $V_{EN} = 2V$ ,  $T_J = -40^{\circ}C$  to  $+125^{\circ}C$ , typical value is at  $T_J = 25^{\circ}C$ , unless otherwise noted.

Parameter	Symbol	Condition	Min	Typ	Max	Units
MIX/AD pull-up current	$I_{MIX}$	MIX/AD pull-up current		18		$\mu A$
Mix dimming transfer point		MIXTP bit = 0		25		%
Transfer point hysteresis				0.5		%
Mix dimming output dimming frequency	$f_{MIX}$	MIXFR bit = 0		200		Hz
<b>LED Current Regulator</b>						
LEDx regulation voltage	$V_{HD}$	$I_{LED} = 20mA$		350		mV
		$I_{LED} = 100mA$		850	1000	mV
Current matching <sup>(5)</sup>		$I_{LED} = 20mA$	-2.5		+2.5	%
		$I_{LED} = 100mA$	-2.5		+2.5	%
ISET voltage	$V_{ISET}$			1.2		V
LED current	$I_{LED}$	$R_{ISET} = 24.9k\Omega$ , $T_J = 25^{\circ}C$	48.75	50	51.25	mA
		$I_{LED} = 1 / 50 \times 50mA = 1mA$	0.9	1.05	1.2	mA
Phase shift degree		LED1 to 4 enable		90		$^{\circ}$
<b>Protection</b>						
Over-voltage protection (OPV) threshold	$V_{OVP}$		1.9	2	2.1	V
OVP hysteresis				200		mV
OVP UVLO threshold	$V_{OVP\_UV}$	Step-up converter fails		100		mV
LEDx over-voltage (OV) threshold	$V_{LEDX\_OV}$	LEDx bits = 01		5		V
LEDx OV fault timer				7.7		ms
LEDx UVLO threshold	$V_{LEDX\_UV}$			100		mV
Thermal shutdown threshold <sup>(6)</sup>	$T_{ST}$	Rising edge		170		$^{\circ}C$
		Hysteresis		20		$^{\circ}C$
SD pull-down current	$I_{SD}$			60		$\mu A$
SD voltage (relative to $V_{IN}$ )	$V_{SD-IN}$	$V_{IN} = 12V$ , $V_{IN} - V_{SD}$		6		V
STH pull-up current	$I_{STH}$	STH pull-up current		18		$\mu A$
<b>I<sup>2</sup>C Interface</b>						
Input logic low	$V_{IL}$				0.4	V
Input logic high	$V_{IH}$		1.2			V
Output logic low	$V_{OL}$	$I_{LOAD} = 3mA$			0.4	V
SCL clock frequency	$f_{SCL}$				400	kHz
SCL high time	$t_{HIGH}$		0.6			$\mu s$
SCL low time	$t_{LOW}$		1.3			$\mu s$
Data set-up time	$t_{SU\_DAT}$		100			ns
Data hold time	$t_{HD\_DAT}$		0		0.9	$\mu s$
Set-up time for a repeated start	$t_{SU\_STA}$		0.6			$\mu s$



## ELECTRICAL CHARACTERISTICS (continued)

V<sub>IN</sub> = 12V, V<sub>EN</sub> = 2V, T<sub>J</sub> = -40°C to +125°C, typical value is at T<sub>J</sub> = 25°C, unless otherwise noted.

Parameter	Symbol	Condition	Min	Typ	Max	Units
Start hold time	t <sub>HD_STA</sub>		0.6			μs
Bus free time between a start and stop condition	t <sub>BUF</sub>		1.3			ms
Set-up time for a stop condition	t <sub>SU_STO</sub>		0.6			μs
SCL and SDA rise time	t <sub>R</sub>		20 + 0.1 × C <sub>B</sub>		300	ns
SCL and SDA fall time	t <sub>F</sub>		20 + 0.1 × C <sub>B</sub>		300	ns
Pulse width of suppressed spike	t <sub>SP</sub>		0		50	ns
Capacitance bus for each bus line	C <sub>B</sub>				400	pF

## I<sup>2</sup>C-COMPATIBLE INTERFACE TIMING DIAGRAM

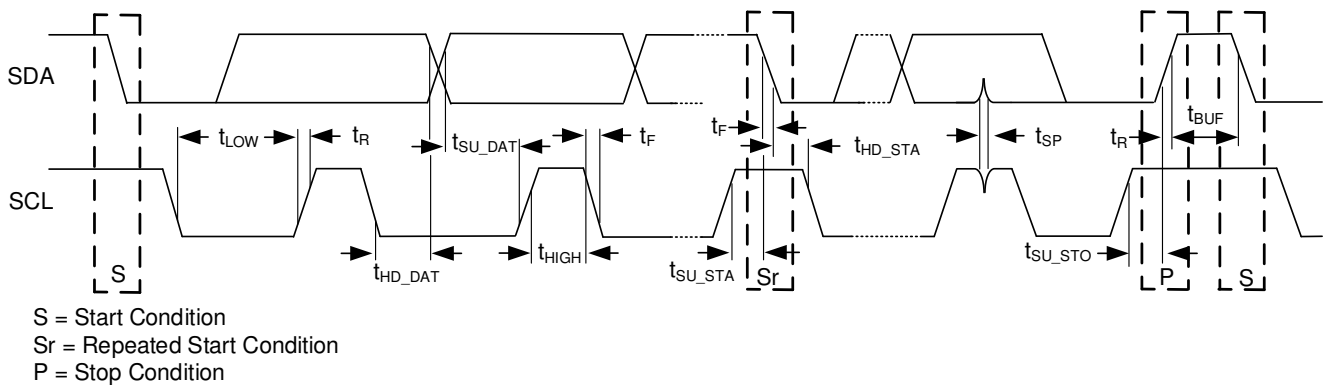

### Notes:

- 5) Matching is defined as the difference between the maximum current and minimum current, divided by 2 times the average current.
- 6) Guaranteed by design.

## TYPICAL PERFORMANCE CHARACTERISTICS

V<sub>IN</sub> = 12V, L = 22μH, LED = 4P/12S, f<sub>SW</sub> = 400kHz, I<sub>SET</sub> = 75mA, T<sub>A</sub> = 25°C, unless otherwise noted.

### Steady State

f<sub>sw</sub> = 400kHz

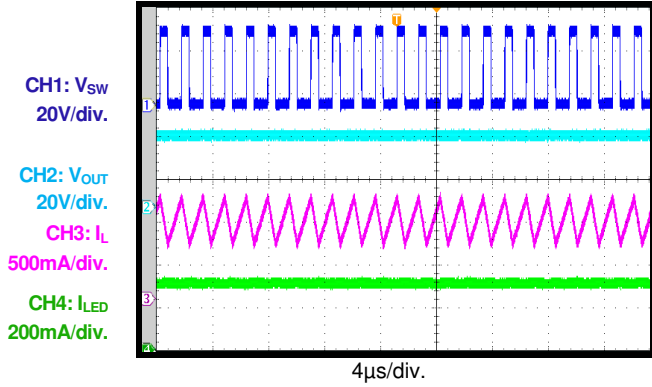

### Steady State

f<sub>sw</sub> = 2.2MHz

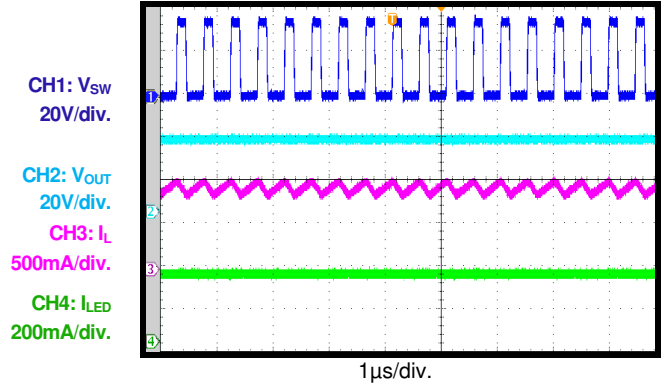

### Start-Up through VIN

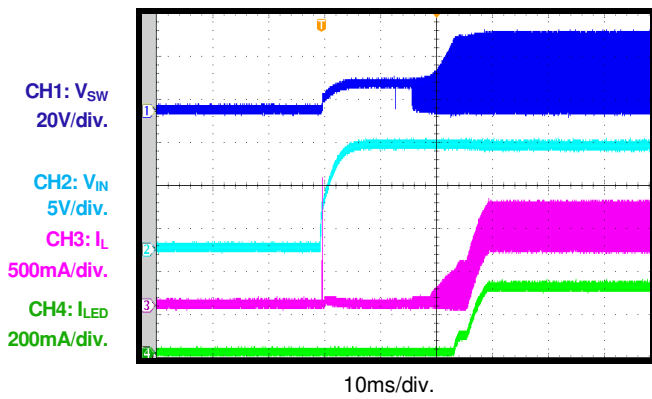

### Start-Up through EN

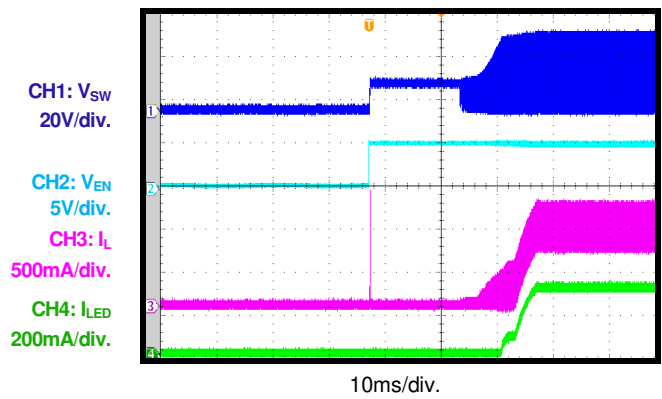

### PWM Dimming

f<sub>PWM</sub> = 200Hz, D<sub>PWM</sub> = 50%

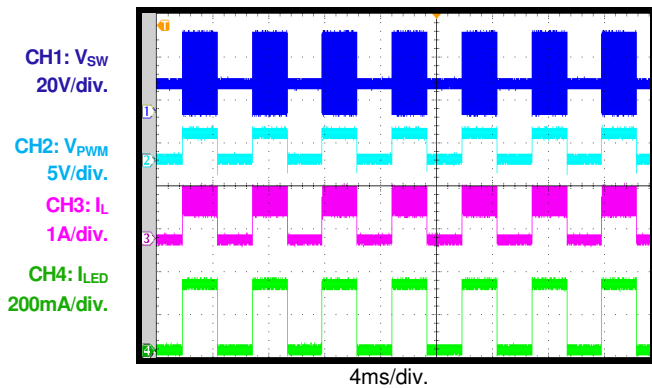

### PWM Dimming

f<sub>PWM</sub> = 20kHz, D<sub>PWM</sub> = 50%

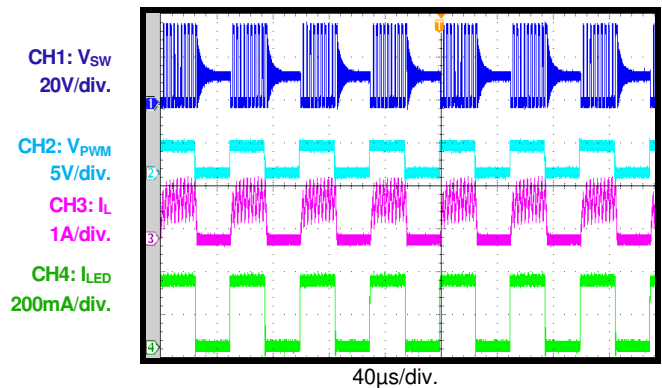

**TYPICAL PERFORMANCE CHARACTERISTICS (continued)**
 $V_{IN} = 12V$ ,  $L = 22\mu H$ , LED = 4P/12S,  $f_{SW} = 400kHz$ ,  $I_{SET} = 75mA$ ,  $T_A = 25^\circ C$ , unless otherwise noted.

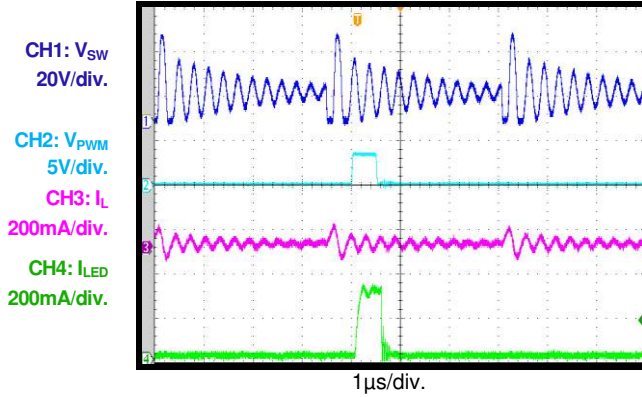
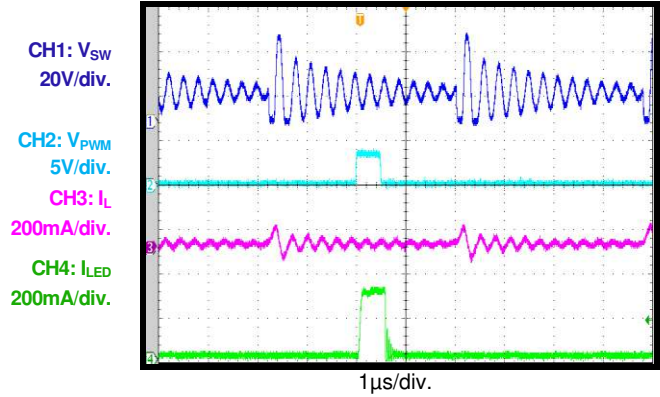
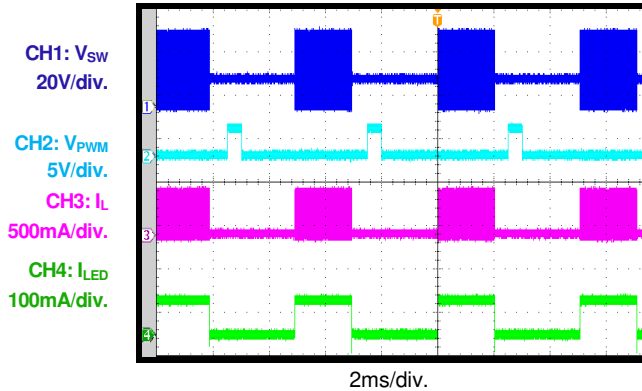
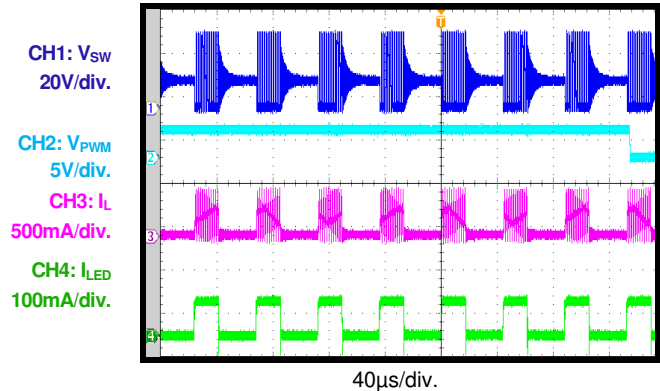
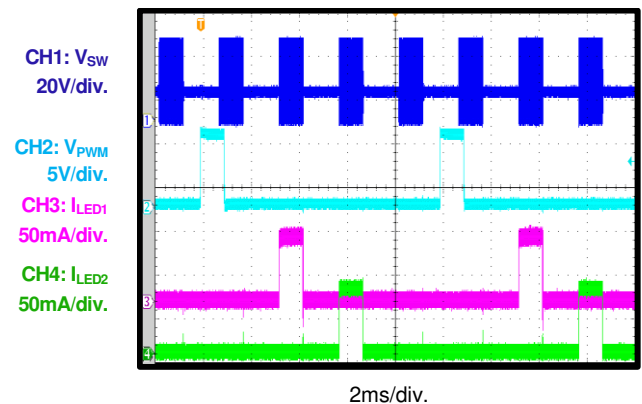
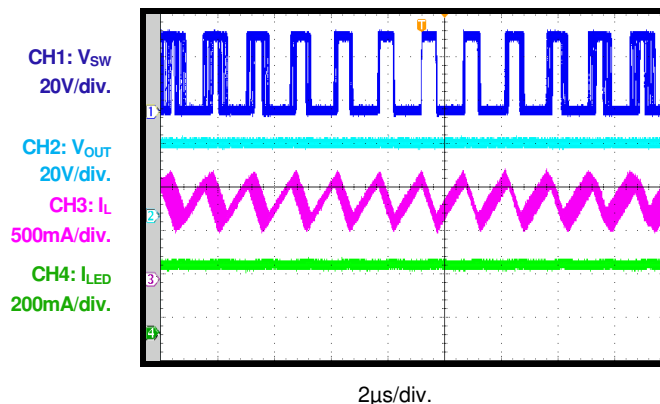
**PWM Dimming**
 $f_{PWM} = 200Hz$ , 0.01% duty cycle

**PWM Dimming**
 $f_{PWM} = 100Hz$ , 0.005% duty cycle

**Mix Dimming**
 $f_{PWM} = f_{(ILED)} = 200Hz$ ,  $D_{PWM} = 10\%$ 

**Mix Dimming**
 $f_{PWM} = 200Hz$ ,  $f_{(ILED)} = 23kHz$ ,  $D_{PWM} = 10\%$ 

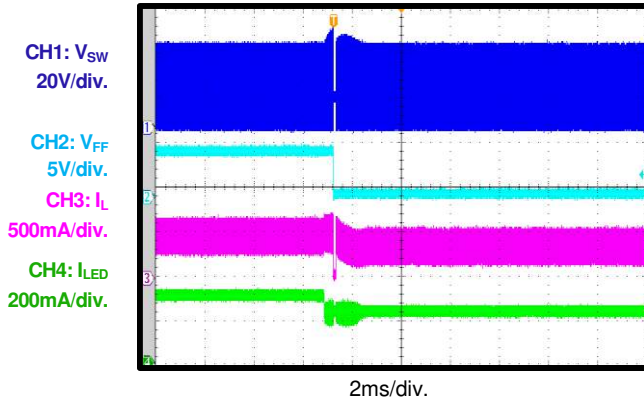
**Phase-Shift Function**
 $f_{PWM} = 200Hz$ , PWM dimming, 4 channels enabled

**Frequency Spread Spectrum**
 $f_{PWM} = 400Hz$ , 1/100 of center frequency

**TYPICAL PERFORMANCE CHARACTERISTICS (continued)**
 $V_{IN} = 12V$ ,  $L = 22\mu H$ , LED = 4P/12S,  $f_{SW} = 400kHz$ ,  $I_{SET} = 75mA$ ,  $T_A = 25^\circ C$ , unless otherwise noted.

**Open LED Protection**

Open 1 string during normal operation

**Short LED Protection**

Short 1 string during normal operation

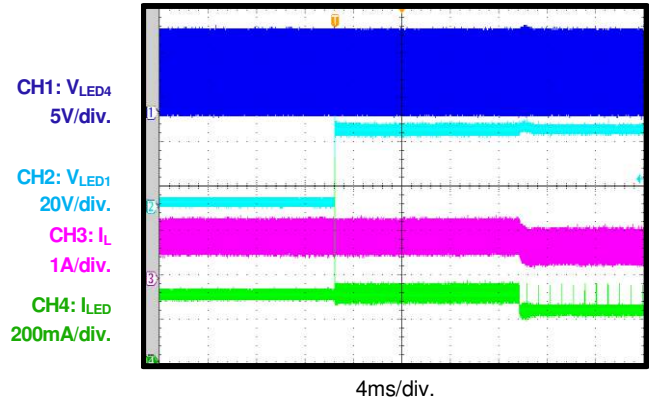
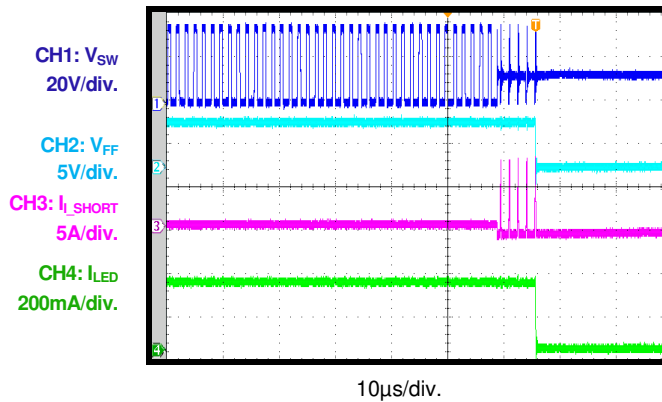
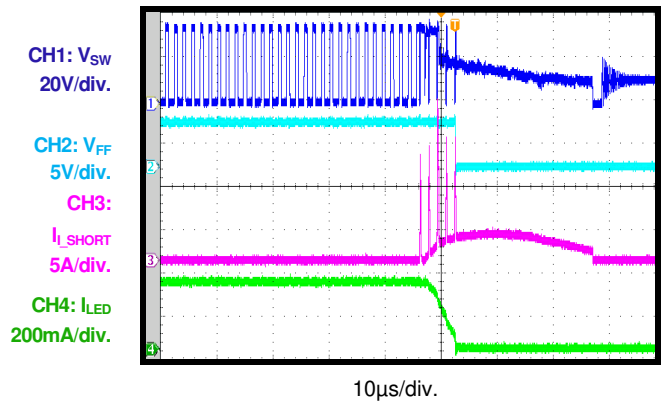
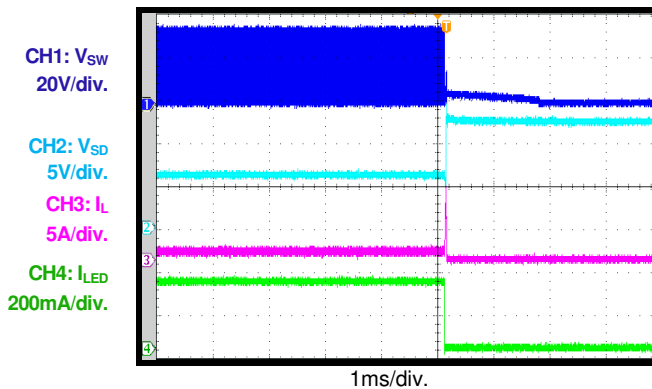
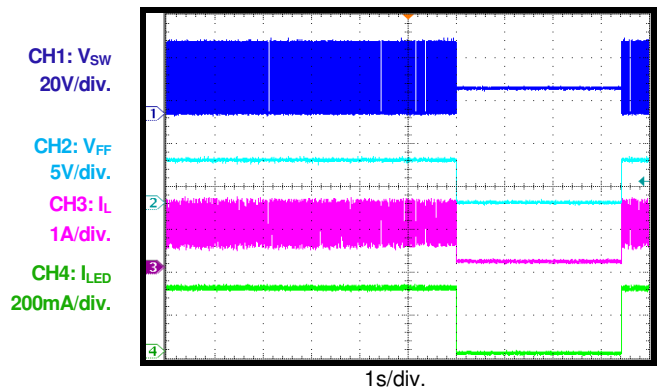
**Short Inductor Protection**

**Short Diode Protection**

**Short VOUT to GND Protection**

**Thermal Protection**

## FUNCTIONAL BLOCK DIAGRAM

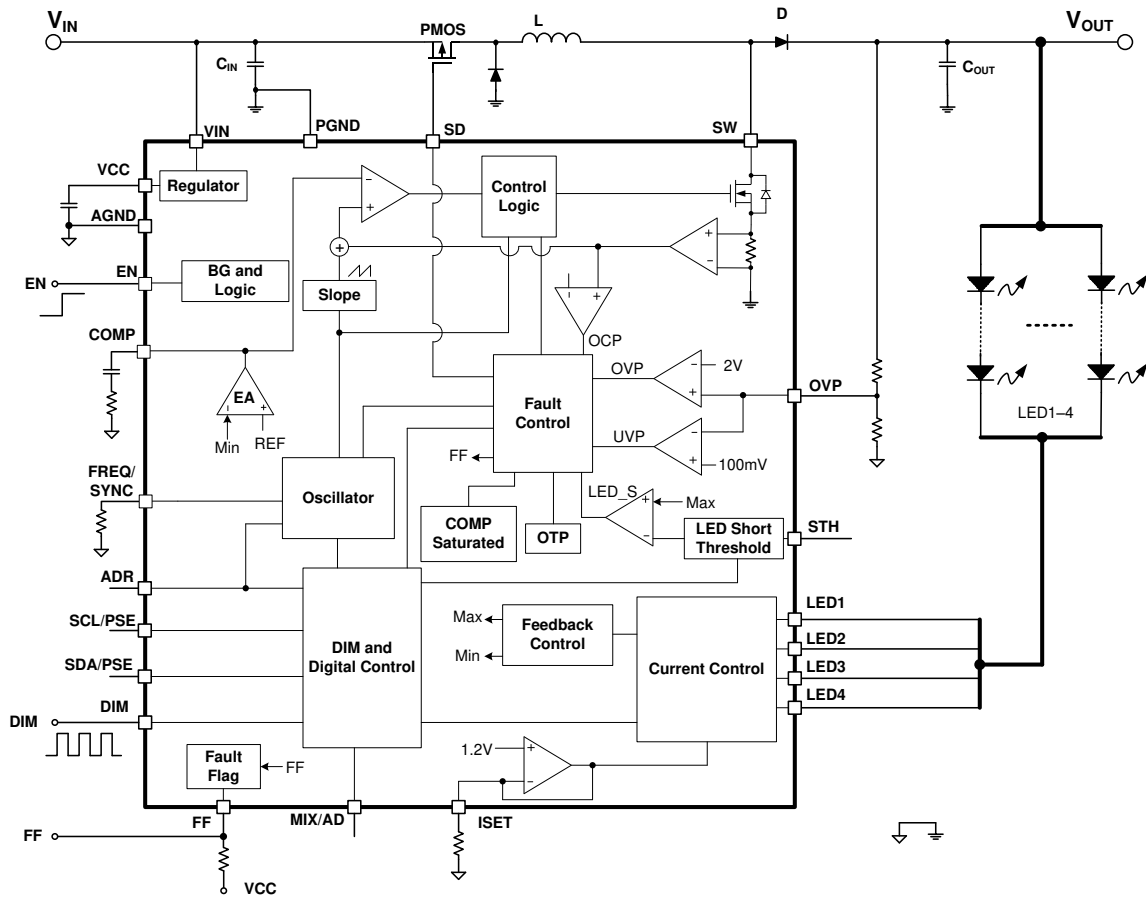

Figure 1: Functional Block Diagram

## OPERATION

The MPQ3364 is a configurable, fixed-frequency, peak current mode step-up converter with up to four channels of regulated current sources to drive an array of white LEDs.

### Internal 5V Regulator

The MPQ3364 includes an internal linear regulator (VCC). When  $V_{IN}$  exceeds 6V, this regulator outputs a 5V power supply to the internal MOSFET switch gate driver and the internal control circuitry. The VCC voltage drops to 0V when the chip shuts down. The chip remains disabled until VCC exceeds the under-voltage lockout (UVLO) threshold.

### System Start-Up

When enabled, the MPQ3364 checks the topology connection. The IC draws current from the SD pin to turn on the P-channel MOSFET if it is used (see Figure 1). After a 500 $\mu$ s delay, the IC monitors the OVP pin to see if the output is shorted to GND. If the OVP voltage is below 100mV, the IC is disabled, and it latches off. The MPQ3364 then continues to check other safety limits (e.g. LED open, over-voltage protection). If all protection tests pass, the IC starts boosting the step-up converter with an internal soft start.

The recommended start-up sequence is listed below:

1.  $V_{IN}$
2. EN
3. I<sup>2</sup>C (optional)
4. PWM dimming signal

### Step-Up Converter

The MPQ3364 employs peak current mode control to regulate the output power. At the beginning of each switching cycle, the internal clock turns on the internal N-channel MOSFET. In normal operation, the minimum turn-on time is about 100ns. A stabilizing ramp is added to the output of the current-sense amplifier to prevent sub-harmonic oscillations for duty cycles exceeding 50%. This result is fed into the PWM comparator. When the summed voltage reaches the output voltage of the error amplifier, the internal MOSFET turns off.

The output voltage of the internal error amplifier is an amplified signal of the difference between

the reference voltage and the feedback voltage. The converter automatically chooses the lowest active LEDx pin voltage to provide a sufficient output voltage to power all the LED arrays.

If the feedback voltage drops below the reference voltage, the output of the error amplifier increases. Then more current flows through the MOSFET, which increases the power delivered to the output. This forms a closed loop that regulates the output voltage.

During light-load operation (e.g. when  $V_{OUT}$  is almost equal to  $V_{IN}$ ), the converter runs in pulse-skip mode. In this mode, the MOSFET turns on for a minimum on time, then the converter discharges the power to the output for the remaining period. The external MOSFET remains off until the output voltage requires another boost.

### Dimming Control

The MPQ3364 provides analog, PWM, and mix dimming modes. The dimming mode can be set via the I<sup>2</sup>C, or by connecting a different resistor at MIX/AD. The MIX/AD voltage can be calculated with Equation (1):

$$V_{MIX/AD}(mV) = 18(\mu A) \times R_{MIX/AD}(k\Omega) \quad (1)$$

Where  $V_{MIX/AD}$  is the MIX/AD voltage, and  $R_{MIX/AD}$  is the resistor at MIX/AD.

### Mix Dimming Mode

There are two methods to set the MPQ3364 to work in mixture dimming mode, with either a 25% or 12.5% transfer point (selected through the internal register).

The first method is to connect a resistor to MIX/AD and set its voltage to a low level (<0.3V).

The second method is to float MIX/AD, and set the internal mode selection register (MODE1:0) to 00 through the I<sup>2</sup>C.

A PWM dimming signal is applied to DIM. When the dimming duty exceeds 25%, the device uses analog dimming, and the LED current amplitude follows the PWM duty.

When the dimming duty is below 25%, the device uses PWM dimming (see Figure 2). The LED current amplitude remains at 1/4 of the full-



scale current, and the output dimming duty is 4 times the duty of the input PWM signal.

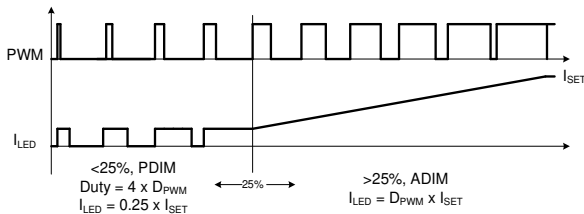

**Figure 2: Mix Dimming with 25% Transfer Point**

There are two options for the output dimming frequency when the device uses mix dimming: 200Hz (default), or 23kHz (no audible noise, but larger minimum dimming duty). The output dimming frequency does not change based on the input PWM dimming frequency. The output dimming frequency is selected with the mix dimming output frequency selection bit through the I<sup>2</sup>C. This function eliminates audible noise and improves the dimming performance when there is a small dimming ratio.

### Direct PWM Dimming

Connect a resistor to MIX/AD set its voltage to a middle level (0.5V to 0.8V), or float MIX/AD and set the internal mode selection register (MODE1:0) to 01 through the I<sup>2</sup>C.

When a PWM signal is applied to DIM, the amplitude of the LED current remains at the LED full-scale, and the LED current duty is the same as the input PWM signal duty. The LED current duty follows the PWM input duty, and the LED current frequency is the same as the PWM input.

### Analog Dimming Mode

Use a resistor to set MIX/AD to a high level (1V to 1.3V), or float MIX/AD and set the internal mode selection register (MODE1:0) to 10 through the I<sup>2</sup>C.

The PWM input signal is calculated by an internal counter. The amplitude of the LED current is equal to  $I_{SET} \times D_{DIM}$ , where  $I_{SET}$  is the full-scale LED current, and  $D_{DIM}$  is the duty of the input PWM signal. To improve analog dimming performance, a PWM signal between 100Hz and 20kHz is recommended.

To ensure good performance with a small dimming ratio, the minimum LEDx voltage rises up to 2V when the dimming duty is below 10%. Analog dimming supports a 200:1 dimming ratio.

### Deep Dimming Ratio for PWM Dimming

When the output dimming on time is shorter than 7 $\mu$ s, the output voltage is regulated to be 93% of the OVP voltage (see Figure 3).

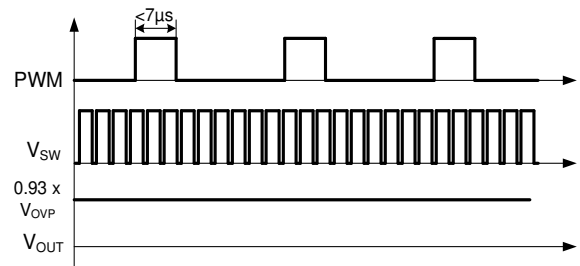

**Figure 3: Deep Dimming Ratio for PWM Dimming Unused LED Channel Setting**

If the LEDx pin of an unused channel is connected to GND, the MPQ3364 can automatically detect the unused LED string and remove it from the control loop during start-up. If only 3 strings are used, connect LED4 to GND.

The MPQ3364 can also disable the unused strings via the internal register (CH2:0). The register options are listed below:

- CH2:0 = 000/001/010: LED1~4 are in use
- CH2:0 = 011: LED1~3 are in use
- CH2:0 = 100: LED1~2 are in use
- CH2:0 = 101: LED1 is in use

### Phase Shift Function

To reduce inrush current and eliminate audible noise during PWM dimming, the MPQ3364 employs a phase shift function. Two methods can be used to enable the phase shift function.

The first method is to connect SCL/PSE and SDA/PSE together, and set them between 0.75V and 1V. The second method is to set the internal register's PSE bit to 1 through the I<sup>2</sup>C.

The LED channels' current source is phase shifted when the IC uses PWM dimming. The shifted phase depends on which LED channels are in use. The phase shift can be estimated with Equation (2):

$$\text{Phase}(\text{°}) = \frac{360}{n}(\text{°}) \quad (2)$$

Where n is the number of LED channels being used. If all four channels are in use, the shifted phase is 90°. LED1 directly follows the input PWM signal, and LED2 lags 90° behind (see Figure 4).

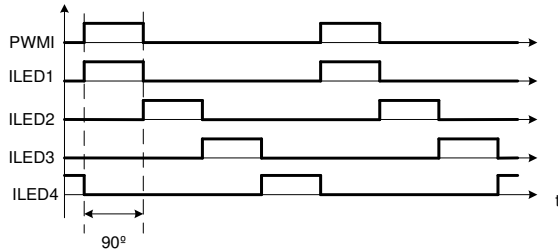

**Figure 4: Phase Shift with 4 Channels**

In phase shift operation, the channels must be disabled in descending order of channel number. For example, if three strings are employed in an application, then channel 4 is disabled.

It is not recommended to tie two channels to one LED string when the phase shift function is enabled.

### Frequency Spread Spectrum

The MPQ3364 uses switching frequency jitter to spread the switching frequency spectrum. This reduces the spectrum spike around the switching frequency and its harmonic frequencies.

The frequency jitter range is selected by the FSPR bit, which is described in greater detail below:

- When FSPR = 0 (default), the jitter frequency is 1/10 of the central frequency.
- When FSPR = 1, the jitter frequency is 1/16 of the central frequency.

The modulation frequency is selected by FSPMF1:0 bits, described in greater detail below:

- When FSPMF1:0 = 00, the modulation frequency is 1/100 of the switching frequency.
- When FSPMF1:0 = 01 (default), the modulation frequency is 1/150 of the switching frequency.
- When FSPMF1:0 = 10, the modulation frequency is 1/200 of the central frequency.

- When FSPMF1:0 = 11, the function is disabled.

### Protections

The MPQ3364 provides open LED protection, short LED protection, LEDx to GND short protection, over-current protection, VOUT to GND short protection, and thermal protection. If a protection is triggered, FF is pulled to GND, and the corresponding fault bit is set to 1. After the IC recovers from a protection, FF is pulled high after a 750µs delay.

#### Open LED Protection

Open string protection is achieved by detecting the voltage on the OVP pin and LEDx pins. If one string is open during normal operation, the respective LEDx voltage drops low to ground, and the IC keeps charging the output voltage until it reaches the over-voltage protection threshold.

If over-voltage protection has been triggered, the chip stops switching and marks off the fault string, which has an LEDx pin voltage below 100mV. The remaining LED strings force the output voltage back into normal regulation. The string with the largest voltage drop determines the output regulation value. Every 500µs, the string that was marked sends a 10µs pulse current to check whether the open fault has been removed. This means that open string protection is recoverable.

#### Short String Protection

The MPQ3364 monitors the LEDx voltages to determine whether a short string fault has occurred. If one or more strings are shorted, the shorted LEDx pins tolerate the high voltage stress. If an LEDx voltage exceeds the short protection threshold, an internal counter starts.

If the fault condition lasts for 7.7ms ( $D_{PWM} = 100\%$ ), the fault string is marked off. Once a string is marked off, it disconnects from the output voltage loop until the short is removed.

Two methods can set the short protection threshold. The first method is to connect a resistor on the STH pin. STH outputs an 18µA current source. The short protection threshold is 10 times the voltage on STH. The threshold ( $V_{STH}$ ) can be calculated with Equation (3):

$$V_{STH} (V) = 0.18 \times R_{STH} (k\Omega) \quad (3)$$



The second method is to set the internal register (TH\_S1:0) when STH is floating.

If the LEDx voltage on all used pins exceeds the threshold for 480ms ( $D_{PWM} = 100\%$ ), all strings are marked off. The IC remains on standby until the strings are released from the short condition. Enable or disable this function through SEN.

Every 500 $\mu$ s, the string that was marked off sends a 10 $\mu$ s pulse current to check if the short fault is removed. This means that short string protection is recoverable.

### **LEDx to GND Short Protection**

If LEDx is shorted to GND, the COMP voltage increases and saturates. If COMP is saturated for 40ms, a protection is triggered. FF pulls low, and SD pulls high to turn on the external P-channel MOSFET. Then the IC latches off.

### **VOUT to GND Short Protection**

If VOUT is shorted to GND, the output voltage decreases. If the voltage on the OVP pin reaches the under-voltage lockout (UVLO) threshold for 10 $\mu$ s, the protection is triggered. SD pulls high to turn off the external P-channel MOSFET. VOUT disconnects from VIN, and the IC latches off.

### **Cycle-by-Cycle Current Limit**

To prevent the external components from exceeding the current stress rating, the IC has cycle-by-cycle current limit protection. If the current exceeds the current limit value, the IC stops switching until the next clock cycle.

### **Latch-Off Current Limit Protection**

The device can be damaged by extreme conditions, such as an inductor or diode short to GND. To avoid this, the MPQ3364 provides latch-off current limit protection. If the current flowing through the internal MOSFET reaches 12A, and lasts for 5 switching cycles, current limit protection is triggered.

### **Thermal Protection**

To prevent the IC from operating at exceedingly high temperatures, the MPQ3364 implements thermal protection by detecting the silicon die temperature.

### **Over-Temperature LED Current Decrement**

If the die temperature exceeds 140°C, the MPQ3364 automatically reduces the LED current amplitude (see Figure 5).

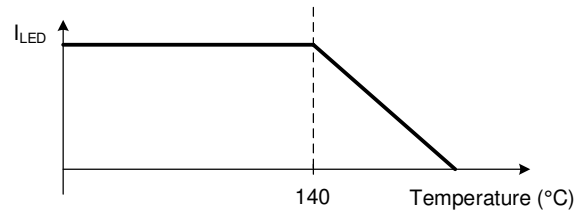

**Figure 5: I<sub>LED</sub> Decreases with Temperature**

This function is enabled by the over-temperature current decrement bit (OTID), described in greater detail below:

- When OTID = 0 (default), the over-temperature current decrement function is disabled.
- When OTID = 1, the over-temperature current decrement function is enabled.

### **Thermal Shutdown**

If the die temperature exceeds the upper threshold ( $T_{ST}$ ), the IC shuts down. When the temperature drops below the lower threshold, the IC recovers. The hysteresis value is about 20°C.

### **I<sup>2</sup>C Interface Register Description**

#### **I<sup>2</sup>C Chip Address**

The 7-bit MSB device address is 0x38~0x3A. This address can be selected through the ADR pin. When the ADR pin is floating, the IC address is 0x38. When  $ADR < 0.4V$ , the IC address is 0x3A. When ADR is between 0.4V and 1.4V, the IC address is 0x39. The ADR pin's pull-up current is 18 $\mu$ A.

After the start condition, the I<sup>2</sup>C-compatible master sends a 7-bit address followed by an eighth read (1) or write (0) bit.

The eighth bit indicates the register address to/from which the data will be written/read. Figure 6 shows an I<sup>2</sup>C-compatible device address.

0	1	1	1	0	X	X	R/W
---	---	---	---	---	---	---	-----

**Figure 6: I<sup>2</sup>C-Compatible Device Address**

## REGISTER MAP

If using the internal registers, float the corresponding pins.

Add	D7	D6	D5	D4	D3	D2	D1	D0
00H	OTID	MODE1	MODE0	MIXTP	MIXFR	FSPMF1	FSPMF0	FSPR
01H	PSEN	TH_S1	TH_S0	FSW1	FSW0	CH2	CH1	CH0
02H	SEN	DISABLE_IC	FT_LEDG	FT_OTP	FT_UVP	FT_OCP	FT_LEDS	FT_LEDO
03H	RESERVED	RESERVED	ID5	ID4	ID3	ID2	ID1	ID0

### Function Settings (Register 1)

Addr: 0x00				
Bits	Bit Name	Access	Default	Description
7	OTID	R/W	0	Enables the over-temperature LED current decrement function. 0: Disabled 1: Enabled
6:5	MODE	R/W	00	Selects the dimming mode. Float the MIX/AD pin if this register is used. 00: Mix dimming 01: PWM dimming 10: Analog dimming 11: Reserved
4	MIXTP	R/W	0	Selects the mix dimming transfer point. 0: 25% transfer point 1: 12.5% transfer point
3	MIXFR	R/W	0	Selects the mix dimming output frequency. 0: 200Hz 1: 23kHz
2:1	FSPMF1:0	R/W	01	Selects the frequency spread spectrum modulation frequency. 00: 1/100 of the central frequency 01: 1/150 of the central frequency 10: 1/200 of the central frequency 11: Disable the frequency spread spectrum function
0	FSPR	R/W	0	Selects the frequency spread spectrum jitter range. 0: 1/10 of the central frequency 1: 1/16 of the central frequency

### Function Settings (Register 2)

Addr: 0x01				
Bits	Bit Name	Access	Default	Description
7	PSE	R/W	0	Enables the phase shift function. 0: Phase shift disabled 1: Phase shift enabled

6:5	TH_S1:0	R/W	01	Sets the LED short protection threshold. 00: 2.5V 01: 5V 10: 7.5V 11: 10V
4:3	FSW1:0	R/W	01	Sets the switching frequency. Float the FREQ/SYNC pin if this register is used. 00: 200kHz 01: 400kHz 10: 1MHz 11: 2.2MHz
2:0	CH2:0	R/W	000	Channel selection bit. 000/001/010: LED1–4 are in use 011: LED1–3 are in use 100: LED1–2 are in use 101: LED1 is in use 110/111: Reserved

### Fault Register

Addr: 0x02				
Bits	Bit Name	Access	Default	Description
7	SEN	R/W	0	Enables all LED short protections. 0: Disabled 1: Enabled
6	DISABLE_IC	R/W	0	Disables the IC. 0: The IC is enabled 1: The IC is disabled
5	FT_LEDG	R	0	Indicates if an LEDx short to GND fault has occurred. If an LEDx short fault occurs, the fault bit is set to 1 until a readback or power reset occurs. Once this bit is read, the fault status cannot latch off until it is set to 0. 0: No LEDx short fault has occurred 1: An LEDx short fault has occurred
4	FT_OTP	R	0	Indicates if over-temperature protection (OTP) has occurred. If an OT fault occurs, the fault bit is set to 1 until a readback or power reset occurs. Once this bit is read, the fault status cannot latch off until it is set to 0. 0: No OT fault has occurred 1: An OT fault has occurred
3	FT_UVP	R	0	Indicates if output under-voltage protection (UVP) has occurred. If a UV fault occurs, the fault bit is set to 1 until a readback or power reset occurs. Once this bit is read, the fault status cannot latch off until it is set to 0. 0: No UV fault has occurred 1: A UV fault has occurred
2	FT_OCP	R	0	Indicates if over-current protection (OCP) has occurred. If an OC fault occurs, the fault bit is set to 1 until a readback or power reset occurs. Once this bit is read, the fault status cannot latch off until it is set to 0. 0: No OC fault has occurred 1: An OC fault has occurred

1	FT_LEDS	R	0	<p>Indicates if an LED current source short fault has occurred. If a current source short fault occurs, the fault bit is set to 1 until a readback or power reset occurs. Once this bit is read, the fault status cannot latch off until it is set to 0.</p> <p>0: No LED current source short fault has occurred 1: An LED current source short fault has occurred</p>
0	FT_LED0	R	0	<p>Indicates if an LED current source open fault has occurred. If an open fault occurs, the fault bit is set to 1 until a readback or power reset occurs. Once this bit is read, the fault status cannot latch off until it is set to 0.</p> <p>0: No LED current source open fault has occurred 1: An LED current source open fault has occurred</p>

**ID Register**

Addr: 0x03				
Bits	Bit Name	Access	Default	Description
7:6	RESERVED	-	-	Reserved.
5:0	ID7:0	R	01100111	Device ID bits.

## APPLICATION INFORMATION

### LED Current Setting

The LED current amplitude is set by an external resistor connected from ISET to GND. The LED current amplitude can be calculated with Equation (4):

$$I_{LED}(\text{mA}) = \frac{1245}{R_{ISET}(\text{k}\Omega)} \quad (4)$$

For example, if  $R_{ISET} = 24.9\text{k}\Omega$ , the LED current is 50mA.

### Switching Frequency

The switching frequency can be configured by a resistor, I<sup>2</sup>C interface, or external clock.

Configure the frequency by connecting an external resistor to FREQ/SYNC. The switching frequency can be estimated with Equation (5):

$$f_{sw}(\text{kHz}) = \frac{22000}{R_{OSC}(\text{k}\Omega)} \quad (5)$$

For example, if  $R_{OSC} = 44.2\text{k}\Omega$ , the switching frequency is set to 500kHz.

Synchronize the switching frequency via an external clock to improve EMI, efficiency, and thermal performance.

If setting the switching frequency via the I<sup>2</sup>C interface, float the FREQ/SYNC pin. The FSW1:0 bit has the following options:

- 00: 200kHz
- 01: 400kHz
- 10: 1MHz
- 11: 2.2MHz

### Selecting the Input Capacitor

The input capacitor reduces the surge current drawn from the input supply, as well as the switching noise from the device. The input capacitor impedance at the switching frequency should be less than the input source impedance. This prevents the high-frequency switching current from passing through to the input. Use ceramic capacitors with X5R or X7R dielectrics for their low ESR and small temperature

coefficients. For most applications, a 10 $\mu$ F ceramic capacitor is sufficient.

### Selecting the Inductor

The MPQ3364 requires an inductor to supply a higher output voltage while being driven by the input voltage. A larger-value inductor results in less ripple current, lower peak inductor current, and less stress on the internal N-channel MOSFET. However, a larger-value inductor has a larger physical size, higher series resistance, and lower saturation current.

Choose an inductor that does not saturate under the worst-case load conditions. Select the minimum inductor value to ensure that the boost converter works in continuous conduction mode (CCM) with high efficiency and excellent EMI performance.

Calculate the required inductance value with Equation (6):

$$L \geq \frac{\eta \times V_{OUT} \times D \times (1-D)^2}{2 \times f_{sw} \times I_{LOAD}} \quad (6)$$

Where  $V_{OUT}$  is the output voltage,  $f_{sw}$  is the switching frequency,  $I_{LOAD}$  is the LED load current,  $\eta$  is the efficiency, and  $D$  can be estimated with Equation (7):

$$D = 1 - \frac{V_{IN}}{V_{OUT}} \quad (7)$$

Where  $V_{IN}$  is the input voltage.

For a given inductor value, the inductor DC current rating should be at least 40% higher than the maximum input peak inductor current for most applications. The inductor's DC resistance should be as small as possible for higher efficiency.

### Selecting the Output Capacitor

The output capacitor keeps the output voltage ripple small and ensures feedback loop stability. The output capacitor impedance must be low at the switching frequency. Ceramic capacitors with X7R dielectrics are recommended for their low-ESR characteristics. For most applications, a 10 $\mu$ F ceramic capacitor is sufficient.

### PCB Layout Guidelines

Careful attention must be given to the PCB layout and component placement. Efficient placement of the high-frequency switching path is critical to prevent noise and electromagnetic interference. For the best results, refer to Figure 7 and follow the guidelines below:

1. The IC's exposed must be internally connected to the AGND pin, and all logic signals must be referred to AGND.
2. Externally connect PGND to AGND. Route PGND away from the logic signals.
3. Keep the loop between the SW to PGND pins, output diode (D1), and capacitor (C1, C2) as short as possible due to the high-frequency pulse current.

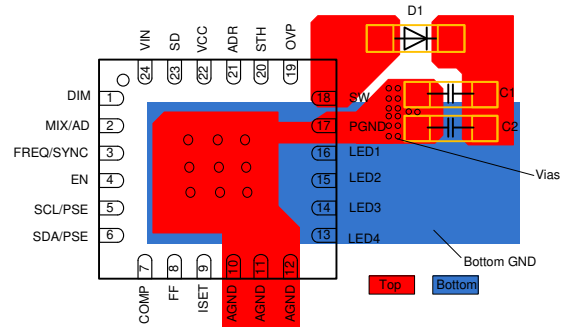

**Figure 7: Recommended PCB Layout**

## TYPICAL APPLICATION CIRCUITS

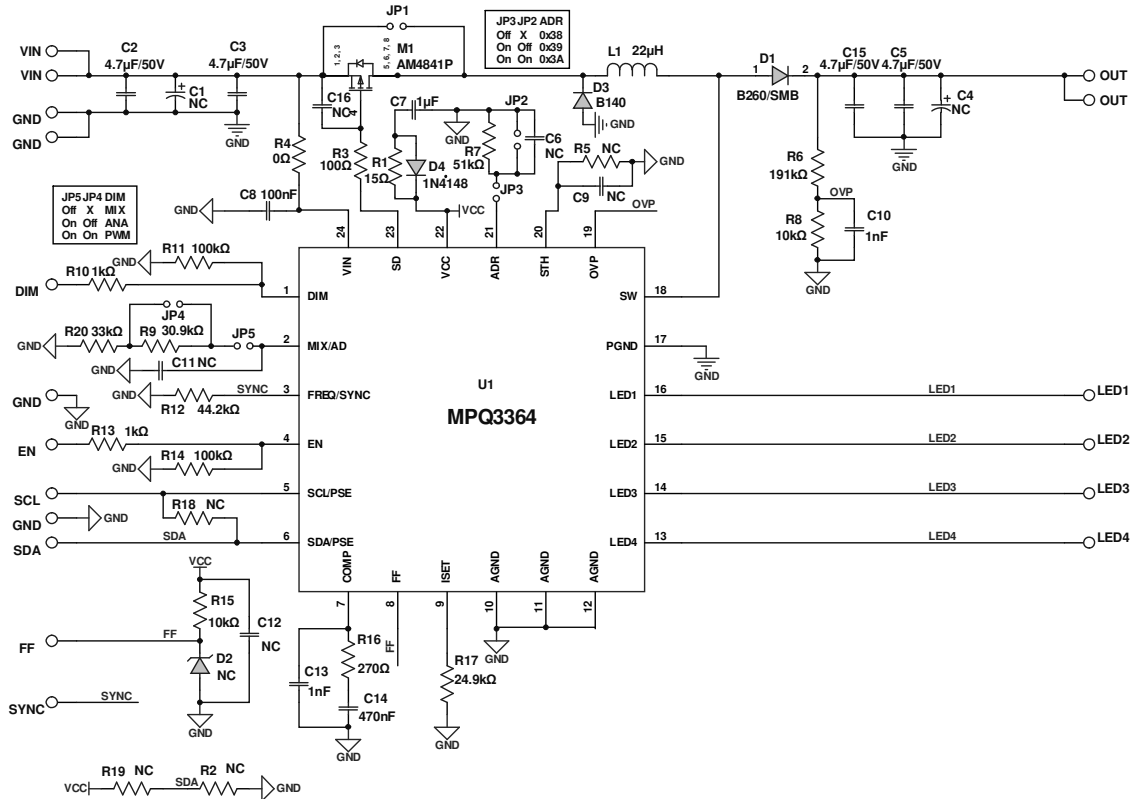

Figure 8: Typical Boost Application Circuit

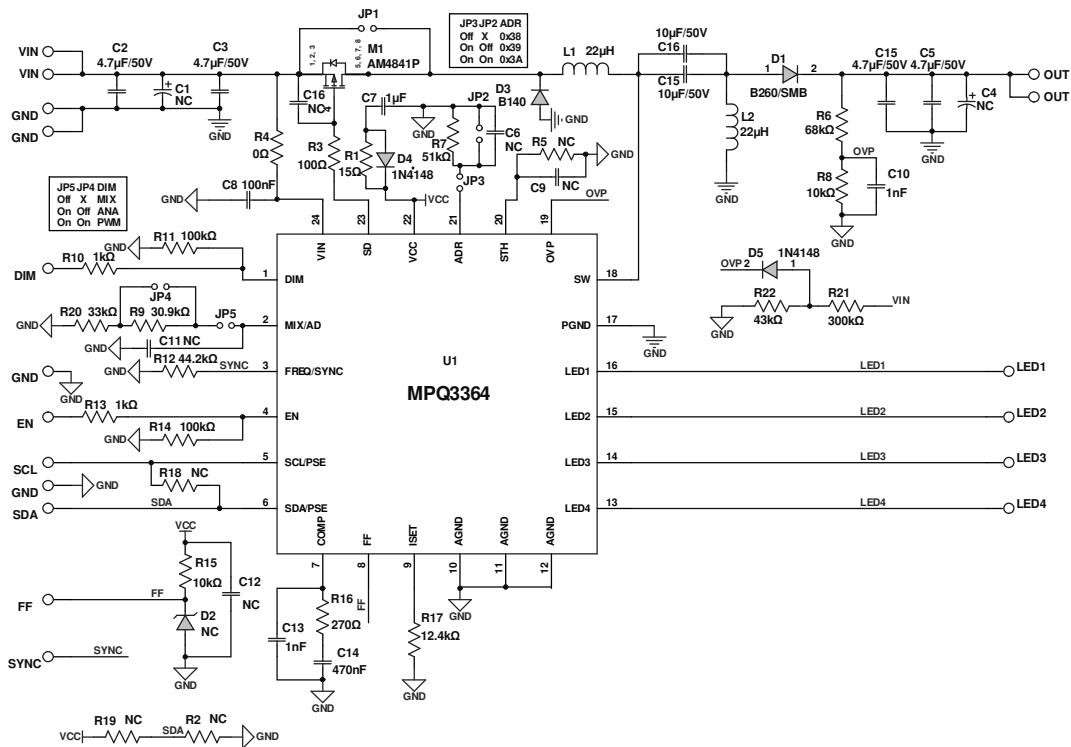
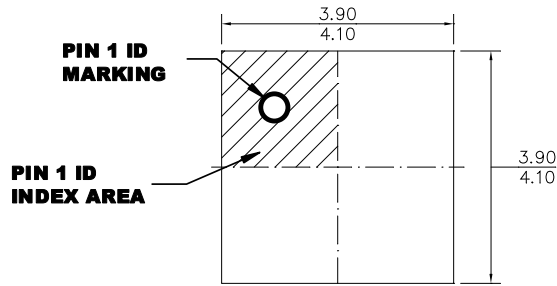

Figure 9: Typical SEPIC Application Circuit

# PACKAGE INFORMATION

## QFN-24 (4mmx4mm)



**TOP VIEW**

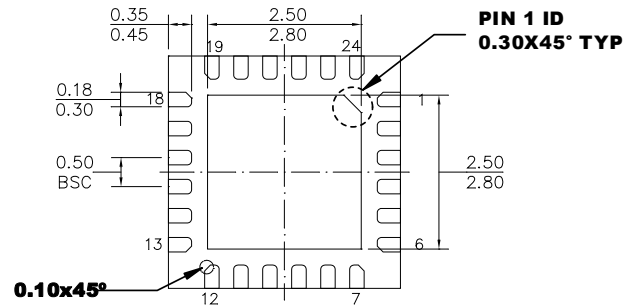

**BOTTOM VIEW**

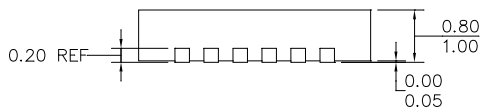

**SIDE VIEW**

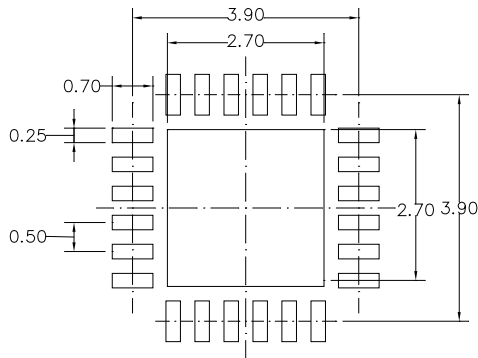

**RECOMMENDED LAND PATTERN**

**NOTE:**

- 1) ALL DIMENSIONS ARE IN MILLIMETERS.
- 2) EXPOSED PADDLE SIZE DOES NOT INCLUDE MOLD FLASH.
- 3) LEAD COPLANARITY SHALL BE 0.08 MILLIMETERS MAX.
- 4) JEDEC REFERENCE IS MO-220
- 5) DRAWING IS NOT TO SCALE.



# PACKAGE INFORMATION

## QFN-24 (4mmx4mm) WF

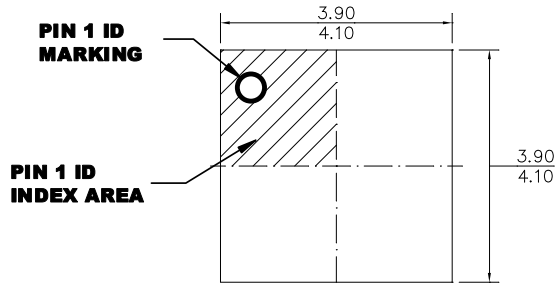

**TOP VIEW**

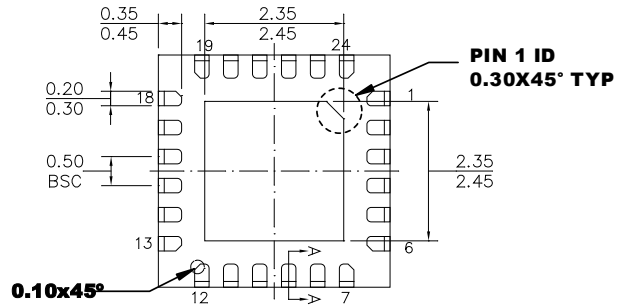

**BOTTOM VIEW**

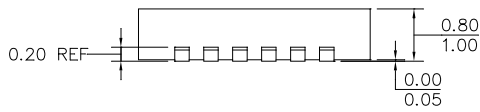

**SIDE VIEW**

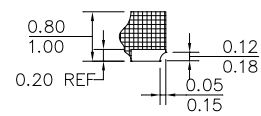

**SECTION A-A**

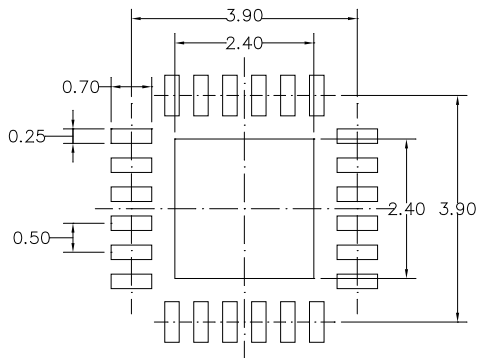

**RECOMMENDED LAND PATTERN**

**NOTE:**

- 1) THE LEAD SIDE IS WETTABLE.
- 2) ALL DIMENSIONS ARE IN MILLIMETERS.
- 3) LEAD COPLANARITY SHALL BE 0.08 MILLIMETERS MAX.
- 4) JEDEC REFERENCE IS MO-220.
- 5) DRAWING IS NOT TO SCALE.

## CARRIER INFORMATION

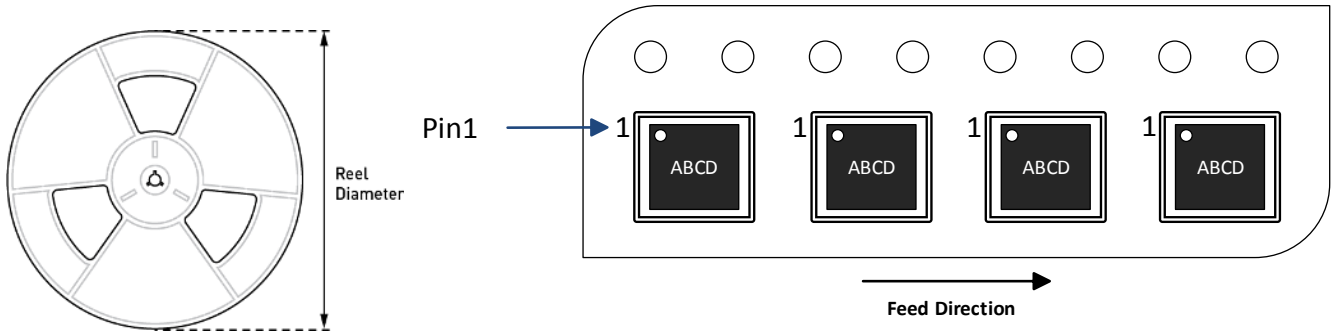

Part Number	Package Description	Quantity/ Reel	Quantity/ Tray	Quantity/ Tube	Reel Diameter	Carrier Tape Width	Carrier Tape Pitch
MPQ3364GR-AEC1-Z	QFN-24 (4mmx4mm)	5000	N/A	N/A	13in	12mm	8mm
MPQ3364GRE-AEC1-Z	QFN-24 (4mmx4mm) WF	5000	N/A	N/A	13in	12mm	8mm

## REVISION HISTORY

Revision #	Revision Date	Description	Pages Updated
1.0	3/3/2021	Initial Release	-
1.1	7/7/2021	Update STH voltage calculating equation; Update “FSPMF1:0 = 01 (default)”, “OTID = 0 (default)”.	16–17
		Grammar and formatting updates	All

**Notice:** The information in this document is subject to change without notice. Users should warrant and guarantee that third-party Intellectual Property rights are not infringed upon when integrating MPS products into any application. MPS will not assume any legal responsibility for any said applications.