

View without cover

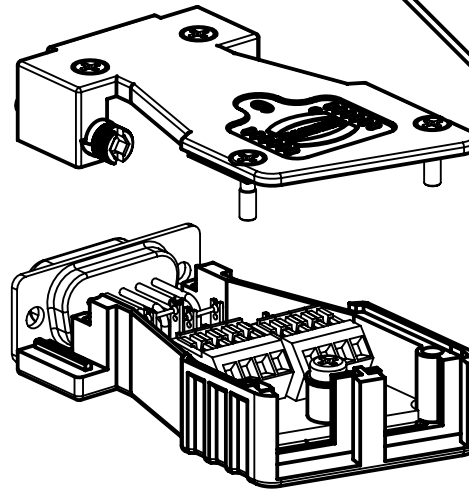

D-Sub 9 poles

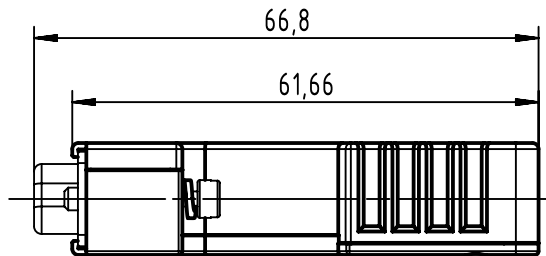
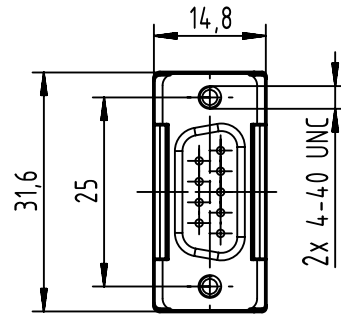
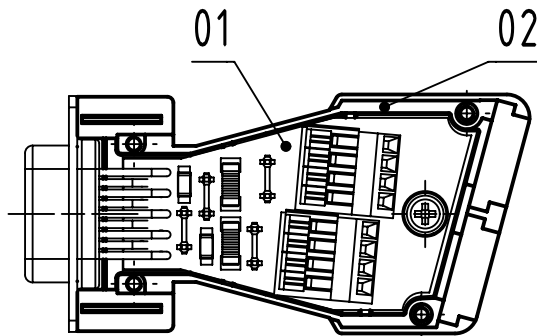
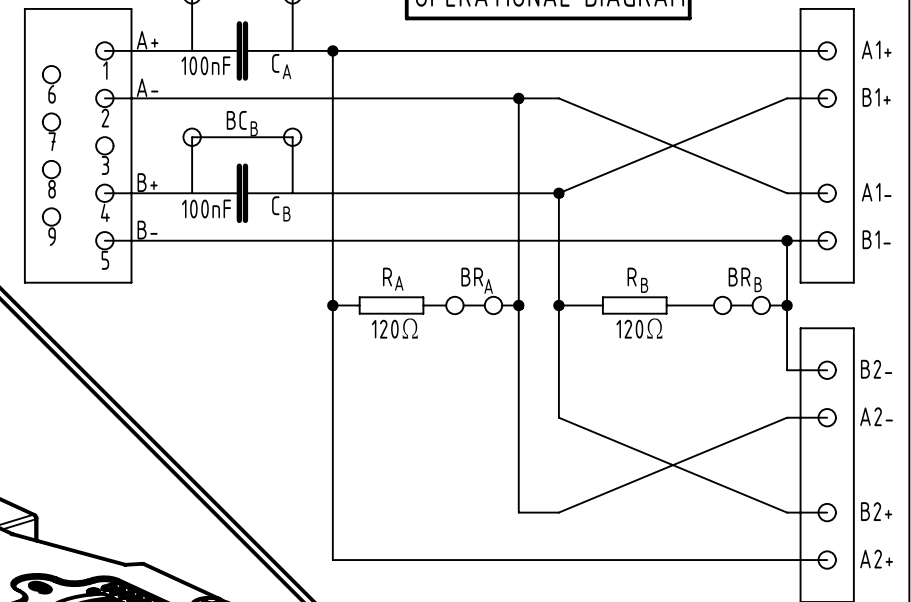

OPERATIONAL DIAGRAM

in set inclusive :

number	description
2	crimp flange 7,0-8,0
2	crimp ferrule 11,0-12,0
1	blanking piece 9-37P
1	label line A, B

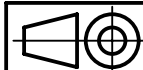

All Dimensions in mm
Original Size DIN A4

Scale
1:1

Free size tol.

Ref.

Sub.



All rights reserved

Department EL PD

Created by
ZHUANGJ

Inspected by
LUOK

Standardisation
ROEBEN

Date
2021-08-04

State
Final Release

HARTING

D-32339 Espelkamp

Title

InduCom 9 MVB/WTB male 4-40UNC

Doc-Key / ECM-Nr.
100073192/UGD/044/B
500000200533

Type
TB

Number

66630095032

Rev.
B

Page
1/1

6663 009 5032 777	PL1	Small batch
6663 009 5032	PL1	Standard batch
Part number	Performance level	Remark