

PART NUMBER	REV	FIRST USED
680820-1	B	122500-1
680820-2	B	565435-5
680820-3	B	354500-1

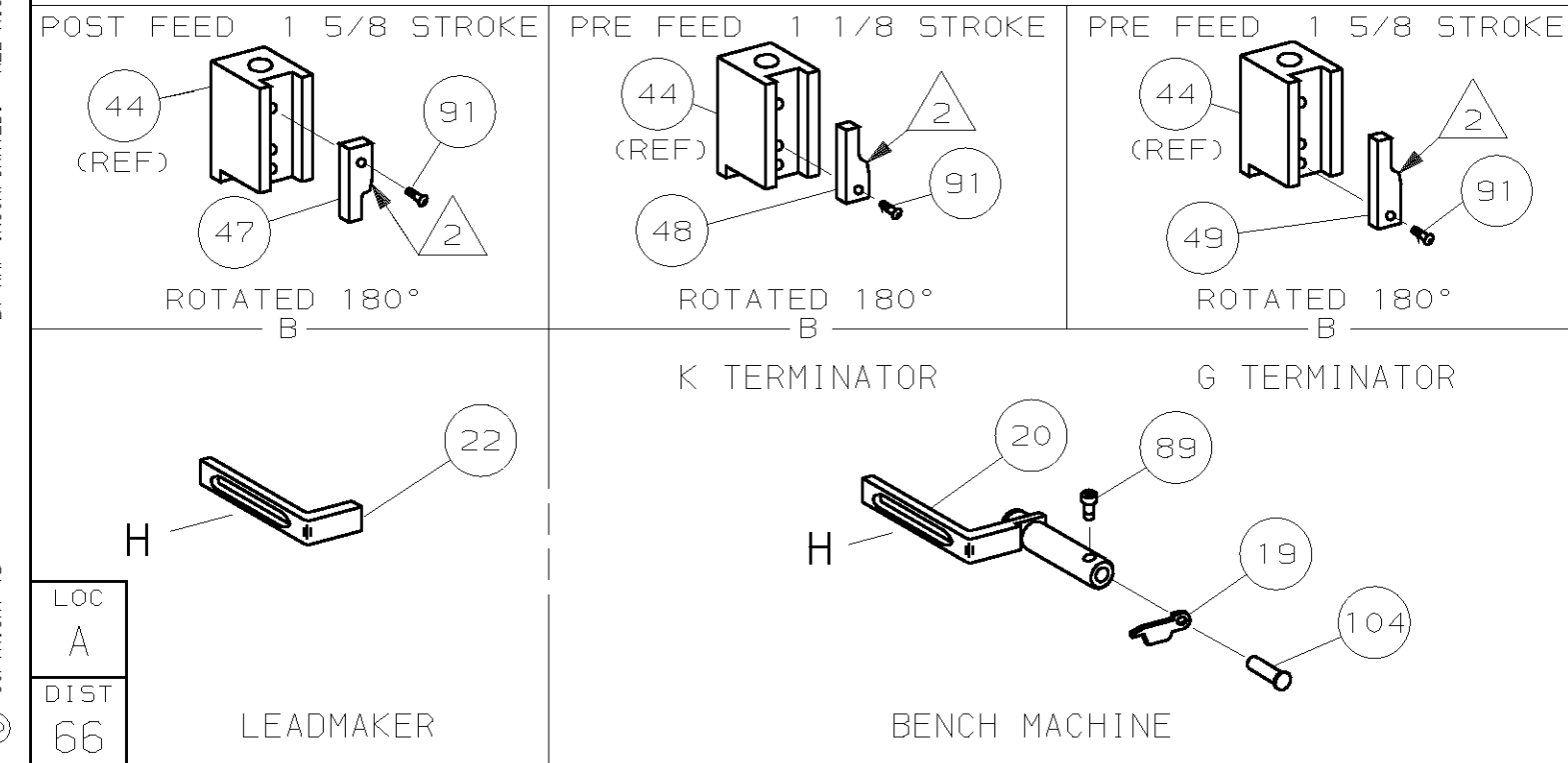
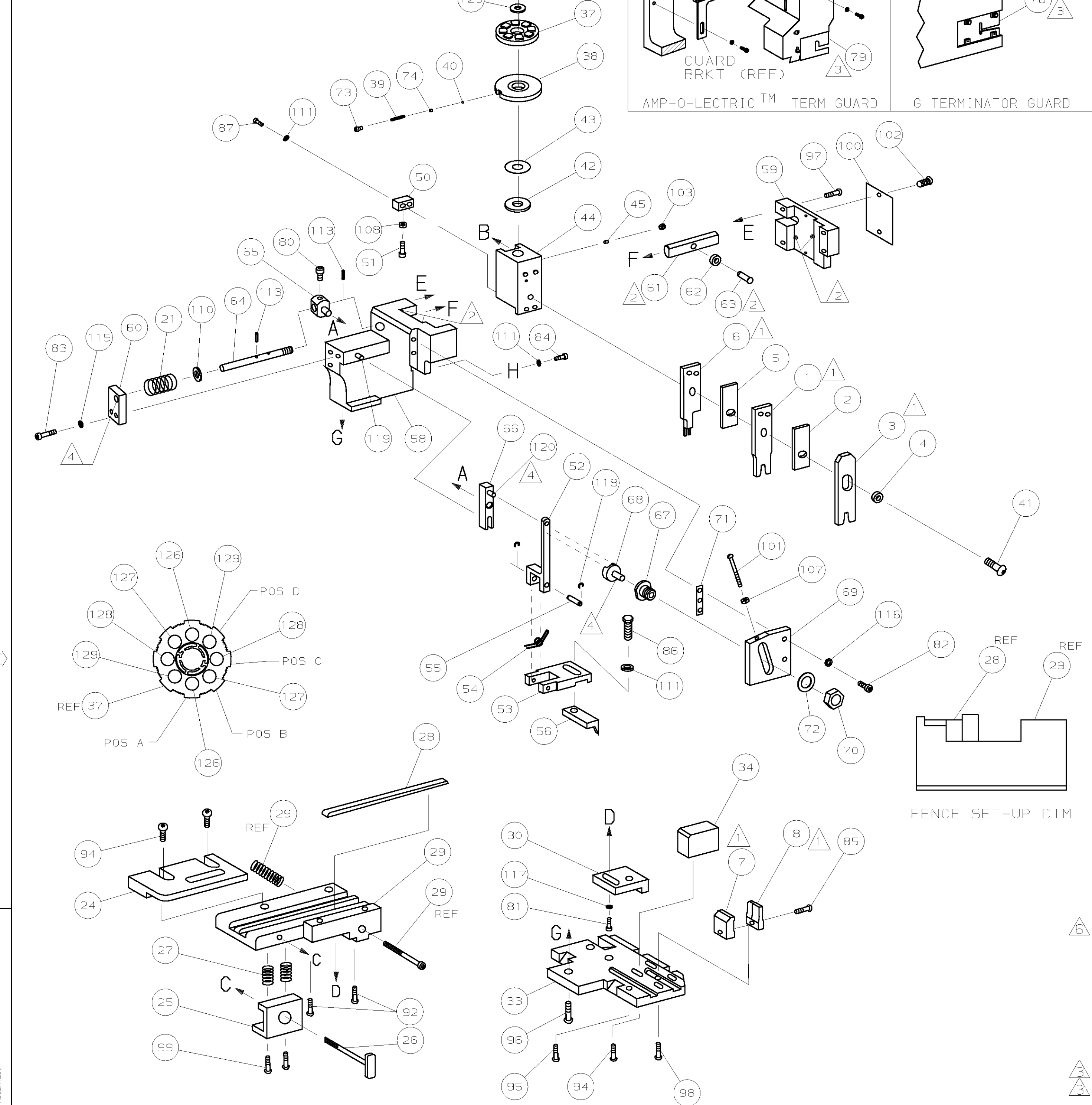

- 1 RECOMMENDED SPARE PARTS.
- 2 GREASE LIGHTLY.
- 3 GUARD MUST BE IN PLACE WHEN OPERATING APPLICATOR IN A BENCH MACHINE.
- 4 LUBRICATE DAILY USING NO. 20 MACHINE OIL.
- 5. ITEMS WITH QTY OF REF SPECIFIED (EXCEPT ITEMS 78 AND 79) ARE USED ON ITEM 46.
- 6 CUT TO LENGTH AT ASSY

TERMINAL NAME: TERMINAL CONTACT FOR T-5 WEDGE BASE LAMPS			
PAD LTR	CRIMP HEIGHT	WIRE SIZE	
A	.062 ±.002 [1.57 ±0.05mm]	16	
B	NOT	USED	
C	NOT	USED	
D	NOT	USED	
CRIMP	SIZE	TYPE	RANGE
WIRE	.080 [2.03mm]	F	16
INSUL	.118 [3.00mm]	F	.062 MAX

WIRE STRIP LENGTH	TERM APPL SPEC	FEED	APPL INSTRUCTION	SET UP GAGE	LAYOUT
.155-.203	NONE	.492	408-8040	458637-1	L2231

QTY	REV	DESCRIPTION	ITEM NO
1	1	1	129
1	1	1	128
1	1	1	127
2	2	2	126
1	1	1	125
1	1	1	124
1	1	1	123
1	1	1	122
1	1	1	121
1	1	1	120
1	1	1	119
1	1	1	118
1	1	1	117
1	1	1	116
1	1	1	115
1	1	1	114
1	1	1	113
4	4	4	112
1	1	1	111
1	1	1	110
1	1	1	109
1	1	1	108
1	1	1	107
1	1	1	106
1	1	1	105
1	1	1	104
1	1	1	103
2	2	2	102
1	1	1	101
1	1	1	100
2	2	2	99
1	1	1	98
1	1	1	97
1	1	1	96
4	4	4	95
1	1	1	94
2	2	2	93
1	1	1	92
1	1	1	91
1	1	1	90
1	1	1	89
2	2	2	88
1	1	1	87
1	1	1	86
1	1	1	85
1	1	1	84
1	1	1	83
1	1	1	82
1	1	1	81
1	1	1	80
-	1	1	79
REF	-	-	78
REF	-	-	77
REF	-	-	76
REF	-	-	75
1	1	1	74
1	1	1	73
1	1	1	72
1	1	1	71
-	3	-	70
-	2	-	69
-	1	-	68
-	1	-	67
-	1	-	66
-	1	-	65
-	1	-	64
-	1	-	63
-	1	-	62
-	1	-	61
-	1	-	60
-	1	-	59
-	1	-	58
-	1	-	57
-	1	-	56
-	1	-	55
-	1	-	54
-	1	-	53
-	1	-	52
-	1	-	51
-	1	-	50
-	1	-	49
-	1	-	48
-	1	-	47
-	1	-	46
-	1	-	45
-	1	-	44
-	1	-	43
-	1	-	42
-	1	-	41
-	1	-	40
-	1	-	39
-	1	-	38
-	1	-	37
-	1	-	36
-	1	-	35
-	1	-	34
-	1	-	33
-	1	-	32
-	1	-	31
-	1	-	30
-	1	-	29
-	1	-	28
-	1	-	27
-	1	-	26
-	1	-	25
-	1	-	24
-	1	-	23
-	1	-	22
-	1	-	21
-	1	-	20
-	1	-	19
-	1	-	18
-	1	-	17
-	1	-	16
-	1	-	15
-	1	-	14
-	1	-	13
-	1	-	12
-	1	-	11
-	1	-	10
-	1	-	9
-	1	-	8
-	1	-	7
-	1	-	6
-	1	-	5
-	1	-	4
-	1	-	3
-	1	-	2
-	1	-	1

QTY	REV	DESCRIPTION	ITEM NO
-	1	1	70
-	1	1	69
-	1	1	68
-	1	1	67
-	1	1	66
-	1	1	65
-	1	1	64
-	1	1	63
-	1	1	62
-	1	1	61
-	1	1	60
-	1	1	59
-	1	1	58
-	1	1	57
-	1	1	56
-	1	1	55
-	1	1	54
-	1	1	53
-	1	1	52
-	1	1	51
-	1	1	50
-	1	1	49
-	1	1	48
-	1	1	47
-	1	1	46
-	1	1	45
-	1	1	44
-	1	1	43
-	1	1	42
-	1	1	41
-	1	1	40
-	1	1	39
-	1	1	38
-	1	1	37
-	1	1	36
-	1	1	35
-	1	1	34
-	1	1	33
-	1	1	32
-	1	1	31
-	1	1	30
-	1	1	29
-	1	1	28
-	1	1	27
-	1	1	26
-	1	1	25
-	1	1	24
-	1	1	23
-	1	1	22
-	1	1	21
-	1	1	20
-	1	1	19
-	1	1	18
-	1	1	17
-	1	1	16
-	1	1	15
-	1	1	14
-	1	1	13
-	1	1	12
-	1	1	11
-	1	1	10
-	1	1	9
-	1	1	8
-	1	1	7
-	1	1	6
-	1	1	5
-	1	1	4
-	1	1	3
-	1	1	2
-	1	1	1

QTY	REV	DESCRIPTION	ITEM NO
-	1	1	70
-	1	1	69
-	1	1	68
-	1	1	67
-	1	1	66
-	1	1	65
-	1	1	64
-	1	1	63
-	1	1	62
-	1	1	61
-	1	1	60
-	1	1	59
-	1	1	58
-	1	1	57
-	1	1	56
-	1	1	55
-	1	1	54
-	1	1	53
-	1	1	52
-	1	1	51
-	1	1	50
-	1	1	49
-	1	1	48
-	1	1	47
-	1	1	46
-	1	1	45
-	1	1	44
-	1	1	43
-	1	1	42
-	1	1	41
-	1	1	40
-	1	1	39
-	1	1	38
-	1	1	37
-	1	1	36
-	1	1	35
-	1	1	34
-	1	1	33
-	1	1	32
-	1	1	31
-	1	1	30
-	1	1	29
-	1	1	28
-	1	1	27
-	1	1	26
-	1	1	25
-	1	1	24
-	1	1	23
-	1	1	22
-	1	1	21
-	1	1	20
-	1	1	19
-	1	1	18
-	1	1	17
-	1	1	16
-	1	1	15
-	1	1	14
-	1	1	13
-	1	1	12
-	1	1	11
-	1	1	10
-	1	1	9
-	1	1	8
-	1	1	7
-	1	1	6
-	1	1	5
-	1	1	4
-	1	1	3
-	1	1	2
-	1	1	1