

CXPI Transceiver for Automotive

BD41000AFJ-C

General Description

BD41000AFJ-C is a transceiver for the CXPI (Clock Extension Peripheral Interface) communication. Switching between Master/Slave Mode can be done using external pin (MS pin). Low power consumption during standby (non-communication) using Power Saving function. Arbitration function stops the data output upon detection of BUS data collision. Also Fail-safe function stops outputs upon detection of under voltage or temperature abnormality.

Key Specifications

- Power Supply Voltage : +7V to +18V
- Absolute Maximum Rating of BAT : -0.3V to +40V
- Absolute Maximum Rating of BUS : -27V to +40V
- Power OFF Mode Current : 3 μ A (Typ)
- Operating Temperature Range : -40°C to +125°C

Package
SOP-J8

W(Typ) x D(Typ) x H(Max)
4.90mm x 6.00mm x 1.65mm

Features

- AEC-Q100 Qualified (Note1)
- CXPI standards Qualified
- Transmission speed range from 5kbps to 20kbps
- Master/Slave switching function
- Microcontroller interface corresponds to 3.3V/5.0V
- Built-in terminator (30k Ω)
- Power saving function
- Data arbitration function
- Built-in Under Voltage Lockout (UVLO) function
- Built-in Thermal Shutdown (TSD) function
- Low EME(Electromagnetic Emission)
- High EMI(Electromagnetic Immunity)
- High ESD(Electrostatic Discharge) robustness (Note1: Grade 1)

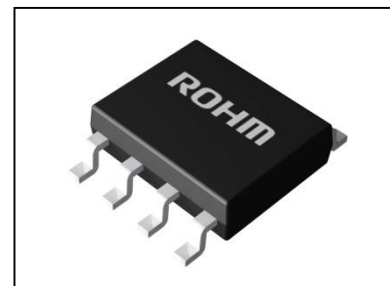

SOP-J8

Applications

- Automotive networks

Typical Application Circuit

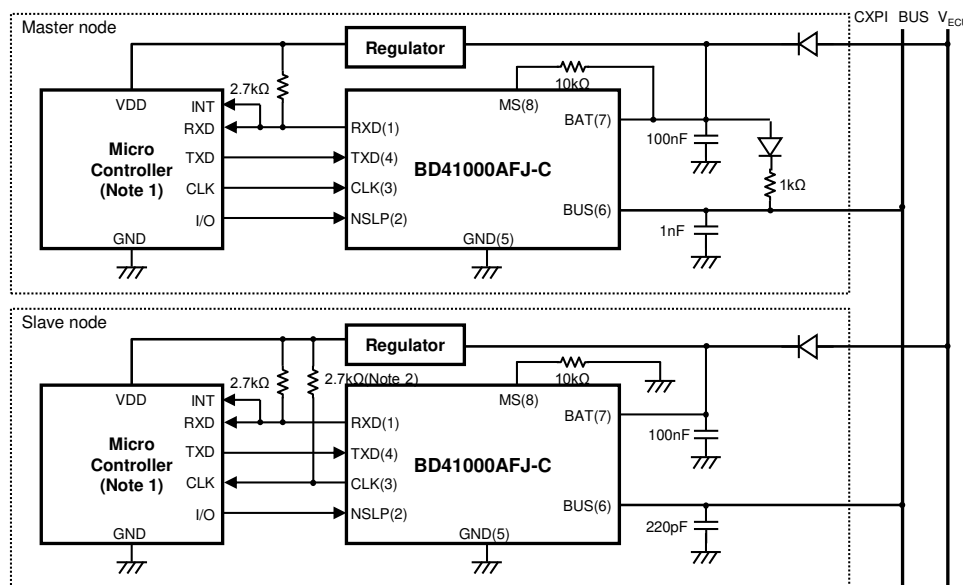

Note 1 INT: Interrupt, RXD: UART RXD, TXD: UART TXD, CLK: Clock, I/O: General Purpose I/O
Note 2 While using slave, It is no problem that CLK is opened in the case of non-using CLK output.

Figure 1. Typical Application Circuit

Consider the actual application design confirming the following linked document before applying this product.

- [Application Note](#)

○Product structure : Silicon monolithic integrated circuit ○This product has no designed protection against radioactive rays

Pin Configuration

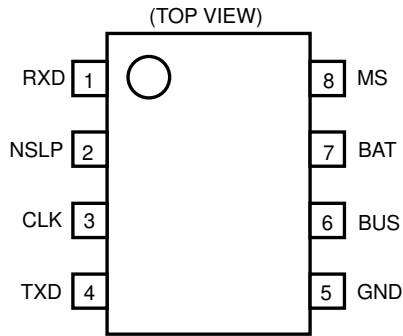

Figure 2. Pin Configuration

Pin Description

Table 1. Pin Description

Pin No.	Pin Name	Function
1	RXD	Received data output pin
2	NSLP	Power saving control input pin ("H" : Change to "Codec mode", "L" : Change to "Power OFF mode")
3	CLK	Clock signal input/output pin (Master setting: Input, Slave setting: Output)
4	TXD	Transmission data input pin
5	GND	Ground
6	BUS	CXPI BUS pin
7	BAT	Power supply pin
8	MS	Master/Slave switching pin ("H": Master, "L": Slave)

Block Diagram

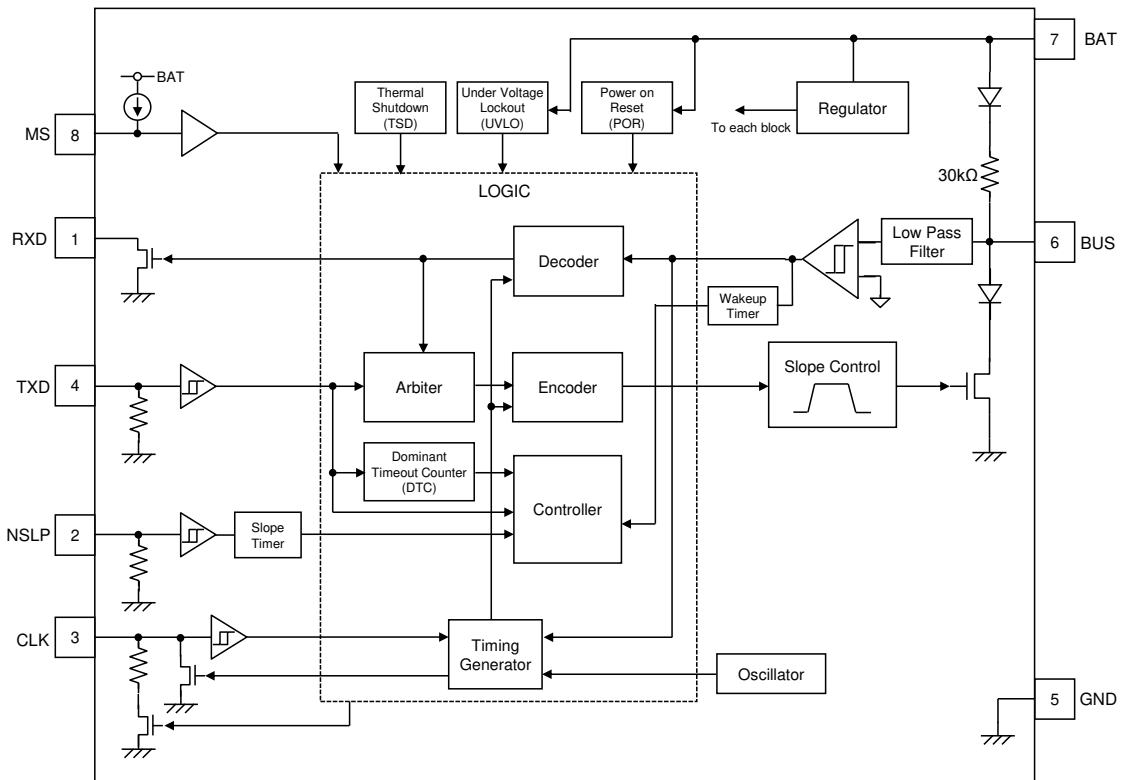

Figure 3. Block Diagram

Description of Blocks

State Transition Diagram

BD41000AFJ-C is built-in “Power OFF Mode”, “Through Mode”, “RX Through Mode” other than “CODEC Mode” for power saving control. Each mode is controlled by NSLP, BUS, and TXD pins.

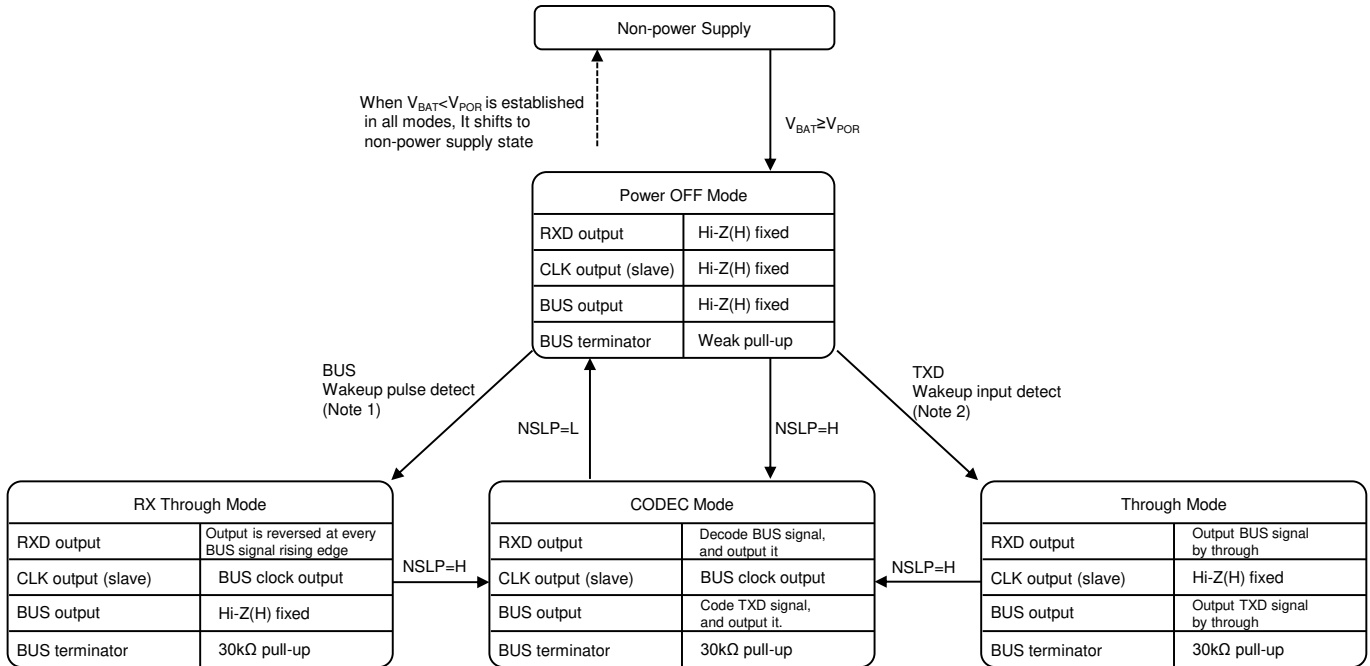

Figure 4. State Transition Diagram

Please refer to the following parameter of the electrical characteristic about (Note 1) and (Note 2).
 (Note 1): Wakeup pulse detection LO time, (Note 2): Wakeup input detection time (TXD)

While using master, CLK becomes input pin, and uses to input BUS clock in CODEC mode

Power OFF Mode

“Power OFF Mode” reduces power consumption by not supplying powers to any circuits other than necessary ones for “Wakeup pulse detection (BUS)” and “Wakeup input detection (TXD)”.

When TXD is “H”, Wakeup input is detected, and then changes to “Through mode”. In the case of shifts to “Power OFF Mode”, TXD is “L”, and then NSLP is “L”.

“Through Mode” and “RX Through mode” cannot change to “Power OFF Mode” directly. Please change via “CODEC Mode” with NSLP as “H”.

Through Mode

“Through mode” does not process Coding/Decoding. It only drives signals from TXD to BUS and from BUS to RXD directly.

Please change to “Through mode” with TXD as “H” to send Wakeup pulse.

RX Through Mode

“RX Through Mode” reverses RXD output at each rising edge of BUS.

Please monitor the change of RXD to detect Wakeup pulse in “Power OFF Mode”.

CODEC Mode

“CODEC Mode” is the mode of CXPI communication. NSLP should be “H” for the chip to enter “CODEC Mode”.

Outputs in the case of Master setting are changed by the falling edge of CLK, and in the case of Slave setting are changed by the falling edge of BUS. BUS signal is delayed 2.0 ± 0.5 Tbit from TXD input, and RXD is delayed 1.0 ± 0.5 Tbit from BUS input.

The jitter of CLK input should satisfy the CXPI standard ($\pm 1.0\%$) including the effect of BD41000AFJ-C ($\pm 0.05\%$) in the case of Master setting.

Sequence Diagram

It shows the example of BD41000AFJ-C control sequence (“Sleep Mode”, “Standby Mode” and “Normal Mode”) corresponding to the CXPI standard. (Please refer to the CXPI standard for specifications about the detail of mode management.)

1. The Sequence from “Normal Mode” to “Sleep Mode”

When changing to “Sleep Mode”, NSLP should be switched from “H” to “L”, and then the IC turns to “Power OFF Mode”. TXD has built-in pull-down resistor in case of a fail-safe. In “Sleep Mode”, set TXD to “L” before BD41000AFJ-C enters “Power OFF Mode” to prevent extra currents from MCU side.

Set CLK to “L” just like TXD, because the pull-down resistor of CLK is active in the case of Master setting.

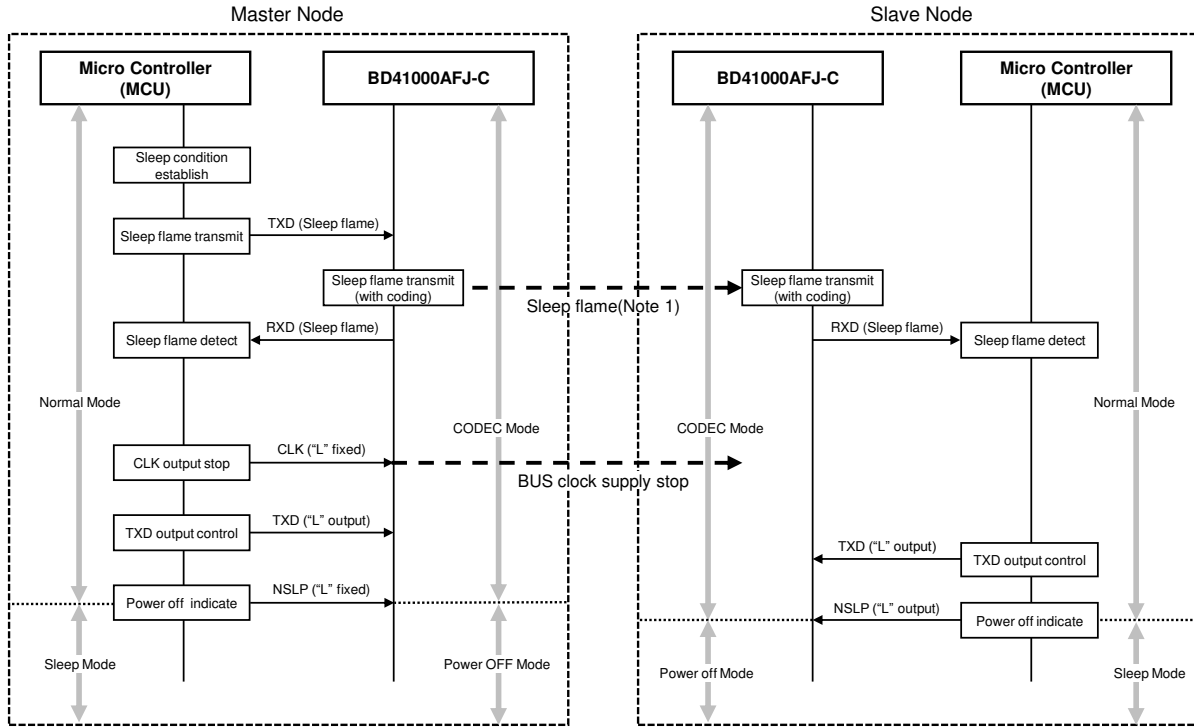

Note 1 Please refer to the CXPI standard about Sleep flame.

Figure 5. The Sequence from “Normal Mode” to “Sleep Mode”

Master Node

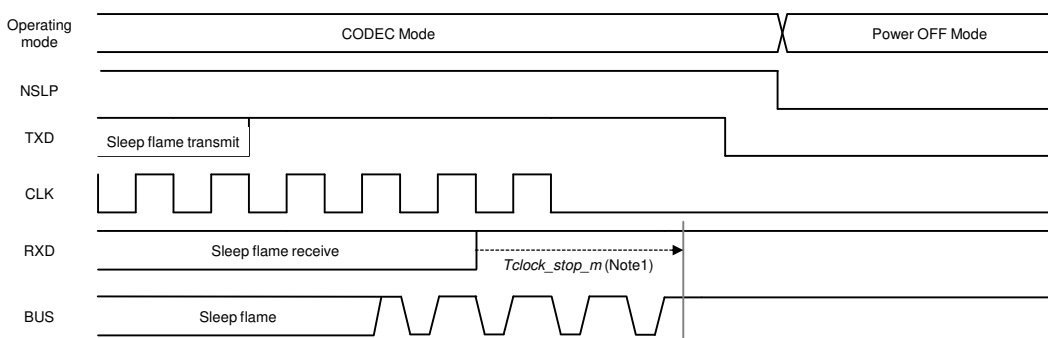

Note 1 Please refer to the CXPI standard about Tclock_stop_m.

Figure 6. The Timing Chart from “Normal Mode” to “Sleep Mode” (Master)

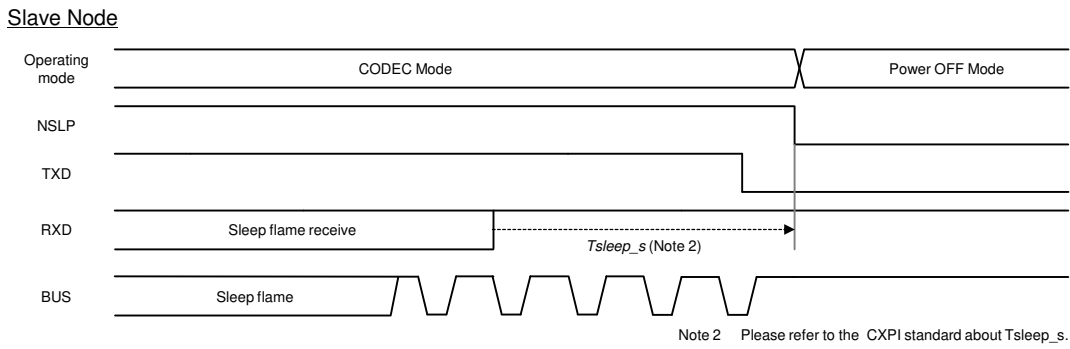

Figure 7. The Timing Chart from “Normal Mode” to “Sleep Mode” (Slave)

2. The Sequence from “Sleep Mode” to “Normal Mode” (Master Node Trigger)

To wake up the node by an internal factor, set NSLP to “H” for the chip to enter “CODEC Mode”. TXD should be “H” for about 30µs before changing from “Power OFF Mode” to “CODEC Mode” in order to prevent abnormal outputs of BUS or RXD.

In the case of slave mode, BD41000AFJ-C reverses RXD output at every rising edge of BUS signal after receiving BUS clock. When detecting first RXD falling edge, please start micro controller initializing operation. To establish wakeup pulse, please check if RXD output is “H” or detect RXD rising edge after initializing operation.

To change from “Standby Mode” to “Sleep Mode” because the slave node cannot receive the second rising pulse within the specified time, please return to “Power OFF Mode” with NSLP as “L” again after the change to “CODEC Mode” with NSLP as “H”.

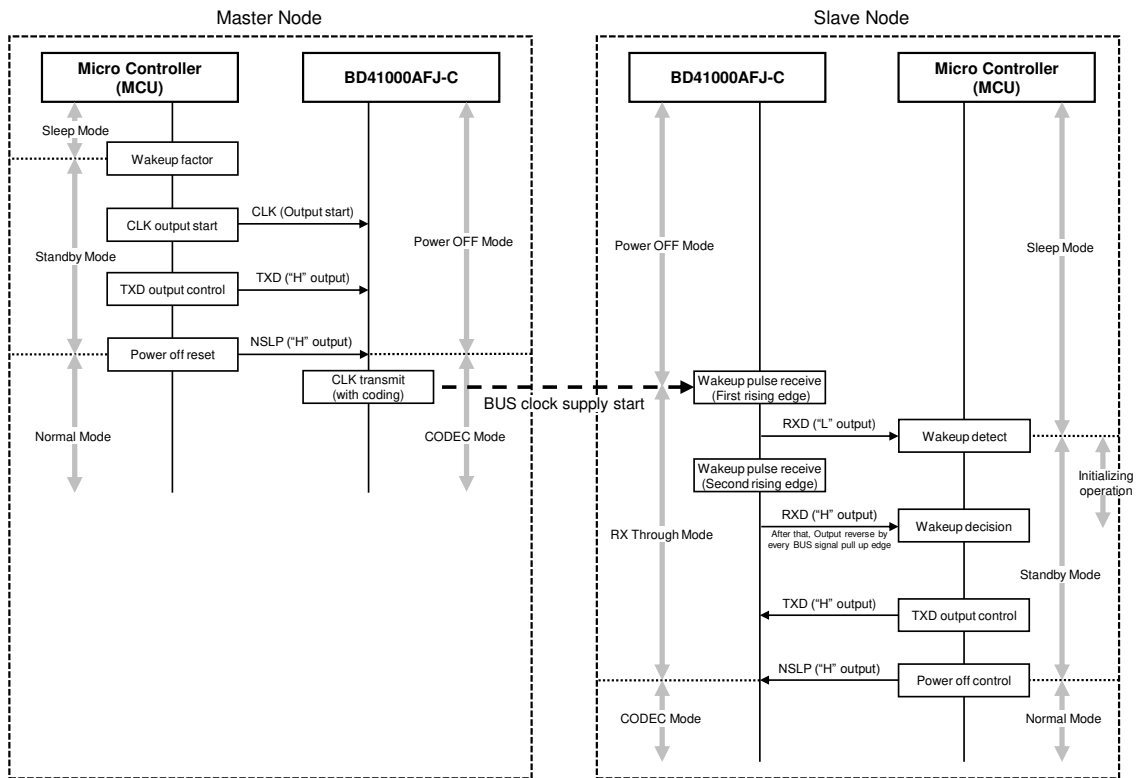

Figure 8. The Sequence from “Sleep Mode” to “Normal Mode” (Master Node Trigger)

Master Node

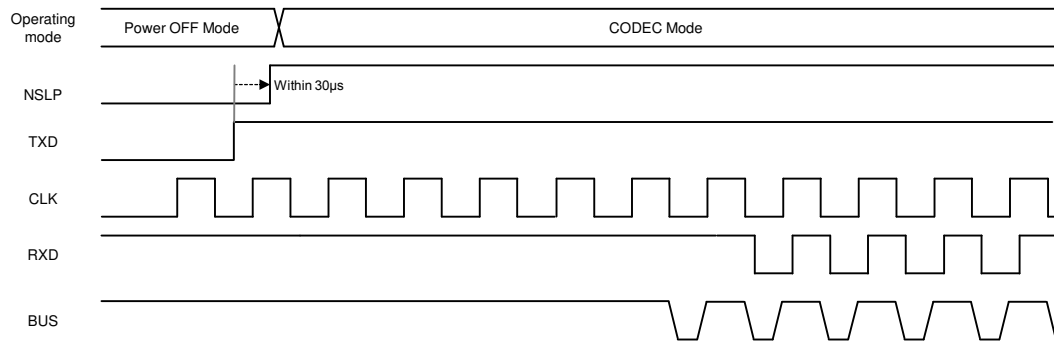

Figure 9. The Timing Chart from "Sleep Mode" to "Normal Mode" (Master Node Trigger, Master)

Slave Node

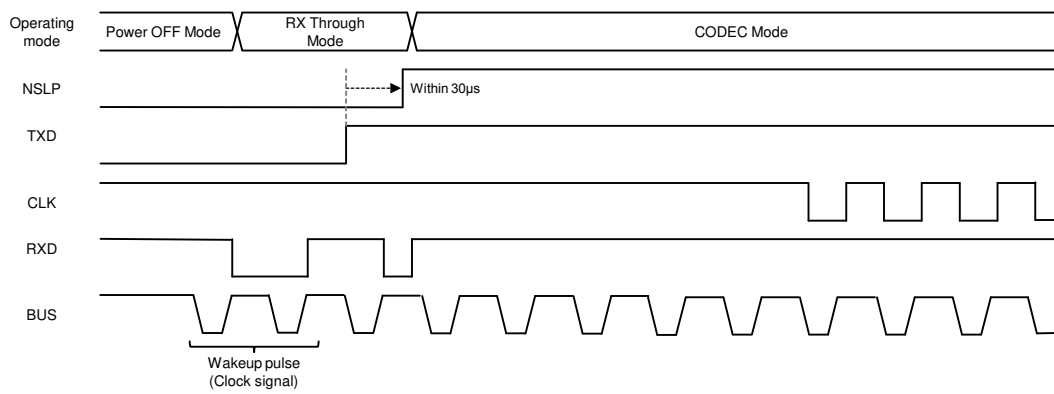

Figure 10. The Timing Chart from "Sleep Mode" to "Normal Mode" (Master Node Trigger, Slave)

3. The Sequence from “Sleep Mode” to “Normal Mode” (Slave Node Trigger)

To wake up the slave node by an internal factor, set TXD to “H” for the chip to enter “Through Mode”. After receiving the wakeup pulse in the Master Node, RXD output reverses at every rising edge of the BUS signal. It is better to establish Wakeup at clock’s first falling edge. To change from “Standby Mode” to “Sleep Mode”, in case the master node cannot receive BUS clock within the specified time, set NSLP to “L” to return to “Power OFF Mode” then enter to “CODEC Mode” by setting NSLP to “H”.

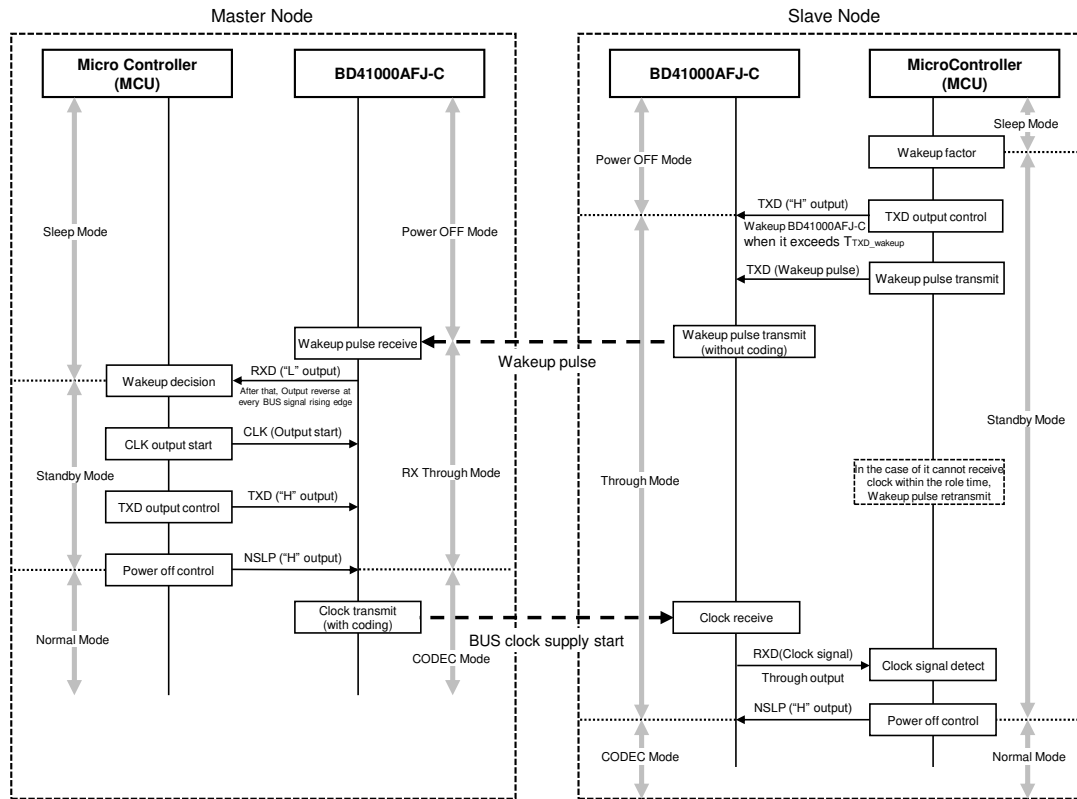
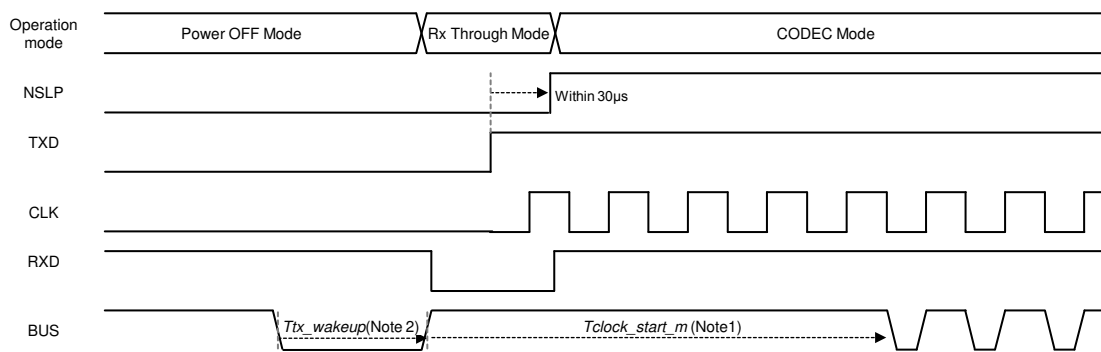

Figure 11. The Sequence from “Sleep Mode” to “Normal Mode” (Slave Node Trigger)

Master Node



Note 1,2 Please refer to the CXPI standard about Tclock_start_m, Ttx_wakeup.

Figure 12. The Timing Chart from “Sleep Mode” to “Normal Mode” (Slave Node Trigger, Master)

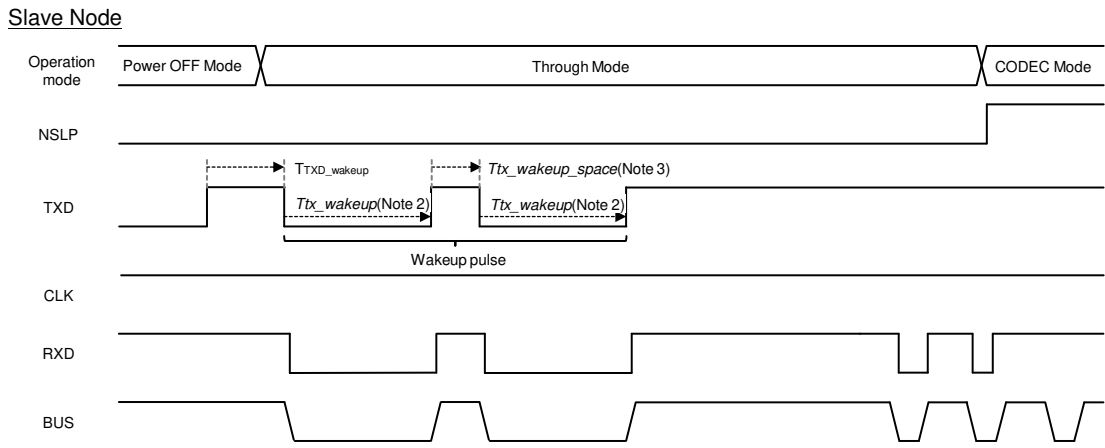

Note2,3 Please refer to the CXPI standard about Ttx_wakeup, Ttx_wakeup_space

Figure 13. The Timing Chart from “Sleep Mode” to “Normal Mode” (Slave Node Trigger, Slave)

Transmission and Reception Started Effective Time after Shift to CODEC Mode

To detect clock sequence is to learn the LO width of logic value1 during “CODEC Mode” with NSLP as “H”. To keep learning it, please start to transmit and receive data after the time equal to 16 Tbit clocks at least. (6 Tbit clocks are necessary until BUS clock is outputted by BUS or CLK after NSLP as “H”.)

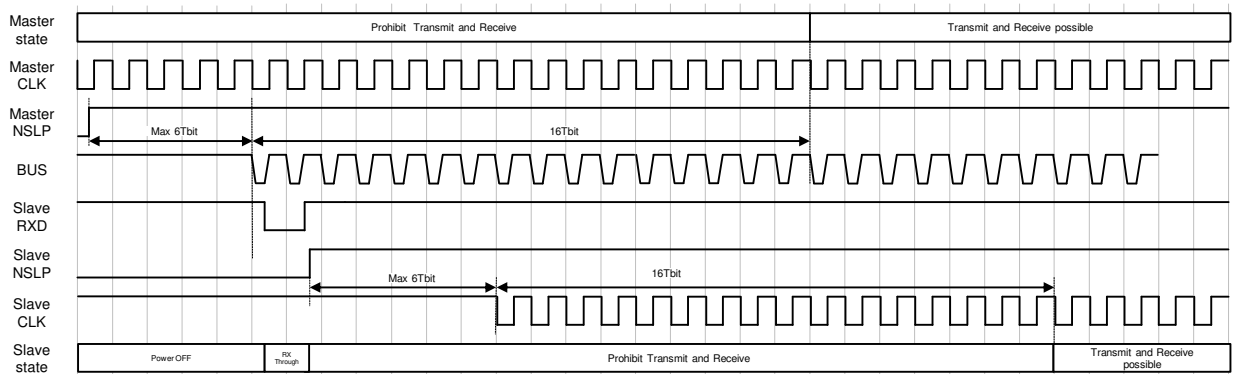

Figure 14. The Actual Time of Transmission and Reception after “CODEC Mode” Changing

Arbitration Function

To carry out collision resolution functions that defined by CXPI specification, both micro controller and BD41000AFJ-C share functions. Basically, BD41000AFJ-C arbitrates between UART bit data and micro controller arbitrates between UART byte data.

1. In case of collision is happened by transmitting from other node at the same time

In the case of collision (arbitration defeat) after data transmission by other node on BUS, it stops the transmission of remaining UART frame data at the collision. It is necessary to have the interval 1Tbit or more (BUS baud rate period) to transmit again after arbitration defeat. Set the wait time in consideration of the frequency deviation of the baud rate clock in micro controller side and BUS side and the delay at UART circuit in micro controller side.

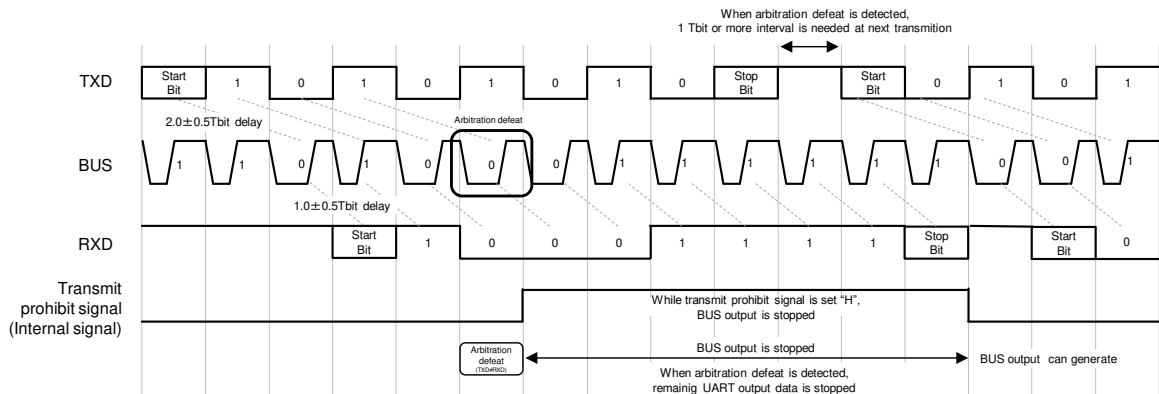

Figure 15. Arbitration Function (When the Collision is detected after Data Transmission)

2. In case of collision is detected by receiving from other node before transmission is started.

BD41000AFJ-C has built-in function to stop transmission upon detection of BUS data collision. When the signal is detected on BUS before the start of transmit data, BD41000AFJ-C stops to transmit data for 10 Tbit period, and then while stopping to transmit data, if TXD signal is inputted to BD41000AFJ-C, BD41000AFJ-C stops to transmit data for further 10 Tbit period of the transmit data.

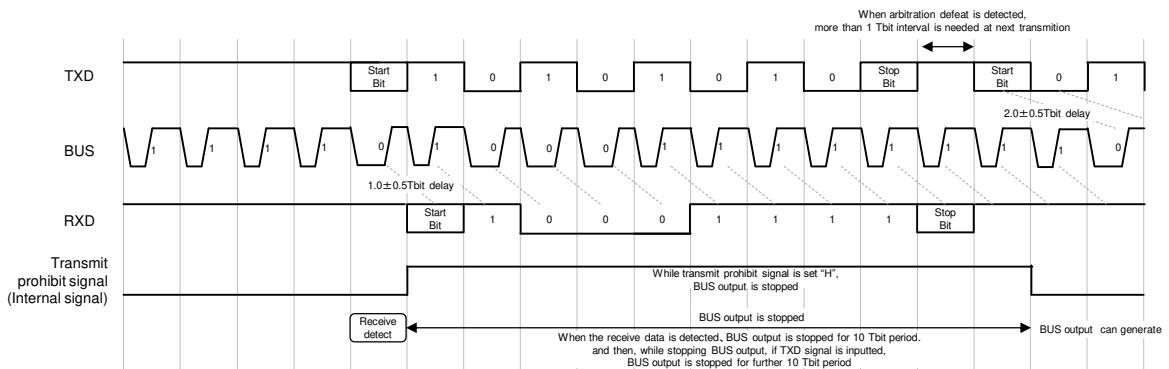

Figure 16. Arbitration Function (When receive data is detected before transmission data)

3. In case of collision function failure is happed when micro controller outputs transmission data to BD41000AFJ-C between the outside range of BD41000AFJ-C arbitration function.

BUS output is delayed 2.5 Tbit(Max.) from TXD input and RXD output is delayed 1.5 Tbit(Max.) from BUS input. When micro controller outputs transmission data to BD41000AFJ-C at the timing that shown in Figure 17, CXPI frame of other node is destroyed because BD41000AFJ-C outputs PID just after receive PID. Micro controller should stop transmission data to BD41000AFJ-C while receiving UART data. Figure 17 shows the example in case of 2.0 Tbit delay from TXD input to BUS output and 1.0 Tbit delay from BUS input to RXD output.

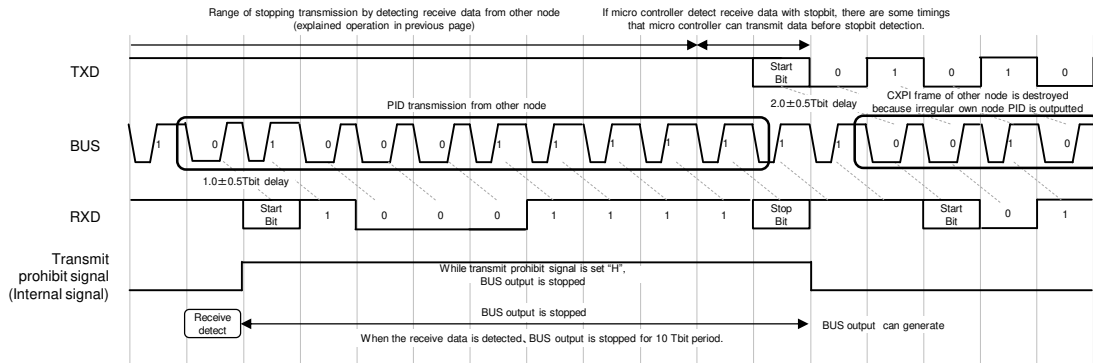

Figure 17. Arbitration Function (When micro controller detect receive data with stopbit)

Fail-safe Mode

BD41000AFJ-C has built in fail-safe mode such as DTC (TXD Dominant Abnormal Detection Circuit), TSD (Abnormal Thermal Detection Circuit) and UVLO/POR (Abnormal Under Voltage Detection Circuit). The operations of each abnormality situation are as follows;

Table 2. Fail-safe Functions

Fail-safe Function	State Transition	BUS Output	RXD Output	CLK Output (While using slave)
DTC abnormality	No change	CODEC Mode : Logical value1 output ^(Note 1) Through Mode : Hi-Z(H) fixed	BUS signal output	Hi-Z (H) fixed
TSD abnormality	No change	Hi-Z (H) fixed	Hi-Z (H) fixed	Hi-Z (H) fixed
UVLO abnormality	No change	Hi-Z (H) fixed	Hi-Z (H) fixed	Hi-Z (H) fixed
POR abnormality	Power OFF Mode	Hi-Z (H) fixed	Hi-Z (H) fixed	Hi-Z (H) fixed

(Note 1) In the case of TXD fixed L, Logical value0 is outputted only in first 10bit. Logical value1 is outputted before DTC abnormality is detected.

When “L” time of TXD is more than T_{DTC} , DTC (Dominant Timeout Counter) detects abnormality, and then it stops output. It can return to normal status with TXD as “H”

When the junction temperature exceeds T_{TSD} , TSD (Thermal Shutdown) circuit detects abnormality, and then it stops output. It can return to normal status when the temperature drops below T_{TSD_HYS} .

Operations of UVLO (Under Voltage Lockout) and POR (Power ON Reset) are as follows; When supply voltage drops below V_{UVLO} , UVLO abnormality is detected, and then BUS, RXD and CLK outputs are fixed Hi-Z (H). (Only slave)

When power supply exceeds V_{UVLO} , transceiver restarts output. When supply voltage drops below V_{POR} , POR abnormality is detected, and then it changes to “Power OFF Mode”, and reset status.

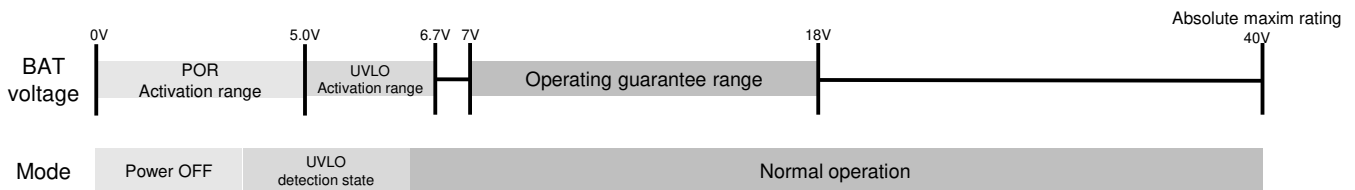

Figure 18. Internal Status and Mode by Supply Voltage

Absolute Maximum Ratings (Ta = 25°C)

Table 3. Absolute Maximum Ratings (Ta = 25°C)

Parameter	Symbol	Rating	Unit
Supply Voltage on Pin BAT ^(Note 1)	V _{BAT}	-0.3 to +40.0	V
MS Voltage	V _{MS}	-0.3 to +40.0	V
BUS Voltage	V _{BUS}	-27.0 to +40.0	V
CLK, TXD, RXD, NSLP voltage	V _{MCU}	-0.3 to +7.0	V
Power Dissipation ^(Note 2)	P _d	0.67	W
Storage Temperature Range	T _{stg}	-55 to +150	°C
Junction Max Temperature	T _{jmax}	150	°C
Electro Static Discharge (HBM) ^(Note 3)	V _{ESD}	4000	V

(Note 1) P_d, ASO should not be exceeded.

(Note 2) Regarding above Ta=25°C, P_d decreased at 5.40mW/°C for temperatures when mounted on 70x70x1.6mm Glass-epoxy PCB.

(Note 3) JEDEC qualified.

Caution: Operating the IC over the absolute maximum ratings may damage the IC. The damage can either be a short circuit between pins or an open circuit between pins and the internal circuitry. Therefore, it is important to consider circuit protection measures, such as adding a fuse, in case the IC is operated over the absolute maximum ratings.

Recommended Operating Conditions

Table 4. Recommended Operating Conditions

Parameter	Symbol	Rating	Unit
BAT Supply Voltage Range	V _{BAT}	+7 to +18	V
Operating Temperature Range	T _{opr}	-40 to +125	°C

Electrical Characteristics (Unless Otherwise Specified Ta=-40°C to +125°C, VBAT=7V to 18V)

Table 5. Electrical Characteristics (1)

Parameter	Symbol	Min	Typ	Max	Unit	Conditions
BAT						
Supply Current 1	I _{BAT_SLP}	-	3	10	μA	After NSLP Shifts from H to L
Supply Current 2	I _{BAT_NOR}	-	3	10	mA	NSLP=H, MS=H, CLK=20kHz (Duty=50%) TXD=10kHz (Duty=50%)
TXD, NLSP, CLK (When Input)						
V _{IH}	V _{IH_MCU_IN}	2.0	-	-	V	
V _{IL}	V _{IL_MCU_IN}	-	-	0.8	V	
Input H Current	I _{IH_MCU_IN}	6.0	14.0	40.0	μA	Input Voltage=5V
Input L Current	I _{IL_MCU_IN}	-5.0	0.0	5.0	μA	
Wakeup Input Detection Time (TXD)	T _{TXD_wakeup}	30	100	150	μs	H Width
Input Clock Duty (CLK)	Duty _{CLK}	48	50	95	%	Duty Rule of H Width
MS						
V _{IH}	V _{IH_MS_IN}	V _{BAT} -1.0	-	-	V	
V _{IL}	V _{IL_MS_IN}	-	-	V _{BAT} -3.0	V	
Input H Current	I _{IH_MS_IN}	-5.0	-	5.0	μA	Input Voltage= V _{BAT} =18V
Input L Current	I _{IL_MS_IN}	-5.0	-	5.0	μA	In Power OFF Mode
RXD, CLK (When Output)						
Output ON Current	O _{IL_MCU_OUT}	1.3	3.5	-	mA	Output Pin=0.4V
Output OFF Current	O _{IH_MCU_OUT}	-5.0	0.0	5.0	μA	Output Pin =5V
BUS (DC Characteristics)						
Recessive Output Voltage ^(Note 1)	V _{BUS_RES}	V _{BAT} x 0.9	-	-	V	R _L =500Ω
Dominant Output Voltage 1 ^(Note 1)	V _{BUS_DOM_1}	-	-	1.2	V	V _{BAT} =7V, R _L =500Ω
Dominant Output Voltage 2 ^(Note 1)	V _{BUS_DOM_2}	0.6	-	-	V	V _{BAT} =7V, R _L =1kΩ
Dominant Output Voltage 3 ^(Note 1)	V _{BUS_DOM_3}	-	-	2.0	V	V _{BAT} =18V, R _L =500Ω
Dominant Output Voltage 4 ^(Note 1)	V _{BUS_DOM_4}	0.8	-	-	V	V _{BAT} =18V, R _L =1kΩ
H Level Leakage Current	I _{IH_BUS}	-5.0	0.0	5.0	μA	When Recessive Output V _{BAT} = V _{BUS} =18V
Pull-up Resistor	R _{BUS}	20	30	50	kΩ	V _{BAT} =12V
Short-circuit Output Current ^(Note 1)	I _{OCP_BUS}	40	-	200	mA	V _{BAT} = V _{BUS} =18V, R _L =0Ω
L Current at Receiver Operating	I _{OL_BUS}	-1	-	-	mA	V _{BAT} =12V, V _{BUS} =0V
Input Leakage Current at Receiver Operating	I _{LBUS}	-	-	20	μA	V _{BAT} =8V, V _{BUS} =18V
Leakage Current when NO_GND	I _{LBUS_NO_GND}	-1	-	1	mA	GND=V _{BAT} =12V, V _{BUS} =0V to 18V
Leakage Current when NO_BAT	I _{LBUS_NO_BAT}	-	-	100	μA	V _{BAT} =0V, V _{BUS} =0V to 18V
Input H Threshold Voltage	V _{IH_BUS_REC}	V _{BAT} x 0.556	-	-	V	
Input L Threshold Voltage	V _{IL_BUS_DOM}	-	-	V _{BAT} x 0.423	V	
Input Threshold Voltage (Typical)	V _{THC_BUS}	V _{BAT} x 0.475	V _{BAT} x 0.5	V _{BAT} x 0.525	V	
Input Hysteresis Voltage	V _{HYS_BUS}	-	-	V _{BAT} x 0.133	V	

(Note 1) R_L is pullup resistor that is connected between BAT and BUS terminal outside.

Table 6. Electrical Characteristics (2)

Parameter	Symbol	Min	Typ	Max	Unit	Conditions
BUS (AC Characteristics)						
LO Level Time 1 of Logical Value "1" (Note 2)	$T_{tx_1_lo_rec}$	-	-	$0.39T_{bit} + 0.6\tau$	-	$TH_{rec}=70\%$
LO Level Time 2 of Logical Value "1"	$T_{tx_1_lo_dom}$	0.11	-	-	T_{bit}	$TH_{dom}=30\%$
HI Detection Time of Receiving	$T_{tx_0_hi}$	0.06	-	-	T_{bit}	$TH_{rec}=55.6\%$
Difference of LO Level Time Between Logical Value "1" and Logical Value "0"	T_{tx_dif}	0.06	-	-	T_{bit}	$T_{tx_dif} = T_{tx_0_lo} - T_{tx_1_lo}$
Delay Time from the LO Level Detection to Logical Value "0" Output	$T_{tx_0_pd}$	-	-	0.11	T_{bit}	$TH_{dom}=30\%$
LO time 1 of Logical Value "0"	$T_{tx_0_lo_rec}$	$T_{tx_1_lo_rec} + 0.06$	-	-	T_{bit}	$TH_{rec}=70\%$
LO time 2 of Logical Value "0"	$T_{tx_0_lo_dom}$	$T_{tx_1_lo_dom} + 0.06$	-	-	T_{bit}	$TH_{dom}=30\%$
BUS Pull-down Time	$T_{tx_1_dom_m}$	-	-	0.16	T_{bit}	$TH_{dom}=30\%$
Recessive Voltage of Logical Value "0"	V_{rec_0}	93	-	-	%	Ratio for the Recessive voltage (V_{rec_1}) when logical value is 1
Wakeup Pulse Detection LO Time for Master Setting	$T_{rx_wakeup_master}$	30	100	150	μs	$TH_{dom}=42.3\%$
Wakeup Pulse Detection LO Time for Slave Setting	$T_{rx_wakeup_slave}$	0.5	3	5	μs	$TH_{dom}=42.3\%$
TSD						
TSD Detection Temperature (Note 3)	T_{TSD}	150	-	200	$^{\circ}C$	
TSD Hysteresis Temperature (Note 3)	T_{TSD_HYS}	-	14	-	$^{\circ}C$	
UVLO						
UVLO Detection Voltage	V_{UVLO}	5.0	-	6.7	V	
POR						
POR Detection Voltage	V_{POR}	-	-	5.0	V	
DTC						
Dominant Time-out Time	T_{DTC}	9	13	22	ms	

(Note 2) τ is a fixed number when BUS ($1\mu s \leq \tau \leq 5\mu s$)

(Note 3) It is a design guarantee parameter, and is not production tested.

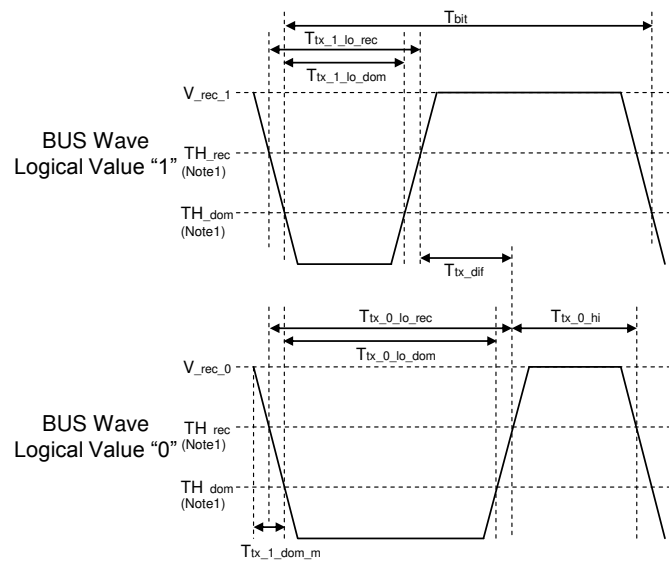

Note1 These parameters show the ratio for V_{BAT} .

Figure 19. BUS Waves of Logical Value 1, 0

Application Example

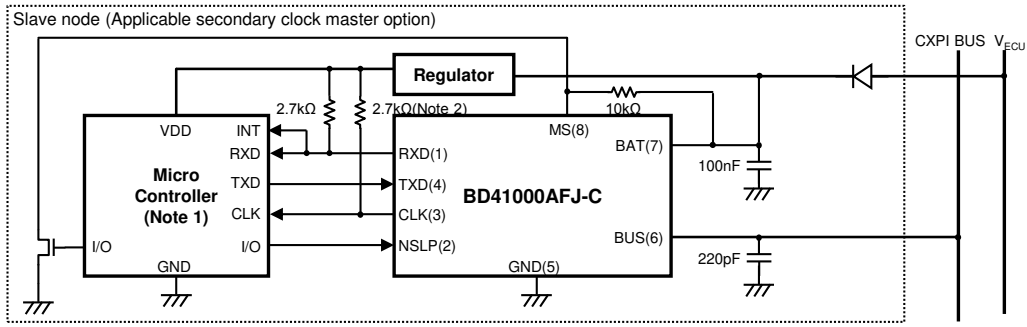

Note 1 INT: Interrupt, RXD: UART RXD, TXD: UART TXD, CLK: Clock, I/O: General Purpose I/O
 Note 2 While using slave, Pullup register is no need for CLK in the case of non-using CLK output.

Figure 20. Application Example of Secondary Clock Master Option

Power Dissipation

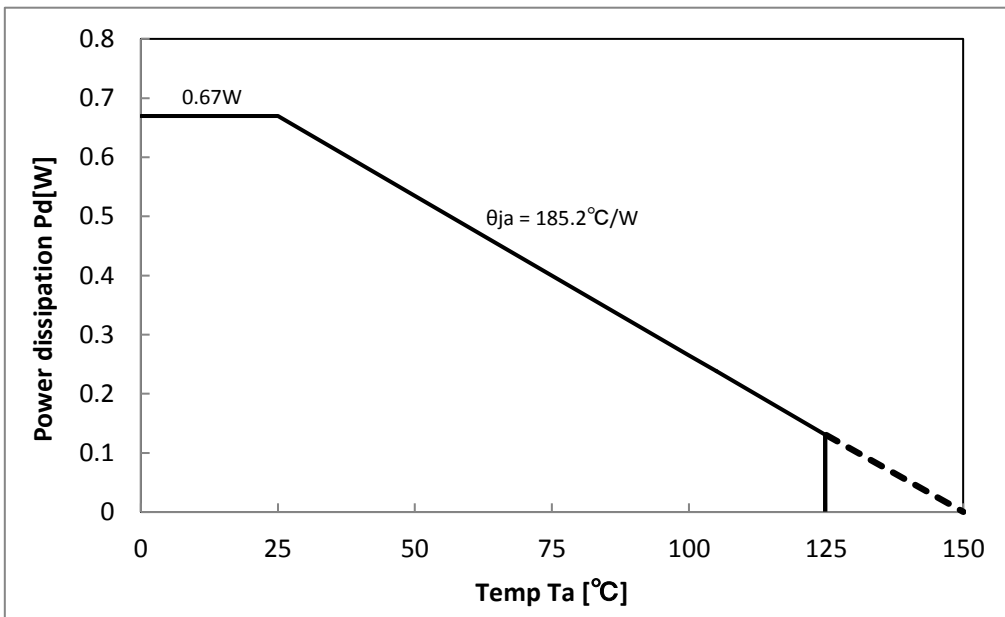

Figure 21. Power Dissipation

- (Note 1) Measured Board (70mm x 70mm x 1.6mm, glass epoxy 1-layer)
- (Note 2) These values are changed by number of layer and copper foil area.

I/O Equivalent Circuits

Type	Equivalence Circuit	Type	Equivalence Circuit
A	<p>Output pin: RXD</p>	B	<p>Input pin: NSLP, TXD</p>
C	<p>Input/output pin: CLK</p>	D	<p>CXPI BUS Input/output pin: BUS</p>
E	<p>Input pin: MS</p>		

Operational Notes

1. Reverse Connection of Power Supply

Connecting the power supply in reverse polarity can damage the IC. Take precautions against reverse polarity when connecting the power supply, such as mounting an external diode between the power supply and the IC's power supply pins.

2. Power Supply Lines

Design the PCB layout pattern to provide low impedance supply lines. Furthermore, connect a capacitor to ground at all power supply pins. Consider the effect of temperature and aging on the capacitance value when using electrolytic capacitors.

3. Ground Voltage

Ensure that no pins are at a voltage below that of the ground pin at any time, even during transient condition.

4. Ground Wiring Pattern

When using both small-signal and large-current ground traces, the two ground traces should be routed separately but connected to a single ground at the reference point of the application board to avoid fluctuations in the small-signal ground caused by large currents. Also ensure that the ground traces of external components do not cause variations on the ground voltage. The ground lines must be as short and thick as possible to reduce line impedance.

5. Thermal Consideration

Should by any chance the maximum junction temperature rating be exceeded the rise in temperature of the chip may result in deterioration of the properties of the chip. In case of exceeding this absolute maximum rating, increase the board size and copper area to prevent exceeding the maximum junction temperature rating.

6. Recommended Operating Conditions

These conditions represent a range within which the expected characteristics of the IC can be approximately obtained. The electrical characteristics are guaranteed under the conditions of each parameter.

7. Inrush Current

When power is first supplied to the IC, it is possible that the internal logic may be unstable and inrush current may flow instantaneously due to the internal powering sequence and delays, especially if the IC has more than one power supply. Therefore, give special consideration to power coupling capacitance, power wiring, width of ground wiring, and routing of connections.

8. Operation Under Strong Electromagnetic Field

Operating the IC in the presence of a strong electromagnetic field may cause the IC to malfunction.

9. Testing on Application Boards

When testing the IC on an application board, connecting a capacitor directly to a low-impedance output pin may subject the IC to stress. Always discharge capacitors completely after each process or step. The IC's power supply should always be turned off completely before connecting or removing it from the test setup during the inspection process. To prevent damage from static discharge, ground the IC during assembly and use similar precautions during transport and storage.

10. Inter-pin Short and Mounting Errors

Ensure that the direction and position are correct when mounting the IC on the PCB. Incorrect mounting may result in damaging the IC. Avoid nearby pins being shorted to each other especially to ground, power supply and output pin. Inter-pin shorts could be due to many reasons such as metal particles, water droplets (in very humid environment) and unintentional solder bridge deposited in between pins during assembly to name a few.

11. Unused Input Pins

Input pins of an IC are often connected to the gate of a MOS transistor. The gate has extremely high impedance and extremely low capacitance. If left unconnected, the electric field from the outside can easily charge it. The small charge acquired in this way is enough to produce a significant effect on the conduction through the transistor and cause unexpected operation of the IC. So unless otherwise specified, unused input pins should be connected to the power supply or ground line.

Operational Notes – continued

12. Regarding the Input Pin of the IC

This monolithic IC contains P+ isolation and P substrate layers between adjacent elements in order to keep them isolated. P-N junctions are formed at the intersection of the P layers with the N layers of other elements, creating a parasitic diode or transistor. For example (refer to figure below):

When $GND > Pin\ A$ and $GND > Pin\ B$, the P-N junction operates as a parasitic diode.

When $GND > Pin\ B$, the P-N junction operates as a parasitic transistor.

Parasitic diodes inevitably occur in the structure of the IC. The operation of parasitic diodes can result in mutual interference among circuits, operational faults, or physical damage. Therefore, conditions that cause these diodes to operate, such as applying a voltage lower than the GND voltage to an input pin (and thus to the P substrate) should be avoided.

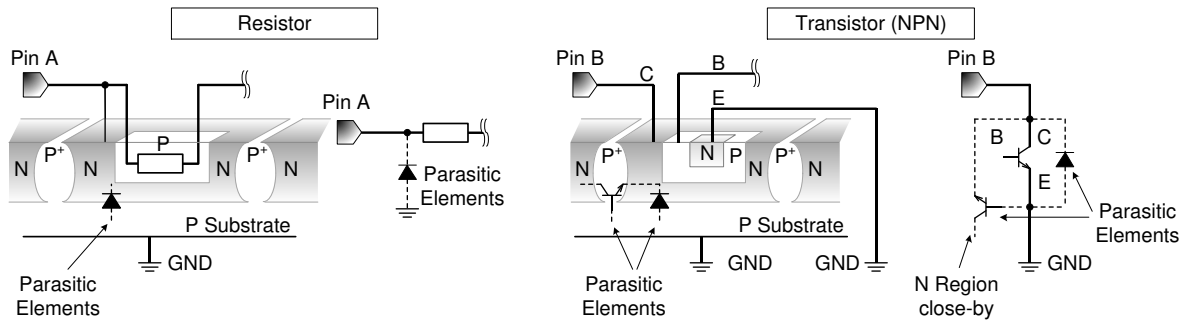

Figure 22. Example of Monolithic IC Structure

13. Ceramic Capacitor

When using a ceramic capacitor, determine the dielectric constant considering the change of capacitance with temperature and the decrease in nominal capacitance due to DC bias and others.

14. Area of Safe Operation (ASO)

Operate the IC such that the output voltage, output current, and the maximum junction temperature rating are all within the Area of Safe Operation (ASO).

15. Thermal Shutdown Circuit(TSD)

This IC has a built-in thermal shutdown circuit that prevents heat damage to the IC. Normal operation should always be within the IC's maximum junction temperature rating. If however the rating is exceeded for a continued period, the junction temperature (T_j) will rise which will activate the TSD circuit that will turn OFF all output pins. When the T_j falls below the TSD threshold, the circuits are automatically restored to normal operation.

Note that the TSD circuit operates in a situation that exceeds the absolute maximum ratings and therefore, under no circumstances, should the TSD circuit be used in a set design or for any purpose other than protecting the IC from heat damage.

Ordering Information

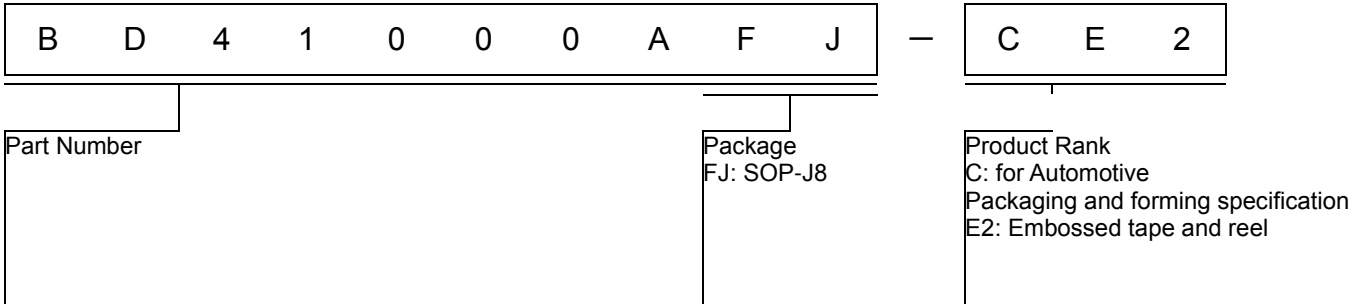

Marking Diagrams

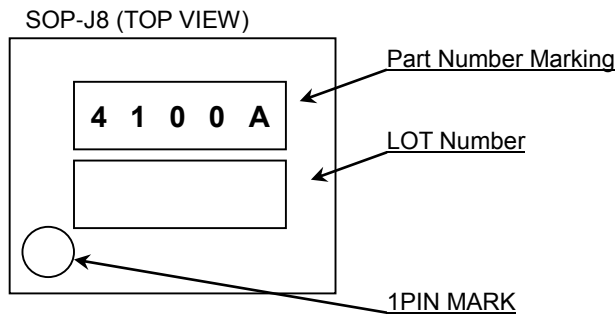

Part Number Marking	Package	Orderable Part Number
4100A	SOP-J8	BD41000AFJ-CE2

Physical Dimension, Tape and Reel Information

Package Name	SOP-J8
--------------	--------

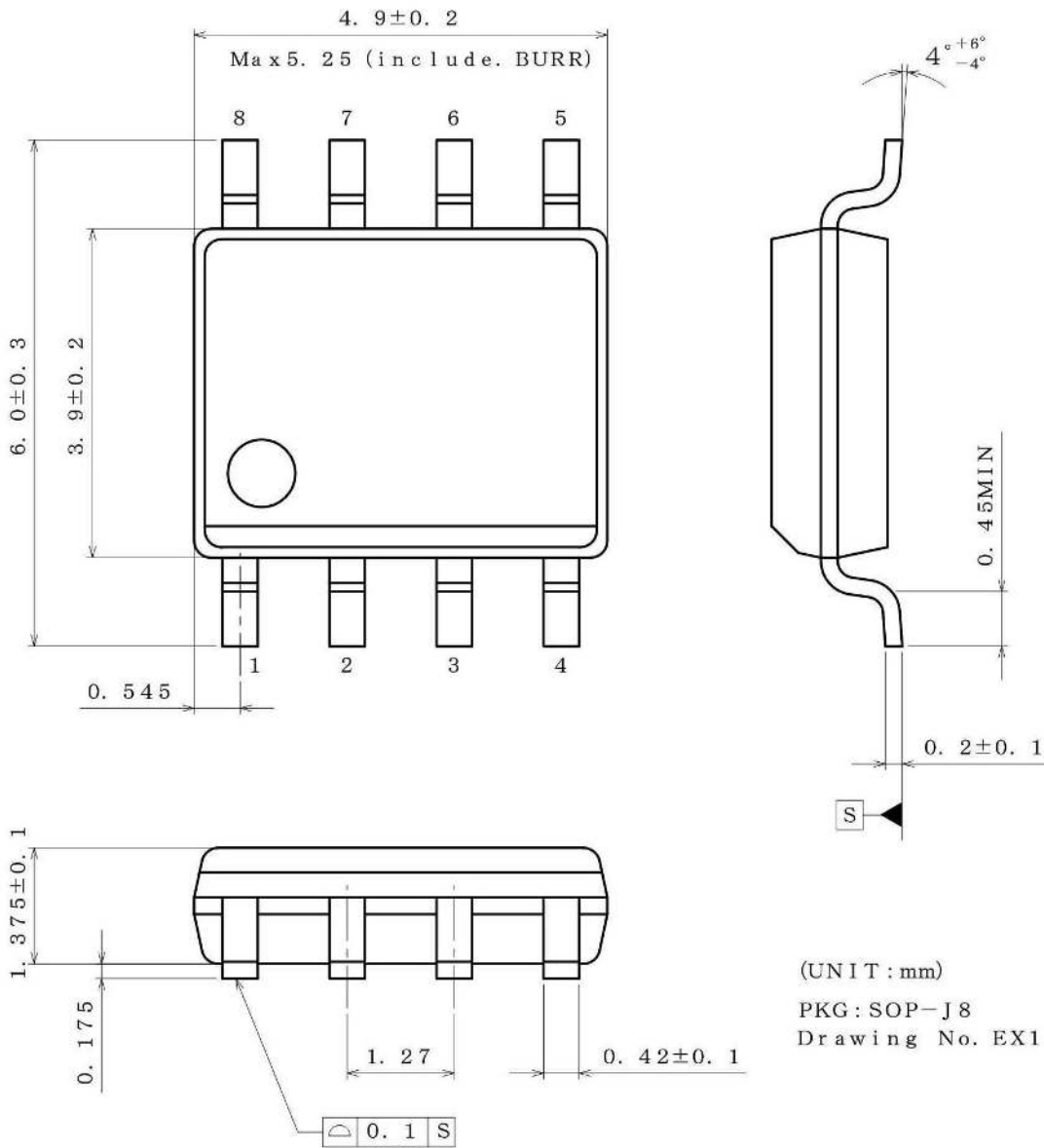

(UNIT : mm)
 PKG : SOP-J8
 Drawing No. EX1111-5002

<Tape and Reel information>

Tape	Embossed carrier tape
Quantity	2500pcs
Direction of feed	E2 (The direction is the 1pin of product is at the upper left when you hold reel on the left hand and you pull out the tape on the right hand)

Revision History

Date	Revision	Changes
08.Aug.2017	001	New Release (For additional information, the changed contents is shown from BD41000FJ-C Rev0.02) All Modified from BD41000FJ-C to BD41000AFJ-C P5 Added detail information about wakeup decision method of slave node P7 Added detail information about wakeup decision method of master node P9,P10 Modified arbitration function explanation P18 Modified ordering information and marking diagrams
21.Seq.2017	002	P12 Added explanation of R _L
26.Mar.2019	003	P1 Added the ApplicationNote information P9 1. In case of collision is happened by transmitting from other node at the same time Added a caution about the time to validate the transmit after an arbitration defeat occurred.

Notice

Precaution on using ROHM Products

1. If you intend to use our Products in devices requiring extremely high reliability (such as medical equipment ^(Note 1), aircraft/spacecraft, nuclear power controllers, etc.) and whose malfunction or failure may cause loss of human life, bodily injury or serious damage to property ("Specific Applications"), please consult with the ROHM sales representative in advance. Unless otherwise agreed in writing by ROHM in advance, ROHM shall not be in any way responsible or liable for any damages, expenses or losses incurred by you or third parties arising from the use of any ROHM's Products for Specific Applications.

(Note1) Medical Equipment Classification of the Specific Applications

JAPAN	USA	EU	CHINA
CLASS III	CLASS III	CLASS II b	CLASS III
CLASS IV		CLASS III	

2. ROHM designs and manufactures its Products subject to strict quality control system. However, semiconductor products can fail or malfunction at a certain rate. Please be sure to implement, at your own responsibilities, adequate safety measures including but not limited to fail-safe design against the physical injury, damage to any property, which a failure or malfunction of our Products may cause. The following are examples of safety measures:
 - [a] Installation of protection circuits or other protective devices to improve system safety
 - [b] Installation of redundant circuits to reduce the impact of single or multiple circuit failure
3. Our Products are not designed under any special or extraordinary environments or conditions, as exemplified below. Accordingly, ROHM shall not be in any way responsible or liable for any damages, expenses or losses arising from the use of any ROHM's Products under any special or extraordinary environments or conditions. If you intend to use our Products under any special or extraordinary environments or conditions (as exemplified below), your independent verification and confirmation of product performance, reliability, etc. prior to use, must be necessary:
 - [a] Use of our Products in any types of liquid, including water, oils, chemicals, and organic solvents
 - [b] Use of our Products outdoors or in places where the Products are exposed to direct sunlight or dust
 - [c] Use of our Products in places where the Products are exposed to sea wind or corrosive gases, including Cl₂, H₂S, NH₃, SO₂, and NO₂
 - [d] Use of our Products in places where the Products are exposed to static electricity or electromagnetic waves
 - [e] Use of our Products in proximity to heat-producing components, plastic cords, or other flammable items
 - [f] Sealing or coating our Products with resin or other coating materials
 - [g] Use of our Products without cleaning residue of flux (Exclude cases where no-clean type fluxes is used. However, recommend sufficiently about the residue.); or Washing our Products by using water or water-soluble cleaning agents for cleaning residue after soldering
 - [h] Use of the Products in places subject to dew condensation
4. The Products are not subject to radiation-proof design.
5. Please verify and confirm characteristics of the final or mounted products in using the Products.
6. In particular, if a transient load (a large amount of load applied in a short period of time, such as pulse, is applied, confirmation of performance characteristics after on-board mounting is strongly recommended. Avoid applying power exceeding normal rated power; exceeding the power rating under steady-state loading condition may negatively affect product performance and reliability.
7. De-rate Power Dissipation depending on ambient temperature. When used in sealed area, confirm that it is the use in the range that does not exceed the maximum junction temperature.
8. Confirm that operation temperature is within the specified range described in the product specification.
9. ROHM shall not be in any way responsible or liable for failure induced under deviant condition from what is defined in this document.

Precaution for Mounting / Circuit board design

1. When a highly active halogenous (chlorine, bromine, etc.) flux is used, the residue of flux may negatively affect product performance and reliability.
2. In principle, the reflow soldering method must be used on a surface-mount products, the flow soldering method must be used on a through hole mount products. If the flow soldering method is preferred on a surface-mount products, please consult with the ROHM representative in advance.

For details, please refer to ROHM Mounting specification

Precautions Regarding Application Examples and External Circuits

1. If change is made to the constant of an external circuit, please allow a sufficient margin considering variations of the characteristics of the Products and external components, including transient characteristics, as well as static characteristics.
2. You agree that application notes, reference designs, and associated data and information contained in this document are presented only as guidance for Products use. Therefore, in case you use such information, you are solely responsible for it and you must exercise your own independent verification and judgment in the use of such information contained in this document. ROHM shall not be in any way responsible or liable for any damages, expenses or losses incurred by you or third parties arising from the use of such information.

Precaution for Electrostatic

This Product is electrostatic sensitive product, which may be damaged due to electrostatic discharge. Please take proper caution in your manufacturing process and storage so that voltage exceeding the Products maximum rating will not be applied to Products. Please take special care under dry condition (e.g. Grounding of human body / equipment / solder iron, isolation from charged objects, setting of ionizer, friction prevention and temperature / humidity control).

Precaution for Storage / Transportation

1. Product performance and soldered connections may deteriorate if the Products are stored in the places where:
 - [a] the Products are exposed to sea winds or corrosive gases, including Cl₂, H₂S, NH₃, SO₂, and NO₂
 - [b] the temperature or humidity exceeds those recommended by ROHM
 - [c] the Products are exposed to direct sunshine or condensation
 - [d] the Products are exposed to high Electrostatic
2. Even under ROHM recommended storage condition, solderability of products out of recommended storage time period may be degraded. It is strongly recommended to confirm solderability before using Products of which storage time is exceeding the recommended storage time period.
3. Store / transport cartons in the correct direction, which is indicated on a carton with a symbol. Otherwise bent leads may occur due to excessive stress applied when dropping of a carton.
4. Use Products within the specified time after opening a humidity barrier bag. Baking is required before using Products of which storage time is exceeding the recommended storage time period.

Precaution for Product Label

A two-dimensional barcode printed on ROHM Products label is for ROHM's internal use only.

Precaution for Disposition

When disposing Products please dispose them properly using an authorized industry waste company.

Precaution for Foreign Exchange and Foreign Trade act

Since concerned goods might be fallen under listed items of export control prescribed by Foreign exchange and Foreign trade act, please consult with ROHM in case of export.

Precaution Regarding Intellectual Property Rights

1. All information and data including but not limited to application example contained in this document is for reference only. ROHM does not warrant that foregoing information or data will not infringe any intellectual property rights or any other rights of any third party regarding such information or data.
2. ROHM shall not have any obligations where the claims, actions or demands arising from the combination of the Products with other articles such as components, circuits, systems or external equipment (including software).
3. No license, expressly or implied, is granted hereby under any intellectual property rights or other rights of ROHM or any third parties with respect to the Products or the information contained in this document. Provided, however, that ROHM will not assert its intellectual property rights or other rights against you or your customers to the extent necessary to manufacture or sell products containing the Products, subject to the terms and conditions herein.

Other Precaution

1. This document may not be reprinted or reproduced, in whole or in part, without prior written consent of ROHM.
2. The Products may not be disassembled, converted, modified, reproduced or otherwise changed without prior written consent of ROHM.
3. In no event shall you use in any way whatsoever the Products and the related technical information contained in the Products or this document for any military purposes, including but not limited to, the development of mass-destruction weapons.
4. The proper names of companies or products described in this document are trademarks or registered trademarks of ROHM, its affiliated companies or third parties.

General Precaution

1. Before you use our Products, you are requested to carefully read this document and fully understand its contents. ROHM shall not be in any way responsible or liable for failure, malfunction or accident arising from the use of any ROHM's Products against warning, caution or note contained in this document.
2. All information contained in this document is current as of the issuing date and subject to change without any prior notice. Before purchasing or using ROHM's Products, please confirm the latest information with a ROHM sales representative.
3. The information contained in this document is provided on an "as is" basis and ROHM does not warrant that all information contained in this document is accurate and/or error-free. ROHM shall not be in any way responsible or liable for any damages, expenses or losses incurred by you or third parties resulting from inaccuracy or errors of or concerning such information.