

- △ USE CRIMP TOOL: 354940-1
- 2. PANEL THICKNESS = 5.08 [.200] MAX
- 3. USE INSTRUCTION SHEET 408-4048
- 4. CAPACITANCE = 9400 PF ± 10% TOTAL
VOLTAGE = 500 VDC

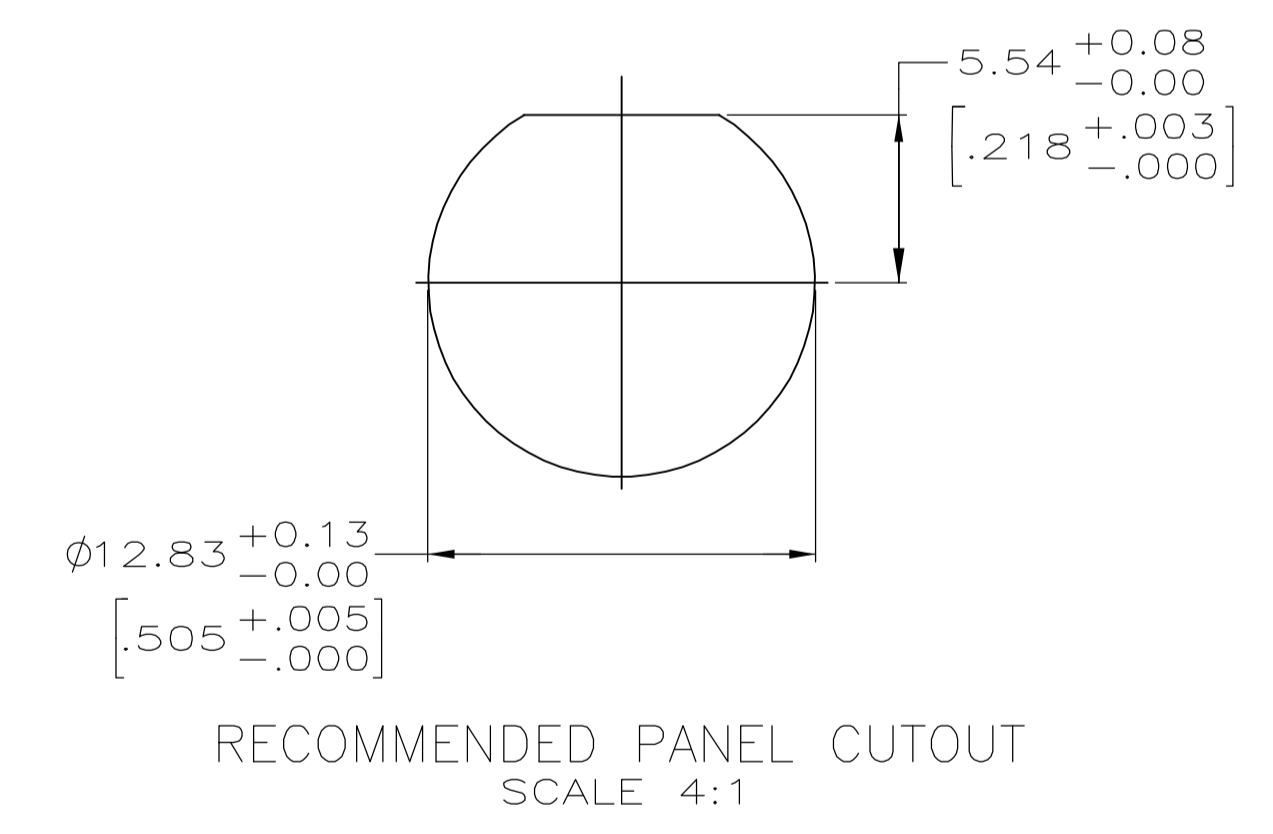
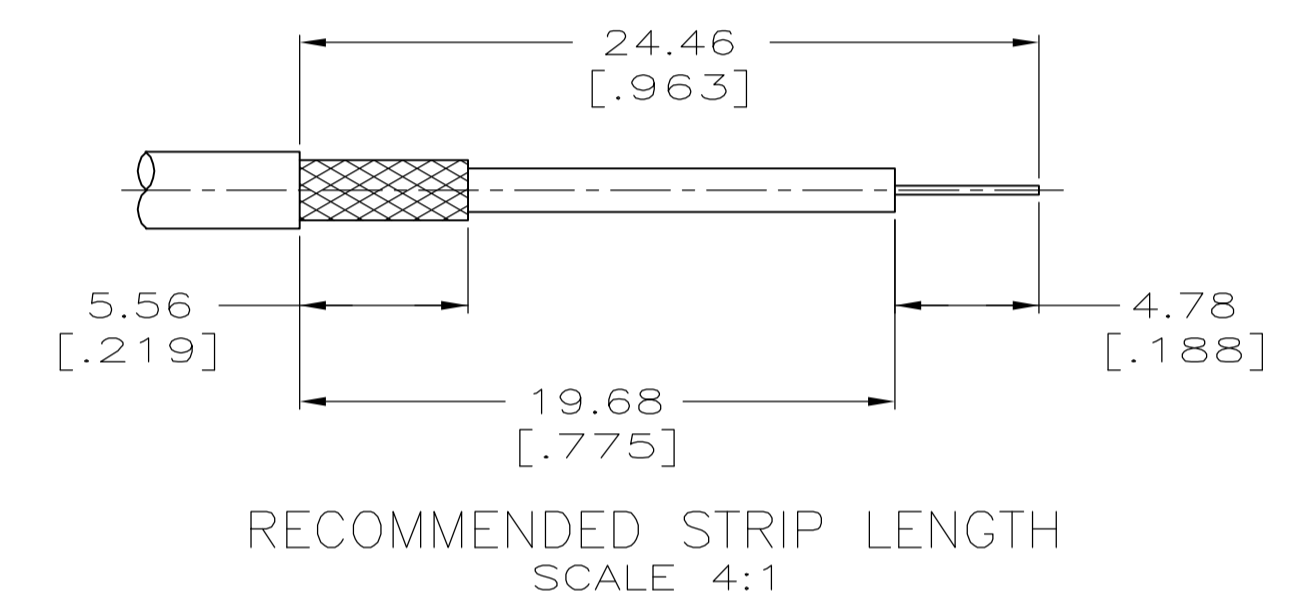
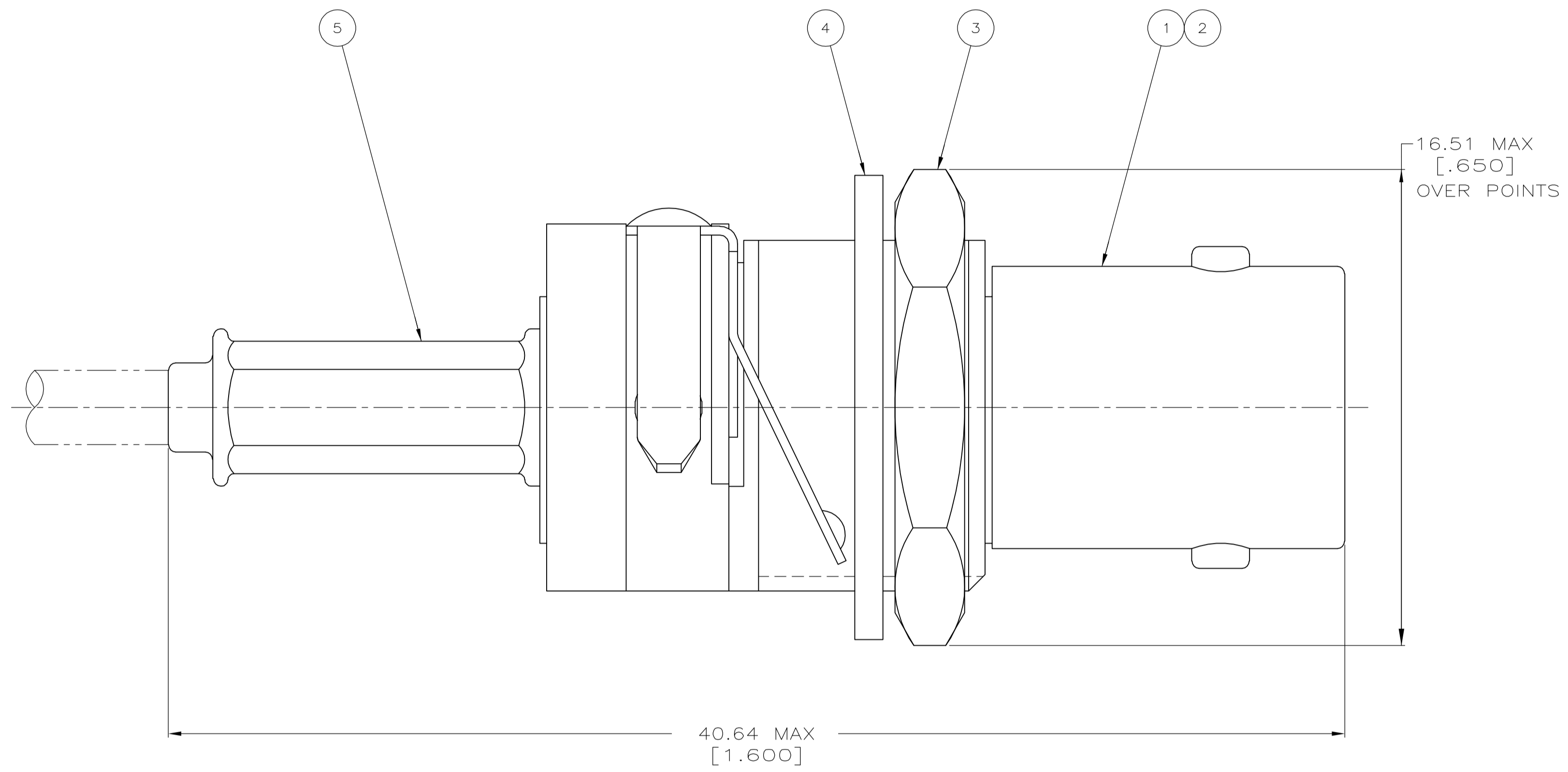

	RG-174/U, 188/U, 316/U	4.52 [.178]	1.73 [.068]	58436-3	227194-5	9-413658-0	1-329632-2	1-329631-2	1-413774-5	414757-2	414758-2
OBSOLETE	RG-58/U, 58A/U, 58B/U, 58C/U	5.41 [.213]	1.73 [.068]	58436-1	-	9-221132-0	1-329632-2	1-329631-2	413774-5	414757-1	414758-1
	FOR USE WITH CABLE	FERRULE	CENTER CONTACT	DIE SET △	⑥ SPACER QTY=1	⑤ FERRULE QTY=1	④ LOCK WASHER QTY=1	③ JAM NUT QTY=1	② CONTACT QTY=1	① JACK ASSEMBLY QTY=1	PART NUMBER
		HEX CRIMP HEIGHTS									

THIS DRAWING IS A CONTROLLED DOCUMENT.

DIMENSIONS: INCHES	TOLERANCES UNLESS OTHERWISE SPECIFIED:	DWG: M. E. COWHER 14APR94	CHK: M. PHILLIPS 14APR94	APVD: M. PHILLIPS 15APR94	NAME: JACK, BULKHEAD, DECOUPLER, 50 OHM, HEX CRIMP, BNC
0 PLC ± -	1 PLC ± -	2 PLC ± 0.41 [.016]	3 PLC ± -	4 PLC ± -	ANGLES ± -
MATERIAL: -	FINISH: -	WEIGHT: -	SIZE: A1	SCALE: 8:1	SHEET: 1 OF 1

Customer Drawing: 00779C=414758