

## ***bq77908EVM Evaluation Module***

The bq77908EVM-001 evaluation module (EVM) is a complete evaluation system for the bq77908, a four-to eight-cell Li-ion battery protection integrated circuit. The EVM consists of a bq77908 circuit module and a resistor cell simulator module, which can be used for simple evaluation of the bq77908 functions. The circuit module includes one bq77908 integrated circuit (IC), sense resistor, power FETs and all other onboard components necessary to protect the cells from overcharge, overdischarge, short circuit, and overcurrent discharge in a 8-series cell Li-ion or Li-polymer battery pack. The circuit module connects directly across the cells in a battery. With a compatible interface board and Windows™-based PC software, the user can view the bq77908 registers and program the IC configuration and protection limits.

### Contents

1	Features .....	3
	1.1 Kit Contents .....	3
	1.2 Required Equipment .....	3
2	bq77908 Circuit Module and Interfaces .....	3
	2.1 Circuit Module Connections .....	3
	2.2 Signal Descriptions .....	4
3	bq77908EVM Hardware Connection and Operation .....	5
	3.1 Initial Considerations .....	5
	3.2 Connecting the Cell Simulator .....	6
	3.3 Simulated Battery Connection .....	6
	3.4 Pack Connections .....	6
	3.5 Basic Operation .....	8
	3.6 Cell Connections .....	8
4	Software Installation .....	9
	4.1 System Requirements .....	9
	4.2 Interface Adapter .....	9
	4.3 Install bq77910GUI Evaluation Software .....	11
5	Software Operation .....	11
	5.1 Menu commands .....	12
	5.2 Working With Register Values .....	15
	5.3 Status Section .....	16
	5.4 Basic Operation With Software .....	17
	5.5 Operation With Other Interfaces or Hosts .....	17
6	Related Documents From Texas Instruments .....	18
7	bq77908EVM Circuit Description and Configuration .....	18
	7.1 Battery Voltage Clamp .....	18
	7.2 Device Power .....	18
	7.3 Cell Monitor Inputs and Configuration .....	18
	7.4 Ground Connection .....	20
	7.5 Current Sense Connections .....	20
	7.6 Filter Capacitors .....	20
	7.7 FET Circuits .....	21
	7.8 Detection Sensing .....	21
	7.9 Output Protection Components .....	21
	7.10 Reserved Pins .....	22

Windows, Microsoft are trademarks of Microsoft Corporation.  
 Total Phase, Aardvark are trademarks of Total Phase, Inc.

7.11	Flag Outputs .....	22
7.12	Thermal Sensor .....	22
7.13	ZEDE .....	22
7.14	Programming Interface .....	22
8	bq77908 Circuit Module Physical Construction .....	23
8.1	Main Board .....	23
8.2	Resistor Cell Simulator .....	32

### List of Figures

1	Basic EVM Setup .....	8
2	Successfully Updated TI USB Interface Adapter .....	10
3	EVM Connection for Communication and Programming .....	11
4	GUI With Communication Established .....	12
5	Communication Selection Window .....	13
6	Commands Without Communication Established .....	13
7	Register Section .....	14
8	Status Section .....	16
9	Polling Status With Undervoltage Condition .....	17
10	Top Silk Screen .....	23
11	Top Assembly .....	24
12	Top Layer .....	24
13	Layer 2 .....	25
14	Layer 3 .....	25
15	Bottom Layer .....	26
16	Bottom Silk Screen .....	26
17	Bottom Assembly .....	27
18	Schematic Diagram, Sheet 1 of 2 .....	30
19	Schematic Diagram, Sheet 2 of 2 .....	31
20	Resistor Simulator Top Silk Screen .....	32
21	Resistor Simulator Top Layer .....	33
22	Resistor Simulator Bottom Layer .....	34
23	Resistor Simulator Top Assembly .....	35
24	Resistor Simulator Bottom assembly .....	36
25	Resistor Simulator Schematic Diagram .....	38

### List of Tables

1	Ordering Information .....	3
2	Cell Connections .....	4
3	PACK Connections .....	4
4	Programming Interface Connections .....	5
5	Test Header Signals .....	5
6	Control and Status Connections .....	5
7	Adapter Cable Pinout .....	10
8	Status Section Indicator Colors .....	16
9	Cell Count Component Configuration .....	19
10	bq77908 Circuit Module Bill of Materials .....	27
11	Performance Specification Summary .....	32
12	Resistor Simulator Bill of Materials .....	36

## 1 Features

- Complete evaluation system for the bq77908 4-to-8 series cell Li-ion or Li-polymer battery protector
- Populated circuit module for 8-cell, parallel FET configuration for quick setup
  - Pads for components for configuration of additional cell counts and series FETs
- Power connections available on terminal blocks or banana jacks
- Control and status signals available on terminal blocks
- Resistor cell simulator for quick setup with only a power supply
- Personal computer software available for configuration

### 1.1 Kit Contents

- bq77908 circuit module
- Resistor cell simulator
- Set of support documentation

**Table 1. Ordering Information**

EVM Part Number	Chemistry	Configuration	Capacity
bq77908EVM-001	Li-ion	8 cells	Any

**NOTE:** Although capacity [Table 1](#) is show as Any, practical limits of the physical construction of the module typically limit the operation of the EVM to a 1P or 2P battery construction. See [Section 8](#) for board details.

### 1.2 Required Equipment

The following equipment is required to operate the bq77908EVM in a simple demonstration.

- DC power supply, 0-V to 34-V at 0.5 A
- DC voltmeter or oscilloscope,
- DC power supply, ~3 V at .1 A or an approximately 15-k $\Omega$ , 1/4-W resistor
- Test leads to connect equipment

The following equipment is required to operate the bq77908EVM with a more extensive demonstration.

- TI USB-TO-GPIO interface adapter
- Computer with USB port and compatible Windows 32-bit operating system
- Electronic load
- Additional power supplies
- TI bq77910GUI Evaluation Software - see [Section 4](#).

## 2 bq77908 Circuit Module and Interfaces

The bq77908 circuit module contains the bq77908 IC and related circuitry to demonstrate the features of the IC. A FET with heatsink is provided for the high-current discharge path. A lower current FET is provided for the charge path. A thermistor provides temperature sensing for the device. Other components provide support for the IC and connections to the board.

### 2.1 Circuit Module Connections

Connections are provided for the following interfaces:

- Direct cell connections
- PACK connections
- Programming interface

## 2.2 Signal Descriptions

Signals available on the EVM are described in this section. For details on the location and connector types, see [Section 8](#). High current signals can be connected at either the terminal block or banana jack. Refer to the physical construction section for identification.

Cell connections are described in [Table 2](#). The default board assembly supports only 5 cells, so the upper cell connections are not used. CELL0 and CELL5 are connected to the high current paths on the board through 0-Ω resistors. This allows operation of the resistive cell simulator without external connections. If the onboard resistors are removed, connections must be made off the board. See [Section 8](#) for resistor identification. Cell connection sequence is described in [Section 3.6](#).

**Table 2. Cell Connections**

Reference Designator	Pin Number	Signal	Description
J13, J15	All	BATT-	Negative electrode of first (bottom) cell, high-current connection
J5	6	CELL0	Negative electrode of first (bottom) cell, optional separate monitor connection to cell
	5	CELL1	Positive electrode of first (bottom) cell
	4	CELL2	Positive electrode of second cell
	3	CELL3	Positive electrode of third cell
	2	CELL4	Positive electrode of fourth cell
	1	CELL5	Positive electrode of fifth cell,
J4	5	CELL6	Positive electrode of sixth cell
	4	CELL7	Positive electrode of seventh cell
	3	CELL8	Positive electrode of eighth cell, optional separate monitor connection to cell
	2	NC9	Unused connection
	1	NC10	Unused connection
J10, J11	All	PACK+	Most positive cell output, high-current connection, shared with PACK+

Load connections are described in [Table 3](#).

**Table 3. PACK Connections**

Reference Designator	Pin Number	Signal	Description
J10, J11	All	PACK+	Positive output of evaluation board, shared with the battery high-current connection
J12, J14	All	DSG-	Negative output of evaluation board for discharge
J16, J17	All	CHG-	Negative input to evaluation board for charge

Programming signals are described in [Table 4](#). J3 signals are 3.3-V logic level.

**Table 4. Programming Interface Connections**

Reference Designator	Pin Number	Signal	Description
J3	1, 2, 5, 7, 8		Not used
	3	PGM	Control signal for EEPROM programming voltage.
	4	ZD	Control signal for device ZEDE
	6	GND	Signal reference for the IC
	9	ECLK	Serial interface clock connection
	10	EDATA	Serial interface data connection
J2	1	14V	Regulated 14-V input for IC programming
	2	GND	Signal reference for the IC

Test header or pattern signals are described in [Table 5](#).

**Table 5. Test Header Signals**

Reference Designator	Usage	Pin Number	Signal	Description
J1	Default: shunt installed for normal operation. Remove shunt for U1 supply current measurement	1	Battery feed	Power feed to 100-Ω shunt resistor
		2	BAT	Output of 100-Ω shunt resistor to IC BAT pin
J6	Default: no shunt. Install shunt to hold ZEDE high	1	VREG	IC regulator output
		2	ZEDE	IC zero delay test point and input pin, also connected to J3
		3	PD	Pulldown resistor for strong pulldown of ZEDE if required
J8	Not populated. Alternate test point or remote thermistor connection	1	TS	IC temperature sense pin
		2	GND	Signal reference for the IC

Control and status signals are provided on terminal blocks. These signals are described in [Table 6](#).

**Table 6. Control and Status Connections**

Reference Designator	Pin Number	Signal	Description
J7	1	TS	IC TS signal through a resistor
	2	GND	Signal reference for the IC
J9	1	CHGCTL	Control signal for charger detection, connects through a resistor to the IC CHGST pin
	2	DSGFLAG	Diode and resistor isolated DSG signal
	3	CHGFLAG	Diode and resistor isolated CHG signal

### 3 bq77908EVM Hardware Connection and Operation

This section describes the connection of the circuit module and EVM and simple operation in its default configuration.

#### 3.1 Initial Considerations

Boards are tested after assembly with a basic functional test. This test may not check every connection on the board. Boards must be checked for function in the user's environment before relying on the safety features of the board. Operation of the board with test equipment before connecting cells is recommended and described in this document.

The default configuration of the board is 8 cells with parallel FETs. Modifying the EVM for different cell counts or FET configuration requires solder connections. It is recommended that the users familiarize themselves with operation of the board in the default configuration before modifying the board, and check the operation of the board with test equipment after any modification. Configuration of the board is described in [Section 7](#).

Be sure to observe the cautions and warnings in this document.

A variety of connections are provided on the EVM. The manufacturer's rating for the terminal blocks for Pack and Battery connections is 32 A nominal. Parallel connections are provided for high-current operation. The banana jacks are rated at 15 A. Safety agency ratings may be lower than the manufacturer ratings; limit currents to appropriate values for your evaluation. Cell monitor terminal blocks and the control signal terminal blocks are rated at lower currents and must not be used for high-current paths.

A communication interface is not required for basic operation; it must be connected to the computer and EVM circuit module only after proper installation of software. The software along with an appropriate communication interface allows setting the programmable safety limits of the device and checking the status after fault detection. Installation of the software and its use are described in [Section 4](#) and [Section 5](#), respectively.

### 3.2 **Connecting the Cell Simulator**

The cell simulator consists of headers to mate the board and ten 200- $\Omega$  resistors to divide the battery voltage between the inputs. Only 8 of these resistors are used for the bq77908 EVM. Power is provided through the Cell0 and Cell8 connections on the terminal block headers. Various test points are provided on the board. See [Section 8](#) for additional details.

- Be certain no power is applied to the board.
- Unplug the screw terminal blocks from J4 and J5 of the EVM, and save these for later use.
- Plug the cell simulator board onto J4 and J5. Support may be required on the bottom of the EVM while the connectors are pressed together firmly.

#### **CAUTION**

Do not connect or remove the cell simulator board while power is applied to the EVM. The resistor pulldown or pullup from intermittent connections overstresses the device inputs.

### 3.3 **Simulated Battery Connection**

Connect a power supply between BATT- (negative) and PACK+ (positive). This power supply connects to the resistor cell simulator through default connections on the bq77908 circuit module.

### 3.4 **Pack Connections**

A load or charger is connected to the pack terminals using the terminal blocks provided. It is recommended that the load or charger be connected with the current switched off to prevent arcing or transients during connection of the wires to the terminal blocks. Charger detection is required for the bq77908 with a signal at the CHGST pin. Charger detection can be provided by connecting a resistor from the CHGCTL terminal of the board to the PACK supply, or with a logic level voltage supply for evaluation. An external resistor is required due to the low resistance pulldown on the board. The selected resistor must keep the CHGST voltage above the VCHG\_DET1 data sheet threshold over the entire evaluation voltage range while limiting the power in the 1-k $\Omega$  pulldown resistor to 1/16 W or less. A 15-k $\Omega$ , 1/4-W resistor is typically suitable for the default configuration; a smaller value may be required for low voltage or if the configuration is changed.

**WARNING**

**The CHGCTL must not be tied to the power supply without the external resistor because the 1-k $\Omega$  resistor on the board becomes very hot and may damage the board.**

Although designed for 30-A operation, the board may not dissipate enough power to operate without exceeding all component ratings. The user must monitor the temperature of the board and components during evaluation and provide cooling air and/or heatsinks as required for operation. The thermal sensor on the board may not respond to protect the FETs from damaging temperatures due to its location and possible thermal gradients on the board.

**CAUTION**

The bq77908 circuit module may be damaged by overtemperature. To avoid damage, monitor the temperature during evaluation, and provide cooling as needed for your system environment.

**WARNING**

**The bq77908 circuit module may become hot during operation due to dissipation of heat. Avoid contact with the board. Follow all applicable safety procedures applicable to your laboratory.**

**CAUTION**

Some power supplies can be damaged by application of external voltages. If using more than one power supply, check your equipment requirements, and use blocking diodes or other isolation techniques as needed to prevent damage to your equipment.

The connection of the EVM looks similar to [Figure 1](#).

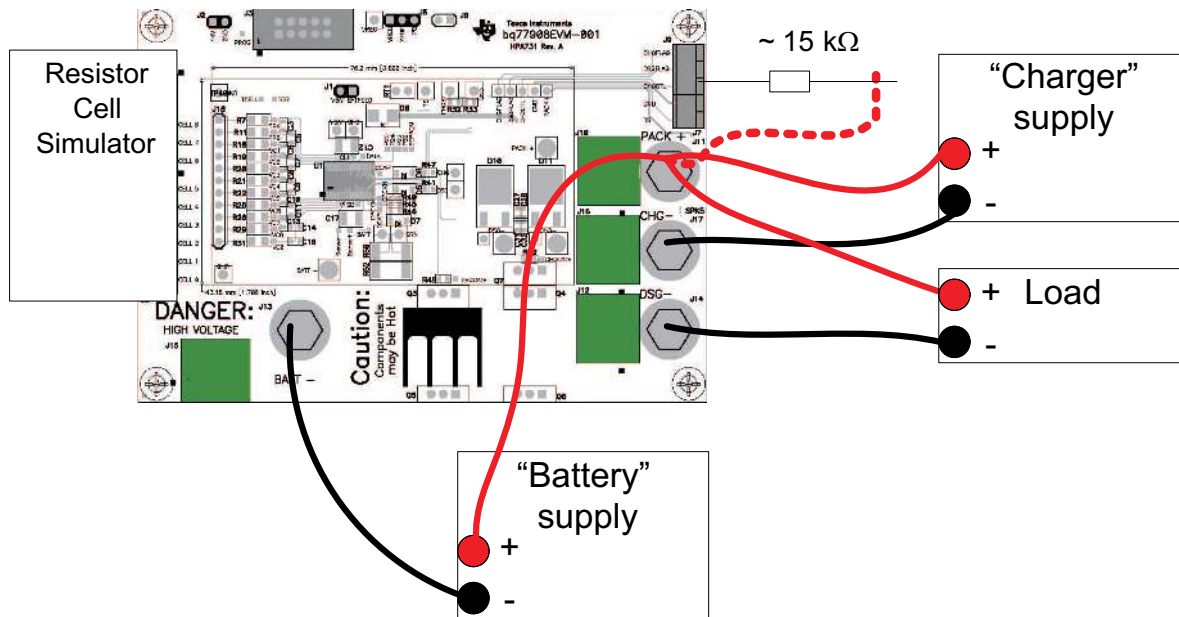
**Figure 1. Basic EVM Setup**

### 3.5 Basic Operation

The following steps are suggested for basic operation of a default EVM with the cell simulator and the default configuration in EEPROM.

1. Confirm that the cell simulator board is installed on the EVM.
2. Connect a power supply between the BATT- (negative) and PACK+ (positive) terminals.
3. Connect a 15-k $\Omega$ , 1/4-W resistor to the CHGCTL terminal of the board.
4. Set the bench supply to approximately 29 V.
5. Connect a disabled load between the DSG- (negative) and PACK+ (positive) terminals.
6. Wake up the part by momentarily connecting the 15-k $\Omega$  resistor to the bench supply positive.
7. Monitor the CHG and DSG test points using a meter or oscilloscope as desired.
8. Enable the load with a nominal 0.2-A or other current within the capability of the supply.
9. Increase the bench supply voltage to approximately 34 V, and observe that the CHG output goes low.
10. Reduce the voltage to approximately 29 V, and observe that the CHG output returns high.
11. Decrease the voltage to approximately 20 V, and observe that the DSG output goes low and the load current drops. The device shuts down after 9 seconds at low voltage.
12. Remove the load, and connect the CHGCTL resistor to the supply to simulate a charger.
13. Increase the supply voltage to approximately 29 V, and observe that the DSG test point goes high, and if the load is re-connected, that current flows again.

### 3.6 Cell Connections

For initial evaluation, it is suggested power supplies be used for cell simulation to observe the behavior of the device. An isolated power supply with a resistor connected across its terminals may be connected to test points on the resistor simulator to vary the voltage above or below the voltage of the other cells, or a similar configuration may be used. The smaller the resistor value, the more current is required from the battery simulator power supply and the smaller the influence on the voltages if cell balancing is operated.

Whether power supplies or cells are used, inductance in the high-current path must be minimized. Inductance in this path can cause inductive transients at the board when the load current is stopped or the bq77908 opens the discharge FET with current flow. Use heavy-gauge wires for the high-current connections; minimize inductances by keeping leads close together.



When connecting cells to the EVM, the user must use care not to exceed the absolute maximum ratings of the device. The bq77908 is designed with open-cell (wire) detection; however, fixturing must not pull unconnected signals up or down. Signal reference (VSS) for the part is from the BATT- terminal of the EVM, and this lowest potential must be connected first. Cells must be connected in sequence from lowest to highest voltage as described in the data sheet. When terminating the cells to the removable terminal blocks prior to connection to the EVM, the following steps are recommended:

1. Be sure the charger and any load is disconnected (CHGCTL is open).
2. Connect the cell stack negative high-current terminal to the EVM BATT- terminal.
3. Connect the lower cell group to the J5 connector.
4. Connect the upper cell group to the J4 connector.
5. Connect the cell stack positive high-current terminal to the EVM PACK+ terminal.
6. When removing cells, remove any charger and CHGCTL connection, then disconnect in the reverse order.

## 4 Software Installation

This section describes how to install the software for the bq77908EVM-001.

The bq77908 uses the same evaluation software as the bq77910.

### 4.1 System Requirements

The bq77908 evaluation software requires a 32-bit version of Windows™ XP, Windows Vista, or Windows 7. The computer must also have Microsoft™ .NET framework version 2.0 or higher installed. Examples in this document are from Windows XP.

### 4.2 Interface Adapter

The bq77908 evaluation software supports either the TI USB-TO-GPIO adapter (TI USB Interface Adapter) or the Total Phase™ Aardvark™ to provide communication with the EVM board from the computer. The Total Phase Aardvark must be selected if desired. The EVM connector supports the TI USB Interface Adapter; a special cable must be constructed if you wish to use the Aardvark.

#### 4.2.1 TI USB Interface Adapter

The TI USB Interface Adapter is the default option for the bq77908 evaluation software. Its pinout is compatible with the bq77908EVM board J3 connector.

The TI USB Interface Adapter <http://focus.ti.com/docs/toolsw/folders/print/usb-to-gpio.html> is actually a separate EVM from Texas Instruments, and its default firmware is not compatible with the bq77908. If the firmware has already been updated to version 2.0.19 to work with other BMS-HCE products, additional update is not required. If required, update the firmware using the following steps.

1. Obtain the USB-to-GPIO EVM Firmware Loader from <http://focus.ti.com/docs/toolsw/folders/print/usb2gpio-loader-sw.html>, or search from [power.ti.com](http://power.ti.com)
2. Download, extract, and run the installer
3. Installation requires the Microsoft .NET connection software. If a suitable version is not found on the system by the installer, the user is prompted to obtain and install .NET.
4. Connect the TI USB Interface Adapter to the computer with the USB cable. The green LED illuminates.
5. Run the program, typically from Start → Run → Texas Instruments → USB-TO-GPIO Firmware Loader.
6. Detailed instructions are provided in the Readme.txt file.

#### CAUTION

Do not disconnect the USB cable to the Interface Adapter during firmware update. Loss of power may leave the adapter with corrupt firmware and be unable to further update the firmware.

7. If you want to be able to return to the original configuration, back up the installed firmware before update.
8. Load and update to the 2.0.19 version using the instructions provided.
9. If an error occurs, do not unplug the adapter. Re-try loading, load a different firmware, or re-start the software and repeat until a load is successful.
10. After successful update, the window appears as is shown in [Figure 2](#)
11. After update, exit the program.



**Figure 2. Successfully Updated TI USB Interface Adapter**

#### 4.2.2 Aardvark Adapter

Although the Total Phase Aardvark adapter can physically mate to the EVM J3 connector, the pinout is incompatible. A special interface cable must be constructed to use the Aardvark. Refer to the schematics and [Table 7](#) below for information.

#### CAUTION

Do not connect the Aardvark to the EVM without a properly constructed cable. Damage may result to the EVM and/or Aardvark.

**Table 7. Adapter Cable Pinout**

IC Pin Name or Description	USB-TO-GPIO (Mates to J3)		Aardvark	
	Pin	Signal	Pin	Signal
VSS – signal reference	6	GND	2	GND
SCLK	9	SCL	1	SCL
SDATA	10	SDA	3	SDA
ZEDE - communication enable	4	GPIO4	5	MISO/GPIO
Programming voltage control signal for EEPROM	3	GPIO5	7	SCLK/GPIO

### 4.3 Install bq77910GUI Evaluation Software

The bq77908 uses the same evaluation software as the bq77910. Find the latest software version in the bq77910GUI Evaluation Software tool folder on <http://focus.ti.com/docs/toolsw/folders/print/bq77910gui-sw.html>, or search from [power.ti.com](http://power.ti.com). Check periodically for software updates. Use the following steps to install the bq77908 Evaluation Software:

1. Copy the archive file to a directory of your choice; extract and run the bq77910 Setup.msi installer.
2. Follow the instructions, and make selections as required on the setup windows, selecting next as required.
3. On the last window, select "close" to complete the bq77910 software installation.

## 5 Software Operation

This section describes connection of the communication interface to the EVM and operation of the software.

Although the software will run without connection to a powered device, it is recommended to have the device on when starting the software. Figure 3 shows connections for operation with the GUI software.

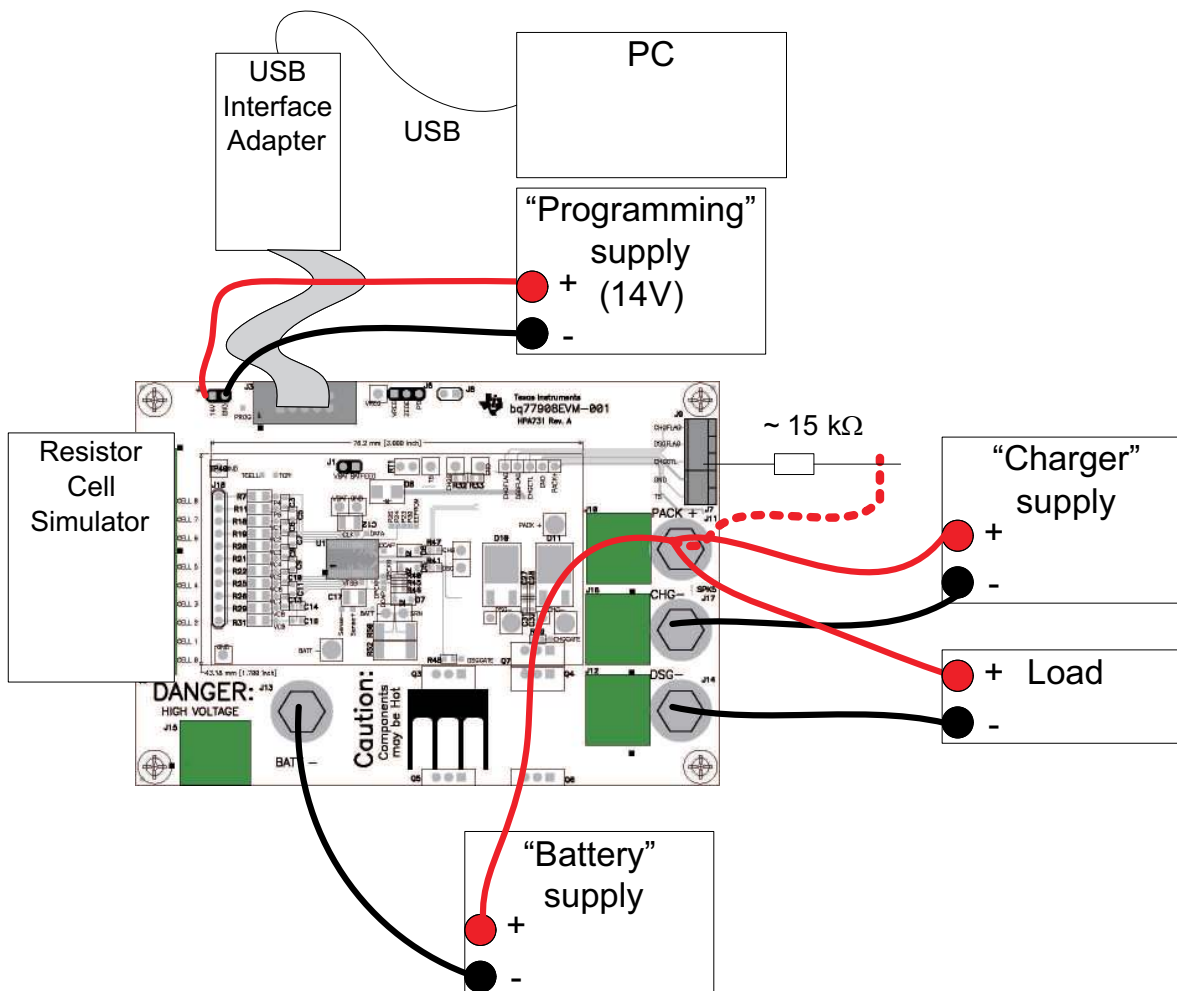

Figure 3. EVM Connection for Communication and Programming

To connect the computer to the GUI and start the software, use the following steps:

1. Connect the TI USB interface adapter to the computer.
2. Connect the 10-pin connector from the interface adapter to the EVM J3

**CAUTION**

The communication interface is not isolated on the EVM. Be sure no ground potential exists between the computer and the EVM. Also be aware that the computer is referenced to the battery-potential of the EVM.

3. Remove any shunt installed on J6 so that the interface can control ZEDE.
4. Connect the battery power supply to the EVM, and adjust to approximately 29 Vdc.
5. Wake the bq77908 by connecting CHGCTL high.
6. Start the software, typically using Start → All Programs → Texas Instruments → bq77908 Evaluation.

When started, the software looks for the communication interface and the device. When communication is established with the device, the main window appears as shown in [Figure 4](#). The software copies the EEPROM to the volatile registers.

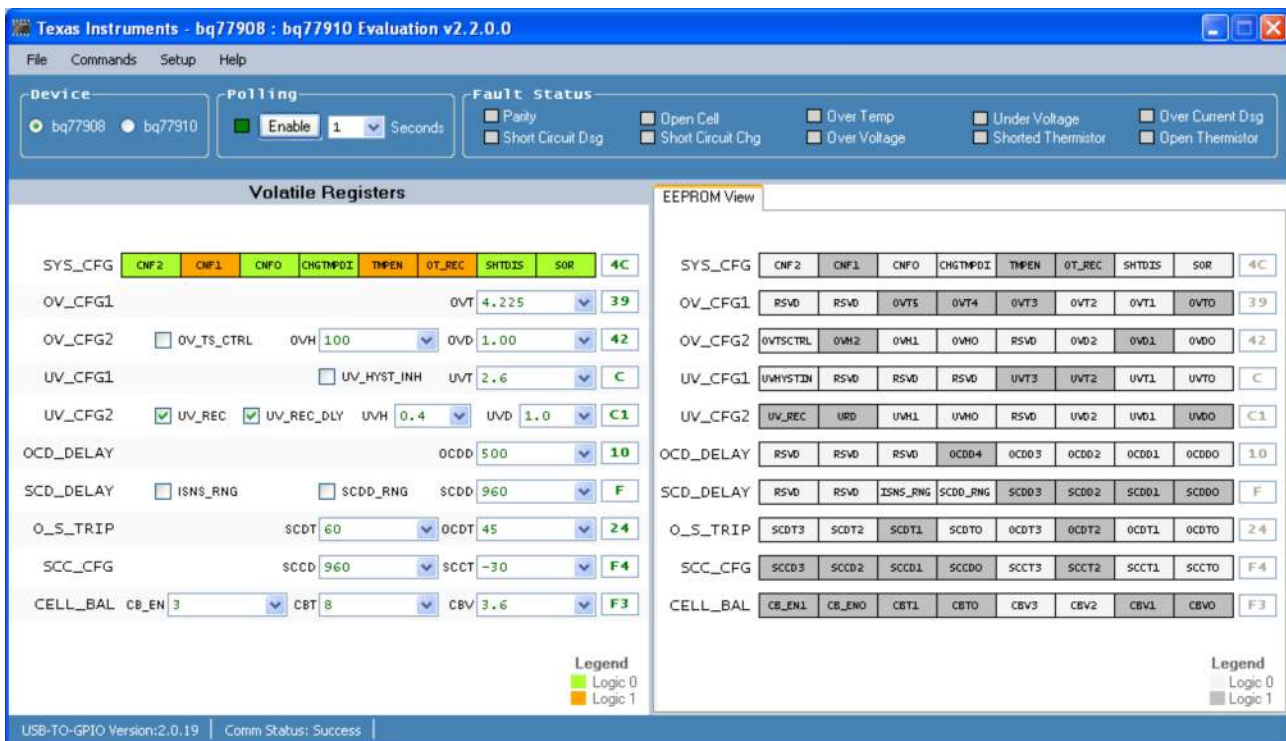

**Figure 4. GUI With Communication Established**

Other than the menu selections, the software window has three sections. In the bottom border is a status section. The middle section is a register section. The top section has a selection for the device used and a status area useful for checking the device status when a fault is detected. Details are described in following sections.

## 5.1 Menu commands

### 5.1.1 Help Menu

The Help → About menu selection displays version information about the program.

### 5.1.2 Setup Menu

The Setup → Communication selection allows selection of either the USB Interface Adapter or the Aardvark. Default is the TI USB Interface Adapter, and this window is not needed. Selecting the Save and Exit button checks for the adapter. If the selected adapter is not present, a communications error window appears. Selecting OK in the window returns to the Communication Selection window. To exit without having the selected adapter connected, use the close window tool (red X button). Selection of an adapter other than the two shown is not supported.



Figure 5. Communication Selection Window

### 5.1.3 Commands Menu

Most commands are only available after communication is established with the device. Figure 6 shows the command window when communication is not yet established.



Figure 6. Commands Without Communication Established

The communication status in the bottom border of the window shows the adapter in use and the device communication status. If the software is started and the adapter is not found, a Communication Error message box is displayed. Selecting OK on the box displays the main window. If the device is not recognized, a Device Not Found box is displayed. Selecting OK to this box also displays the main window. The communication fault is displayed in the status area of the window. Communication can be re-tried by selecting the menu command Commands → Find Target. Once communication is established with the part, the Find Target command is no longer available.

The other commands relate to the register section. The register section is shown in Figure 7. Two sets of registers are displayed: the right section can display the EEPROM settings, and the left side can display



the volatile registers waiting to be programmed in the EEPROM. When the software is first started, all values are shown as zero. When the software is started and connects to the device, it will copy the EEPROM values to the volatile registers. The software does not know if power has been removed from the part and will continue to display the values, even though the device may have different values. Registers should be read before use.

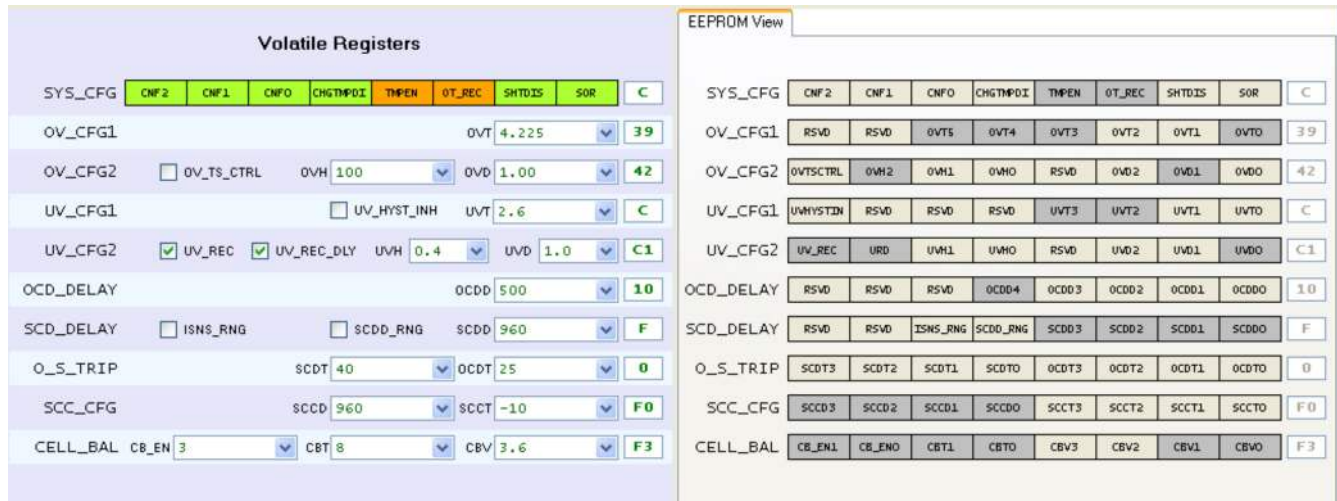

Figure 7. Register Section

The Read Volatile Registers command reads the values from the registers in the part and displays them in the GUI window. When a part is first powered, these are typically zero. When connecting to a powered part, they likely contain residual values.

The Read EEPROM Registers command reads the EEPROM values from the device and displays them in the EEPROM registers section of the window for viewing. This is a viewing operation, and data manipulation is not allowed in the displayed EEPROM data.

The Read All Registers command reads both the volatile and EEPROM registers from the device and displays the values.

The Copy EEPROM to Volatile command copies the EEPROM register values to the corresponding volatile registers and displays both in the GUI. This is a good starting point for making incremental changes to the device settings.

The Verify Volatile Registers command checks whether the volatile registers match the contents of the device. This can be useful as a check before programming the EEPROM.

The Program EEPROM command writes the volatile register values

### 5.1.4 File Menu

The Load Registers from File command reads a properly formatted file and fills the volatile register section with the values. This is useful for loading a device with a saved configuration. A windows navigation tool allows selection of the file. Whereas files can be edited, it is recommended to load files saved by the software, and if any editing is performed on the file, check all values before programming the device.

The Save Registers to File command creates a file. A windows navigation tool allows selection of the location and file name. Files have the .cfg extension.

The Exit command exits the program.

## 5.2 Working With Register Values

When the software initially connects to a device it will copy that device's EEPROM to its volatile registers and display those results. Since the device does not know if power has been lost to the device, the register display may be stale. If the device has been changed or power cycled to the part, the registers should always be read before making changes. If a file is loaded with values matching the displayed values, the software will not know the data is different from the part. Reading the registers or copying EEPROM values to the volatile registers is recommended before any change.

EEPROM values are displayed but are not directly editable in either the device or the GUI. Changes are made to a volatile register set by changing the volatile register value which is written to the volatile register in the device and later written to the device EEPROM by the programming process. Changes in the volatile registers do not affect operation of the device until written into the EEPROM.

The software does not know the difference between the bq77908 and bq77910. The user must select the device connected with the selection buttons in the top section of the window. Selecting the bq77908 will add some limit checking for the SYS\_CFG CNF field to avoid programming an invalid configuration into the device. Attempting to program an invalid configuration with the bq77908 selected will display an error box and will not program the part. The device selection also changes the device name in saved configuration files.

Values in the Volatile Registers section can be typically be changed in three ways:

- Loading a register file
- Changing a check box or drop-down selection
- Entering a data value in the box corresponding to the register name

The SYS\_CFG register bits are displayed as selection boxes; these are green for a value 0 and orange for a value 1.

The following steps describe changing a device EEPROM setting on the EVM using the GUI with a connected adapter:

1. Power the EVM (device) with the battery supply, and wake it up with charger detection.
2. Maintain a logic high on the CHGCTL pin of the EVM (CHGST device pin).
3. Copy the EEPROM values to the volatile registers with the Copy EEPROM to Volatile command.
4. Edit the values in the Volatile Registers section as desired.
5. Provide a 14 V  $\pm$ 0.5 V at approximately 0.1-A programming voltage at the EVM J2 connector.
6. Select the Program EEPROM command.
7. After a short delay, a programming complete status window appears. Select OK in this window.
8. Disconnect the programming voltage from the EVM J2 connector.

Programming the EEPROM from a file uses a similar sequence. This can be useful in evaluation when replacing a device or duplicating a design on a small number of boards. The following steps describe programming a device EEPROM on the EVM from a saved configuration file using the GUI with a connected adapter:

1. Power the EVM (device), and wake it up with charger detection.
2. Maintain a logic high on the CHGCTL pin of the EVM (CHGST device pin).
3. Copy the EEPROM values to the volatile registers with the Copy EEPROM to Volatile command if the software is not restarted for each device.
4. Select the File  $\rightarrow$  Load Register File command, navigate to, and open the desired file.
5. Provide a 14 V  $\pm$ 0.5 V at approximately 0.1-A programming voltage at the EVM J2 connector.
6. Select the Program EEPROM command.
7. After a short delay, a programming complete status window appears. Select OK in this window.
8. Disconnect the programming voltage from the EVM J2 connector.

After programming, it may be necessary to clear fault status because programming requires communication with the device and that requires setting ZEDE high. ZEDE high may make the part respond to noise. SCC is typically the lowest value threshold in the device and is common after programming or other communication with the part, depending on the device settings and operating environment.

**CAUTION**

Although the software may be useful for producing a small number of boards, it is not intended as a production programming tool. Accidental manipulation of the registers when the file is loaded and when the programming command is sent is not prohibited.

During programming, the software checks that the device volatile registers match the values shown. If they do not match, an error message is displayed. Continuing with programming when the values do not match will unexpectedly alter the configuration of the device. If the error is displayed, it is recommended to read the volatile registers to examine the contents, correct any communication error, and re-start the software or device as needed for proper programming.

### 5.3 Status Section

The status section of the GUI is shown in [Figure 8](#). This section allows the user to display internal status registers of the devices fault condition. This data is not part of normal operation of the device and is not shown in the data sheet. Accessing the data is disruptive to the device; however, it can be beneficial in evaluation.



**Figure 8. Status Section**

The status is read by selecting the Polling Enable button on the left side of the status section. This periodically sets ZEDE high to the device, reads the status registers, and returns ZEDE low. The polling period can be selected with the drop-down box next to the button. The button function and label change to Disable. The button label indicates the action of the next button actuation.

A consequence of polling is that a pending fault delay is terminated by the status read. Polling is typically independent of any system change, and a fault may be recorded as soon as the poll occurs. This may lead to unexpected results in evaluation. The following text describes a couple examples which can occur:

- The user has selected a 2-second undervoltage delay and wants to observe the timing on a scope. The user leaves polling active and decreases the device voltage. The poll occurs just after the voltage drops, and the zero delay causes the fault to be registered. The FETs turn off and the user thinks the delay setting is not working. This situation occurred because the poll set ZEDE high and terminated the undervoltage delay.
- The user is polling status to watch faults. CHGST is tied high to prevent the part from shutting down due to undervoltage. The user begins switching currents and is surprised when a SCC fault occurs. Observing the sense resistor voltage, the user does not see a charge current. This situation occurred because the poll set zero delay and eliminated noise filtering on the current. The SCCT is typically a low and thus most sensitive to any noise; having CHGST high prevents recovery from the fault.

The values display in several colors. See [Table 8](#).

**Table 8. Status Section Indicator Colors**

Color	Meaning
Gray	Status is not read
Bright green	Device is polling and status is normal with connected device, or adapter is not connected
Bright red	Device is polling and status is fault
Dark green or dark red	Device is not polling and value is residual from last poll



Figure 9 shows a typical status display polling with undervoltage.

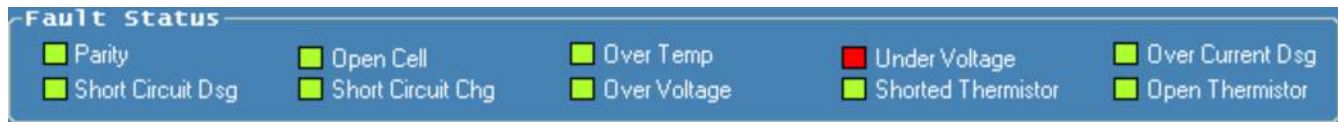

**Figure 9. Polling Status With Undervoltage Condition**

Another use of the status section is to determine the reason the part has turned off the FETs. For example, if during test the EVM has turned off the FETs but the VREG is still on, the interface might be connected and the status polled to see what fault the device identifies.

#### 5.4 Basic Operation With Software

The following steps are suggested for exercising more of the device features using the EVM in its default 8-cell configuration and EEPROM settings. The board is connected as shown in Figure 3. Remember that timing as described in Section 5.3 will be incorrect.

1. Install the software.
2. Connect the USB Interface Adapter to the computer with the USB cable.
3. Remove the screw terminal blocks from J4 and J5, and save for later use. Connect the cell simulator board to the bq77908 main board J4 and J5. Support the under side of the EVM board as the connectors are pressed together.

#### CAUTION

Do not connect or remove the resistive cell simulator from the board with power applied. The resistor pull-down or pull-up from intermittent connections overstresses the device inputs.

4. Connect the 10-pin ribbon cable from the USB Interface Adapter to the EVM J3.
5. Connect an isolated power supply negative to BATT- and positive to PACK+. Adjust the voltage to approximately 29 V.
6. Connect an approximate 15-k $\Omega$  resistor from the power supply positive to the CHGCTL terminal. This wakes up the part; leave the resistor connected.
7. Start the software.
8. Connect a disabled load to the pack terminals.
9. Select the Polling Enable button in the software window.
10. Observe that the status values are bright green.
11. Set a current on the load within the capability of the supply and board.
12. Decrease the power supply voltage to approximately 20 V. Observe that using the load current stops, and the UV status indicator turns red.
13. Increase the supply voltage to approximately 29 V. Observe that the UV indicator turns green.
14. Load current may not resume until the load is disabled or disconnected.
15. Increase the supply voltage to approximately 34 V. Observe that the OV status indicator turns red.
16. Decrease the power supply voltage to approximately 29 V. Observe that the OV indicator turns green.
17. Disable polling.
18. Disable the load
19. Set the supply to 0 V, and turn off equipment.

#### 5.5 Operation With Other Interfaces or Hosts

The bq77910 GUI software does not support other interfaces.

Communication with the bq77908 from other hosts must be straightforward. See to the data sheet for timing and interface details. On the EVM, zero delay mode can be set to allow communication using a 0.1-inch shunt (not provided) at J6 pins 1 to 2, or a signal at ZD on J3. To program, the onboard programming voltage switch can be used by controlling the PGM signal on J3. Signals must be 3.3-V CMOS levels.

## 6 Related Documents From Texas Instruments

To obtain a copy of any of the following TI document, call the Texas Instruments Literature Response Center at (800) 477-8924 or the Product Information Center (PIC) at (972) 644-5580. When ordering, identify this document by its title and literature number. Updated documents can also be obtained through the TI Web site at [www.ti.com](http://www.ti.com)

Document	Literature Number
bq77908 data sheet	<a href="#">SLUSAI5</a>

## 7 bq77908EVM Circuit Description and Configuration

This section describes the circuit on the bq77908 circuit module and how to configure it for changes the user may want to make to the board for specific evaluations. In many cases, an EVM schematic is used as a starting point for a circuit design. This can result in unnecessary extra components on the product design that take up space and add cost. Refer to the schematic in [Section 8](#) while reading the following descriptions. Note that the schematic has two pages: the first shows the main functions, and the second page shows primarily cell count configuration and protection components.

### 7.1 Battery Voltage Clamp

The TVS diode D9 provides a clamp for transients on the pack. A common transient is due to system inductances and sudden load shutoff. The breakdown voltage of D9 must be set near or below the 5-V per cell absolute maximum of the device. As a transient pushes the voltage up the I-V curve, a substantial device here reduces the demands on other clamping components in the system, which may be needed to protect the device. Alternatives to D9 may be to control the system inductance and current switching rate, use capacitance to absorb transients, or other transient protectors such as MOVs where appropriate.

### 7.2 Device Power

The device is powered through the BAT pin. C12 is a bypass capacitor near the IC; the footprint is large in order to make it easy to mount larger capacitors, in the event that this is desired in evaluation. R5 and J1 provide a way to measure current to the device during evaluation and are not needed in an application. D2 provides power from the battery to the IC and prevents the IC power from being pulled down when the battery voltage dips suddenly due to a heavy load on the battery. C2 provides an operating reservoir for device current during battery voltage droop. D1 limits the voltage to the BAT pin preventing overvoltage from rectification of transients by D2.

Power is provided through R4. The 200- $\Omega$  resistor provides for a voltage drop when an overvoltage charger pulls down BAT through D8. For lower cell counts, this resistor may be a smaller value. R3 is a 0- $\Omega$  connection to the high-current battery positive connection BATT+ which is shared with the PACK+. This jumper is provided in case the user wants to power the part from the current monitor line instead.

### 7.3 Cell Monitor Inputs and Configuration

The cell monitor inputs are provided through an RC filter network. The series resistors  $R_{VCX}$  connect the cells to the device to allow voltage measurement and limit the balancing current. Balancing current is approximately the cell voltage divided by twice the resistor. The EVM is circuit-designed to use the internal balancing path at near the maximum current. The 47- $\Omega$   $R_{VCX}$  value on the EVM is nominally within 10% of the 50- $\Omega$  minimum recommended in the data sheet and prevents exceeding the absolute maximum balancing current up to 4.3 V per cell. The input capacitance is typically connected between cell inputs, except the capacitances at VC8 and VC9 are connected to ground to avoid pushing the inputs below ground during transients. The capacitance must not be increased beyond the 1  $\mu$ F shown because the

capacitors are discharged into the device during balancing. The filter effect both reduces cell transients to the device inputs and slows voltage recovery after balancing. The resulting time constant is complicated due to the multiple components but relatively short due to the small resistors used for high balancing current. Due to the cell input voltage measurement after balancing, the time constant ( $R_{VCX}$ ) must not be made too large.

Note that two limits are implied by the absolute maximum cell-to-cell differential rating of the part. One is the applied differential voltage, or 5 V on any cell regardless of the other inputs. Note also that this is an applied voltage, not the voltage induced by the part during balancing, which may be higher. The second voltage limit is the voltage to ground the cumulative voltage from summing the individual limits. Because the input filter time constant is small, clamping the inputs to safe values may be required. While a Zener or TVS diode per cell may be a suitable way to protect the device in some applications, the EVM provides patterns D14 to D18 to clamp the inputs for cells 8 to 4 to ground. The top cell input is clamped (VC1 with D14 on the EVM), and cell 4's input, VC7, is clamped with D18 on the EVM because this input showed more sensitivity than others in testing. For nominal transients, these clamps along with the capacitors between cells hold the inputs to safe values; however, different or additional clamping may be required in evaluation or the target application.

The EVM has resistor jumper positions and is populated to connect to the cells with N+1 wires where N is the number of cells. R42 connects the high-current BATT- connection to the lowest cell monitor point. Similarly, R57 connects cell 8 input to the high-current path through R3. Additional resistor patterns R53 to R58 allow the same connections when the board is configured for other series cell counts. The board may be configured to monitor the cell voltages directly at the cells (N+3 wires) by removing R42 and R59 or the equivalent.

When configuring the part for fewer than 8 cells, the unused inputs must not be left floating and must be connected to avoid exceeding absolute maximums. The EVM provides patterns to allow flexible connections. The unused pin group may be connected together on the EVM by shorting the capacitors between them or shorting the appropriate resistor jumper positions R62 to R64. The unused pin group then needs to be connected to a safe level, either to the top cell through one of the unused cell  $R_{VCX}$  patterns or to the highest used VCx pin using the appropriate R63 to R65. When configuring for fewer than 8 cells and using the cell simulator, be sure to remove components to avoid parallel paths. Due to the flexibility allowed by the EVM for configuration, it is recommended evaluators study the schematic before modifying the board to achieve their desired configuration. Table 9 shows possible configurations for different cell counts assuming use of the cell simulator, retaining the N+1 wiring plan, and adjusting the transient protection. The board operates at a lower cell count without the transient protection adjustment, but users must be sure they provide adequate protection for the IC in the evaluation and system design to prevent damage. The table describes a change from the 8-cell default to one of the other configurations. The users must check configurations if multiple changes are made. D14 is shown removed in the table for less than 8 cells to avoid any possible leakage current or unexpected clamp during evaluation.

**Table 9. Cell Count Component Configuration**

Cell Count/ Reference Designator	8 Cells (Default)	7 Cells	6 Cells	5 Cells	4 Cells
C6	Installed	Remove	Installed	Installed	Installed
C7	Installed	Installed	Remove	Installed	Installed
C8	Installed	Installed	Installed	Remove	Installed
C9	Installed	Installed	Installed	Installed	Remove
D1	Installed	< 35 V	< 30 V	< 25 V	< 20 V
D9	Installed	< 35 V	< 30 V	< 25 V	< 20 V
D14	Installed	Remove	Remove	Remove	Remove
D15	-	< 35 V	-	-	-
D16	-	-	< 30 V	-	-
D17	-	-	-	< 25 V	-
D18	Installed	Installed	Installed	Installed	Installed
R18	Installed	Remove	Remove	Remove	Remove
R19	Installed	Installed	Remove	Remove	Remove

**Table 9. Cell Count Component Configuration (continued)**

Cell Count/ Reference Designator	8 Cells (Default)	7 Cells	6 Cells	5 Cells	4 Cells
R20	Installed	Installed	Installed	Remove	Remove
R21	Installed	Installed	Installed	Installed	Remove
R53	-	-	-	-	0 Ω
R54	-	-	-	0 Ω	-
R55	-	-	0 Ω	-	-
R56	-	0 Ω	-	-	-
R57	Installed	Remove	Remove	Remove	Remove
R62	-	100 Ω	0 Ω	0 Ω	0 Ω
R63	-	-	100 Ω	0 Ω	0 Ω
R64	-	-	-	100 Ω	0 Ω
R65	-	-	-	-	100 Ω

The cell count programmed in the EEPROM must match the physical connection for proper operation. If the device is programmed for more than the connected cells, the unused cells are still checked by the device and show undervoltage or open-cell faults. If the device is programmed for fewer than the connected cells, the upper cells are ignored and faults on these cells are not checked. Also be aware that the voltage applied to the part can exceed the absolute maximum or show undervoltage when used with the resistor simulator.

### **WARNING**

**When the device is configured for fewer than the connected cells, the device does not monitor the upper cells and does not protect against faults on those unmonitored cells.**

## 7.4 Ground Connection

The IC VSS (ground) reference on the bq77908EVM-001 circuit module is connected to the BATT– at the sense resistor. Note the range of the inputs when considering moving the ground location in an application design. The ground connection must be made at one location on the high-current path to avoid differential voltages on the board ground due to high currents.

## 7.5 Current Sense Connections

R50 and R52 in parallel make the current sense resistor. Two resistors allow for lower heat dissipation per component at a given current and allow flexibility in evaluation. R43 and R44 isolate the sense input pins from the current path transients; C20 and C25 provide filtering. Be aware that C20 and C25 add a time delay to the system current response depending on where sense resistor voltage falls in relation to the threshold voltage. A mismatch in C20 and C25 can convert a common-mode signal to a differential signal at the device pins; the C22 pattern is available if a differential filter is desired.

## 7.6 Filter Capacitors

The regulator filter capacitor C17 value of 4.7 μF exceeds the minimum data sheet value of 1 μF. The 1-μF DCAP and CCAP filter capacitors C21 and C26 are the data sheet recommended typical values

## 7.7 FET Circuits

The circuit board has five TO-220 power FET patterns to allow flexibility in evaluation. By default, the board is populated for parallel FET operation. The Q3 discharge FET is mounted to a heatsink expecting high-discharge currents. Users must monitor temperature in their evaluation environment and provide additional cooling if required. Q7 is the parallel charge FET. Anticipating a low-charge current of up to a couple amperes, Q7 does not have a heatsink. Users must measure the device temperature in their evaluation environment and provide heatsinking and cooling, if required.

The Q4 pattern allows an FET to be installed instead of Q7 to provide series FET configuration. In this case, the pack negative is the CHG- terminal. HS2 pattern is provided for Q4. If configured for series FETs, it is recommended to insulate DSG- to avoid erroneous connections. Patterns Q5 and Q6 are in parallel with Q3 and Q4 to provide for optional patterns, to allow parallel FET connection, to provide for a large heatsink to be mounted to the FETs off the board edge if desired, or to provide connection points for additional circuitry. When using series FETs the CPCKN can rise above VSS when the FETs are shut off or the device is shut down. This can result in an increased supply current. Look for TI application reports related to the device for alternate series FET configurations on the Texas Instruments Web site..

C34 and C35 provide an ESD path and high-frequency bypass during switching of the discharge FET. Two capacitors in series are used so that if one is shorted, the other still blocks dc signals. C36 and C37 provide a similar function for the charge FET or across both FETs in series configuration.

Several other components relate to the FET operation. R48 and R49 pull down the gate to source voltage for the FETs to keep them off when the bq77908 is shut down. R41 is the discharge FET gate drive resistor, 1 k $\Omega$  on the EVM. This value adjusts the turnoff time of the discharge FET. Increasing the turnoff time reduces the inductive transients during a protection event, but increases heating in the discharge FET. FET turn on is also affected, so be sure to consider this if the system can turn on with load applied. The 1-k $\Omega$  value may need to be adjusted for your application or other FETs; consult the FET vendor data. R51 and C33 patterns provide locations to provide feedback to slow the discharge FET switching if appropriate in your application. The charge FET typically can be allowed to switch faster due to lower current. The value of R47 can be adjusted if desired.

When no FETs are desired, Q7 and Q3 can be shorted source to drain. Shorting the FETs is important in this case; both provide a high-current output path and a proper reference for the DPCKN, CPCKN, and CCAP signals. Adjustments to the flag circuitry may also be desired in this configuration.

## 7.8 Detection Sensing

The device detects load presence with the DPCKN pin. This is connected to the discharge negative signal DSG- with R45. The 100- $\Omega$  value is the data sheet recommended typical  $R_{DPCKN}$  and provides some isolation of the pin from load transients. C29 provides some filtering to avoid transients pushing DPCKN above its absolute maximum. D7 is an optional diode to limit the DPCKN voltage to the BAT pin clamp, if required; in testing, it has not appeared necessary. R46 is the  $R_{LDRM\_DET}$  resistor in the data sheet. This resistor discharges the load capacitance and in series FET configuration, pulls down CPCKN to allow turnon of the CHG output. Note that this resistor provides an unswitched load and must not be made too small. R46 might be removed in parallel FET configurations to reduce the battery drain during continued loads after protection because the device has a weak internal pulldown on DPCKN.

CPCKN is the charge negative sense which is used by the device to sense the charge FET source voltage. It is also the negative power supply for the CHG output driver. R40 is the data sheet  $R_{CPCKN}$  and is the typical recommended value. C30 is an optional pattern for filtering, if desired. D8 limits the voltage across BAT to CPCKN during transients or situations when the applied charger voltage exceeds the device absolute maximum. D8 also functions in the series FET configuration to prevent CPCKN from significantly exceeding BAT.

## 7.9 Output Protection Components

D10 is an inductive clamp diode also known as a flyback or freewheel diode. It conducts if the discharge FET opens with an inductive load to clamp the DSG- to the BATT+. Note that inductance of the cells and interconnect is clamped by D9, but load current is handled by D10. D11 prevents CHG- from significantly exceeding BATT+. It provides an inductive load clamp in the series FET configuration when D10 is likely removed. Also in the series FET configuration D11 shorts a reversed charger after the FETs open.



The EVM contains some features to avoid ESD on several of the signals that come to the output side of the board. Spark gaps are provided at most outputs. Pairs of series capacitors bypass most signals to CHG-. If one capacitor is shorted, the other may remain functional. ESD performance of the EVM was not tested, the user must test their system to applicable standards.

### 7.10 Reserved Pins

Pins 23, 24, and 25 of the bq77908 must be tied to GND for normal operation of the device. In an application, these might normally be tied directly to VSS; on the EVM, they are individually pulled down for possible future use. Pin 30 must not be connected in normal operation. The EVM provided the R30 pattern for possible future use. This is omitted for normal designs. Pins 2, 4, and 37 are not connected.

### 7.11 Flag Outputs

CHGFLAG and DSGFLAG are signals output from the board for indicating the CHG and DSG pin status. These are isolated from the device pins by R39 and R34 which prevent excessive loading from shorting the device pins and forcing the FETs off. D6 and D5 prevent current from the board connector pins from driving the device or turning on the FETs due to external connections. If used for monitoring the status, these must have some large-value pulldown. Note that the reference level of the CHGFLAG varies with CHG- when the charge FET is off. If the board is configured to not use a FET and the flag terminals are used as outputs, the appropriate diode can be shorted and resistors adjusted as needed.

### 7.12 Thermal Sensor

The thermal protection on the bq77908EVM circuit module is set to provide a trip threshold between 65°C and 70°C with nominal values. Component tolerances and substitute values may alter this trip point. An onboard thermistor RT1 is mounted near the center top of the board. If RT1 is removed, an offboard thermistor can be connected at J7 or J8 and used for sensing temperature closer to the cells. To adjust the value of the trip point, change the value of R27: Trip ratio is nominally  $0.2 = R_{T(\text{trip})} / (R_{T(\text{trip})} + R27)$ ; consider component and device tolerances as needed for your design. C15 provides some filtering for TS on switching of VTSB; its value can vary but it must not be so large that it prevents the TS signal from stabilizing before temperature measurement. A charger can access the thermistor through J7 and R28. R28 provides for some isolation of the external connection, but is small to reduce error. Adjust R28 as needed for evaluation or system design.

### 7.13 ZEDE

ZEDE is the zero delay test mode control pin of the bq77908. This pin also provides the communication enable to the device for programming and checking the device status. R37 provides a pulldown for ZEDE for normal operation. R9 connects the pin to J3 to allow control by a communication interface. The TI USB-TO-GPIO Interface Adapter has a weak pullup for the signal used to control ZEDE, so the 100-k $\Omega$  value of R37 is larger than the strong pulldown recommended by the data sheet. Connecting J6 pins 2 to 3 provides a lower value pulldown of ZEDE through R23 if needed for evaluation, but prevents data access by the TI Interface Adapter. Connecting J6 pins 1 to 2 pulls up ZEDE to test zero delay mode and allows communication with hosts which do not control ZEDE.

### 7.14 Programming Interface

The serial communication interface is connected to J3 with isolation resistors R12 to R15. D3 provides ESD protection. R16 and R17 pull the lines low when not connected. Pullup resistors for communication with the EVM must be provided by the host or other offboard connection.

Q1, Q2, and related components provide a switch for the 14-V programming voltage controlled by the interface adapter. It is expected that this circuitry is on a production fixture in a system design. R24 provides a pulldown for the EEPROM pin when programming voltage is not present. This resistor can be smaller to avoid noise, depending on the capability of the programming power supply and switch. When programming the EVM with software other than the bq77908GUI Evaluation Software and supported host interface, provide a logic control to the J3 PGM pin at the appropriate time indicated in the data sheet programming diagram.

## 8 bq77908 Circuit Module Physical Construction

This section contains the PCB layout, bill of materials, and schematic of the bq77908EVM circuit module.

The bq77908EVM-001 consists of two circuit module assemblies, the bq77908EVM main board or HPA731, and the resistor simulator or HPA582

### 8.1 Main Board

#### 8.1.1 Board Layout

The bq77908EVM circuit module is a 4.7-inch x 3.25-inch, 4-layer, printed-circuit board assembly. It is designed for easy connection with cell connections on the left side and load connection on the right using standard wires to the terminal blocks. The board was planned for a 30-A current flow. Wide trace areas are used to reduce voltage drops. The EVM layout and construction allows easy understanding of the connections for evaluation, but the connector area and programming features result in a large board. The main solution components are outlined on the silkscreen layer; the discharge FET can be envisioned moving into this area; and the area might further be reduced by careful layout.

See additional information in the configuration and operation sections of this document. [Figure 10](#) to [Figure 17](#) show the board layout.

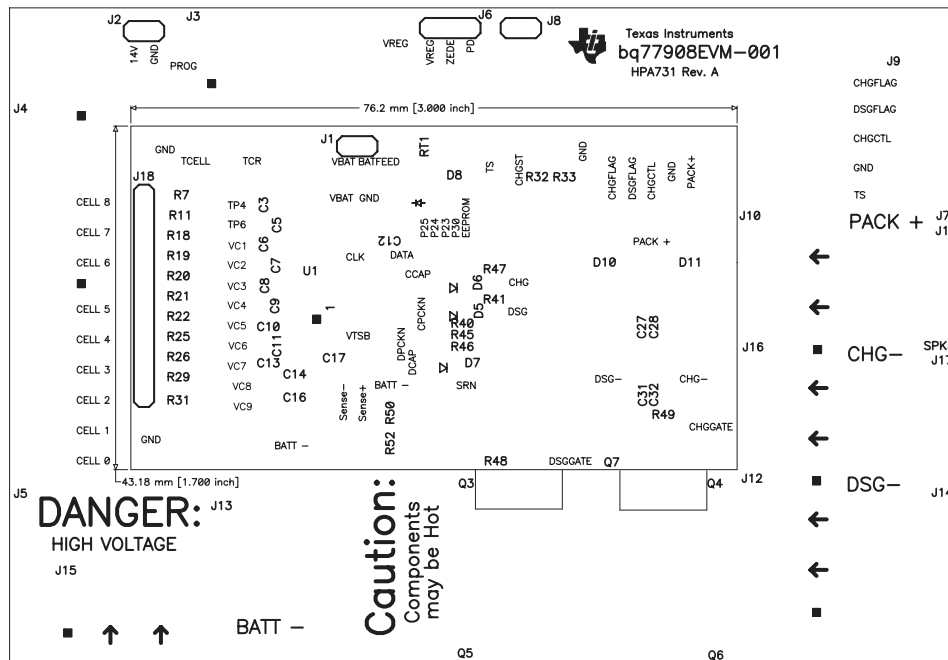
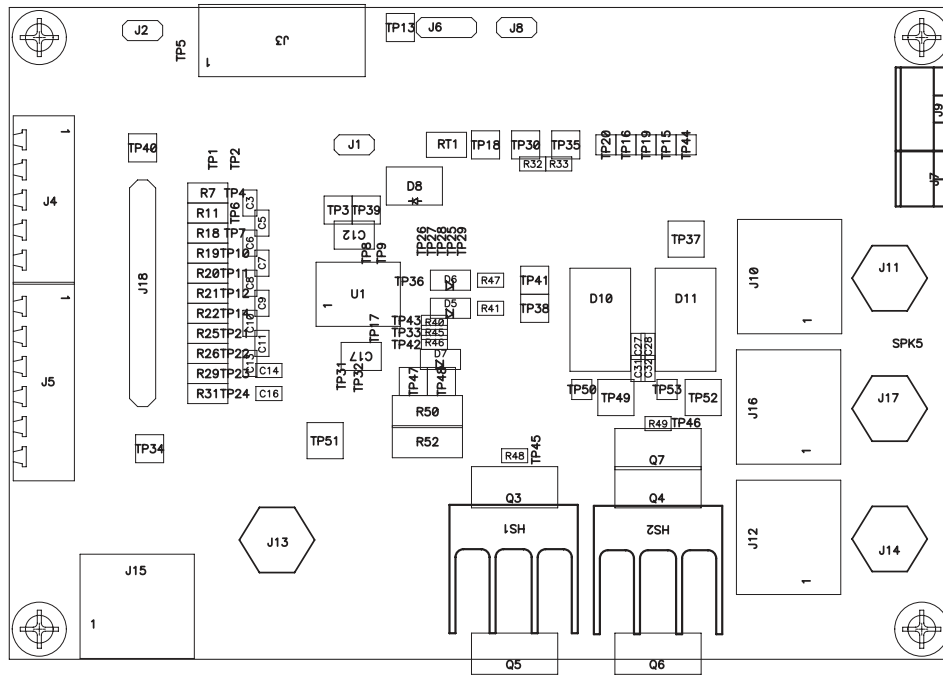
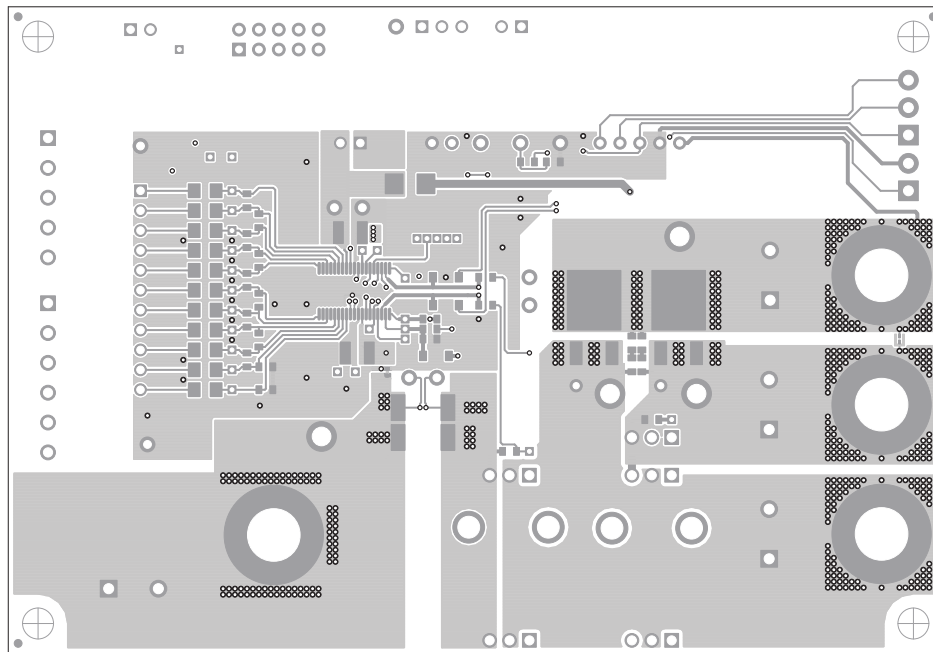

Figure 10. Top Silks Screen



**Figure 11. Top Assembly**



**Figure 12. Top Layer**



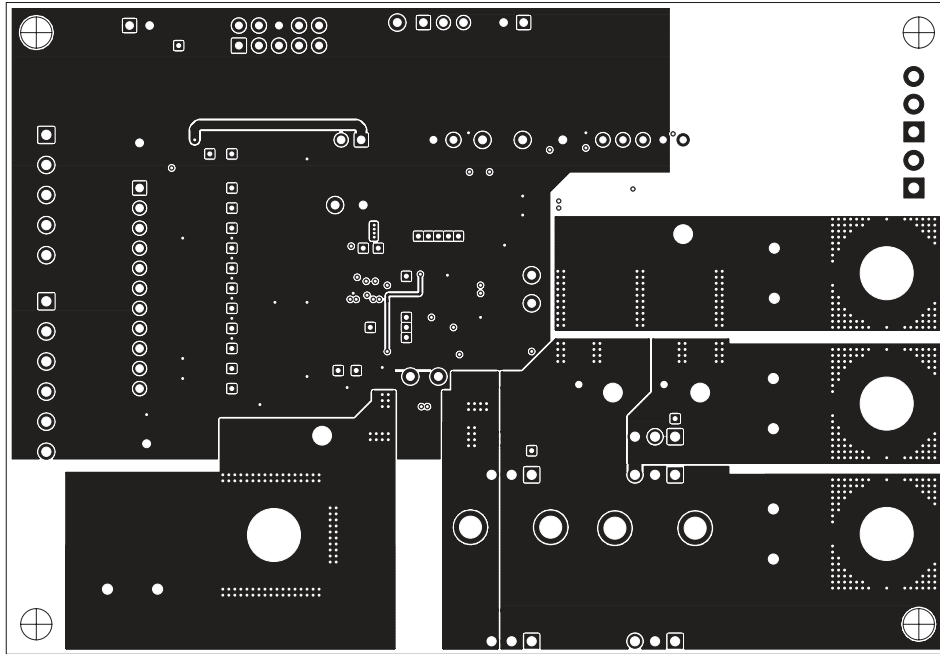

Figure 13. Layer 2

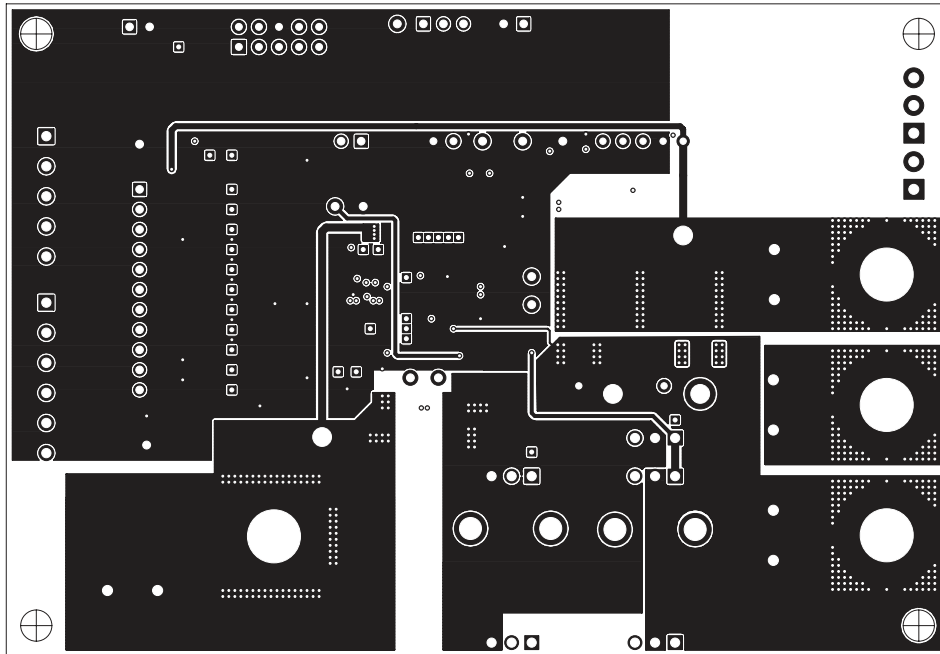

Figure 14. Layer 3



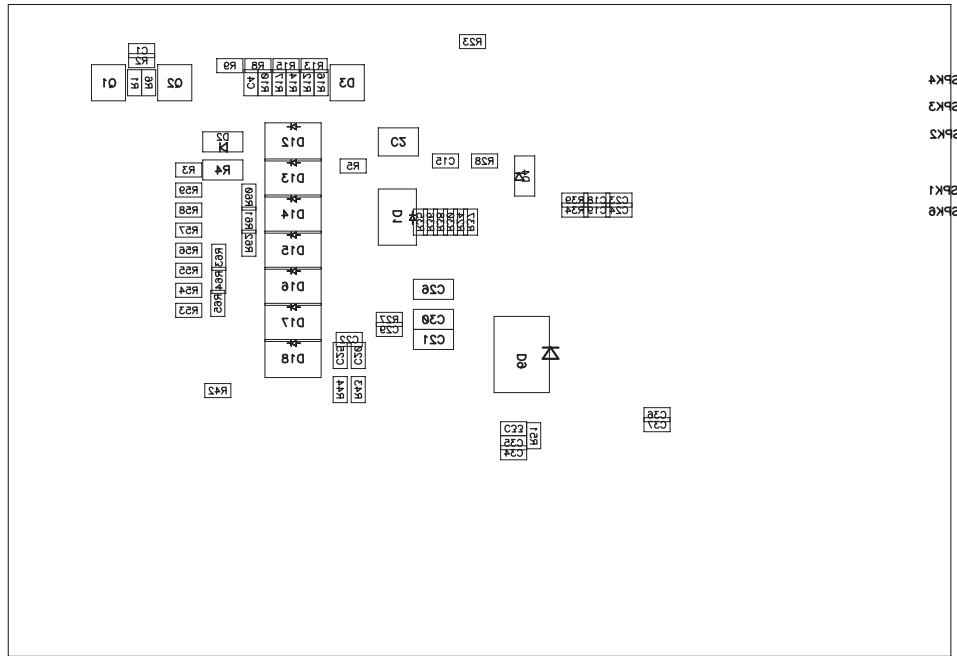

Figure 17. Bottom Assembly

8.1.2 Bill of Materials

The bill of materials for the circuit module is shown in Table 10. Substitute parts may be used in the manufacturing of the assembly.

Table 10. bq77908 Circuit Module Bill of Materials

Count	RefDes	Value	Description	Size	Part Number	MFR
17	C1, C4, C18, C19, C20, C23, C24, C25, C27, C28, C29, C31, C32, C34, C35, C36, C37	0.1 µF	Capacitor, Ceramic, 50V, X7R, 10%	0603	Std	Std
1	C12	0.1 µF	Capacitor, Ceramic, 50V, X7R, 10%	1210	Std	Std
1	C15	10 nF	Capacitor, Ceramic, 50V, X7R, 10%	0603	Std	Std
1	C17	4.7 µF	Capacitor, Ceramic, 50V, X7R, 10%	1210	Std	Std
1	C2	10 µF	Capacitor, Ceramic, 50V, Y5V, 20%	1210	Std	Std
2	C21, C26	1 µF	Capacitor, Ceramic, 25V, X5R, 10%	1206	Std	Std
0	C22		Capacitor, 0603, Not installed	0603		
0	C3, C5		Capacitor, Ceramic, 10V, X7R, 10%	0603		
0	C30		Capacitor, 1206, Not installed	1206		
0	C33		Capacitor, Ceramic, 50V, X7R, 10%	0603		
9	C6, C7, C8, C9, C10, C11, C13, C14, C16	1 µF	Capacitor, Ceramic, 10V, X7R, 10%	0603	Std	Std
2	D1, D14 **	36V TVS	Diode, TVS, Unidirectional, 600-W	SMB	P6SMB36AT3G	ON Semiconductor
2	D10, D11	MURD620CT	Diode, Fast rectifier, 200V, 5A	D-PAK	MURD620CTG or UF5A400D1-13 or RF505B6STL	ON Semiconductor or Diodes or Rohm
0	D12, D13, D15, D16, D17		Diode, TVS, Pattern only, 600-W	SMB		
1	D18 **	17V TVS	Diode, TVS, Unidirectional, 600-W	SMB	1SMB17AT3G	ON Semiconductor
4	D2, D4, D5, D6	1N4148W	Diode, Signal, 300-mA, 75-V, 350-mW	SOD-123	1N4148W-7-F	Diodes
1	D3	5.6V	Diode, Dual, Zener, 5.6V, 300mW	SOT23	AZ23C5V6-V-G	Vishay-Telefunken
0	D7		Diode, Signal, 300-mA, 75-V, 350-mW	SOD-123		
1	D9 **	36V TVS	Diode, Unidirectional TVS, 1500W	SMC	1.5SMC36A	Littelfuse
1	HS1	634-15	Heatsink, TO-220/218 vertical	0.640 x 0.640 inch	634-15ABP	Wakefield
0	HS2		Heatsink, Pattern only, TO-220/218 vertical	0.640 x 0.640 inch		

**Table 10. bq77908 Circuit Module Bill of Materials (continued)**

Count	RefDes	Value	Description	Size	Part Number	MFR
2	J1, J2	PEC02SAAN	Header, Male 2-pin, 100mil spacing	0.100 inch x 2	PEC02SAAN	Sullins
0	J8		Header, Male 2-pin, 100mil spacing			
4	J10, J12, J15, J16	1714955	Header, 32A, 500V, 2-pin, 250 mil spacing	0.492 x 0.500 inch	1714955	Phoenix Contact
4	J11, J13, J14, J17	3267	Connector, Banana Jack, Uninsulated	0.500 dia. inch	3267	Pomona
0	J18		Header, 11-pin, 100mil spacing,	0.100 inch x 11		
1	J3	5103308-1	Header, 2x5-pin, 100mil spacing	0.330 x 0.800 inch	5103308-1	Tyco
1	J4 **	1803455	Header, 8A 300V, 5-pin Vert. Entry	0.280 x 0.700 inch	1803455	Phoenix Contact
1	J5 **	1803468	Header, 8A 300V, 6-pin Vert. Entry	0.2800 x 0.750 inch	1803468	Phoenix Contact
1	J6	PEC03SAAN	Header, Male 3-pin, 100mil spacing,	0.100 inch x 3	PEC03SAAN	Sullins
1	J7	ED555/2DS	Terminal Block, 2-pin, 6-A, 3.5mm	0.27 x 0.25 inch	ED555/2DS	OST
1	J9	ED555/3DS	Terminal Block, 3-pin, 6-A, 3.5mm	0.41 x 0.25 inch	ED555/3DS	OST
1	Q1	BSS84	MOSFET, Pch, -50V, -0.13A, 10 Ω	SOT23	BSS84	Fairchild
1	Q2	BSS138	MOSFET, Nch, 50V, 0.22A, 3.5 Ω	SOT23	BSS138	Fairchild
1	Q3	IRFB3207ZPBF	MOSFET, Nchan, 75V, 170A, 4.1 mΩ	TO-220AB	IRFB3207ZPBF	IR
0	Q4, Q5, Q6		MOSFET, Nchan, Pattern only	TO-220AB		
1	Q7	IRFB3607PBF	MOSFET, Nchan, 75V, 80A, 9 mΩ	TO-220AB	IRFB3607PBF	IR
3	R1, R16, R17	1M	Resistor, Chip, 1/16W, 5%	0603	Std	Std
2	R10, R37	100k	Resistor, Chip, 1/16W, 5%	0603	Std	Std
9	R18, R19, R20, R21, R22, R25, R26, R29, R31	47	Resistor, Metal Film, 1/4 watt, ± 5%	1206	Std	Std
3	R2, R6, R46	47k	Resistor, Chip, 1/16W, 5%	0603	Std	Std
8	R23, R33, R35, R36, R38, R41, R43, R44	1k	Resistor, Chip, 1/16W, 5%	0603	Std	Std
4	R24, R27, R34, R39	10k	Resistor, Chip, 1/16W, 5%	0603	Std	Std
2	R28, R47	47	Resistor, Chip, 1/16W, 5%	0603	Std	Std
3	R3, R42, R57	0	Resistor, Chip, 1/16W, 5%	0603	Std	Std
0	R30, R51, R53, R54, R55, R56, R58, R59, R60, R61, R62, R63, R65		Resistor, Chip, 1/16W, 5%	0603		
1	R4	200	Resistor, Metal Film, 1/4 watt, ± 5%	1206	Std	Std
2	R48, R49	5.1M	Resistor, Chip, 1/16W, 5%	0603	Std	Std
10	R5, R8, R9, R12, R13, R14, R15, R32, R40, R45	100	Resistor, Chip, 1/16W, 1%	0603	Std	Std
2	R50, R52	0.002	Resistor, 2 mΩ, 1W, 1%	2512	WSL25122L000FEA	Vishay
0	R64		Resistor, Chip, 1/16W, 1%	0603		
0	R7, R11		Resistor, Metal Film, 1/4 watt, ± 5%	1206	Std	Std
1	RT1	10k	Thermistor, TH, ±1%	0.095 X 0.150 inch	103AT-2	Semitec
0	SPK1, SPK2, SPK3, SPK4, SPK5, SPK6		Spark Gap, 0.010 inch space	0.050 x 0.070 inch		
0	TP37, TP49, TP51, TP52		Plated Through Hole, Dia. 0.094	0.150 x 0.150 inch		
4	TP34, TP35, TP39, TP40	5020	Test Point, loop	0.100 x 0.100 inch	5020	Keystone
8	TP13, TP18, TP3, TP30, TP38, TP41, TP47, TP48	5002	Test Point, White, Thru Hole Color Keyed	0.100 x 0.100 inch	5002	Keystone
0	TP1, TP10, TP11, TP12, TP14, TP17, TP2, TP21, TP22, TP23, TP24, TP25, TP26, TP27, TP28, TP29, TP31, TP32, TP33, TP36, TP4, TP42, TP43, TP45, TP46, TP5, TP6, TP7, TP8, TP9		Test Point, 0.020 Hole			
0	TP15, TP16, TP19, TP20, TP44, TP50, TP53		Test Point, 0.032 Hole			
1	U1	bq77908DBT	IC, Multicell Lithium-Ion/Lithium Polymer Pack Protection	TSSOP-38 (DBT)	bq77908DBT	TI
1	--		PCB, 4.7 In x 3.25 In x 0.062 In		HPA731	Any
1	--		Shunt, 100-mil, Black	0.100	929950-00	3M
1	--		Thermal pad		SP900S-0.009-00-54	Bergquist
1	--		Screw, 6-32 x 0.375", pan head, Nylon		Std	Std
1	P4 (##) **		TERMBLOCK PLUG SPOS 3.81MM		1827156	Phoenix Contact
1	P5 (##) **		TERMBLOCK PLUG 6POS 3.81MM		1827169	Phoenix Contact
4	--		Standoff, M-F threaded 6-32, 0.5", Nylon		4816	Keystone

**Table 10. bq77908 Circuit Module Bill of Materials (continued)**

Count	RefDes	Value	Description	Size	Part Number	MFR
4	--		Nut, Hex, 6-32, Nylon		Std	Std
1	--		Resistive Cell Simulator		HPA582	TI

- Notes:
1. These assemblies are ESD sensitive; ESD precautions shall be observed.
  2. These assemblies must be clean and free from flux and all contaminants. Using unclean flux is unacceptable.
  3. These assemblies must comply with workmanship standards IPC-A-610 Class 2.
  4. Reference designators marked with an asterisk (\*\*\*) cannot be substituted. All other components can be substituted with equivalent MFG's components.
  5. Install thermal pad between heatsink & Q3 and secure with screw. If heatsink is substituted, use appropriate screw thread
  6. Provide connectors (##) with assembly, install on J4 and J5 after test
  7. Install shunt on J1 during test
  8. Install standoffs at board corners, nut on top

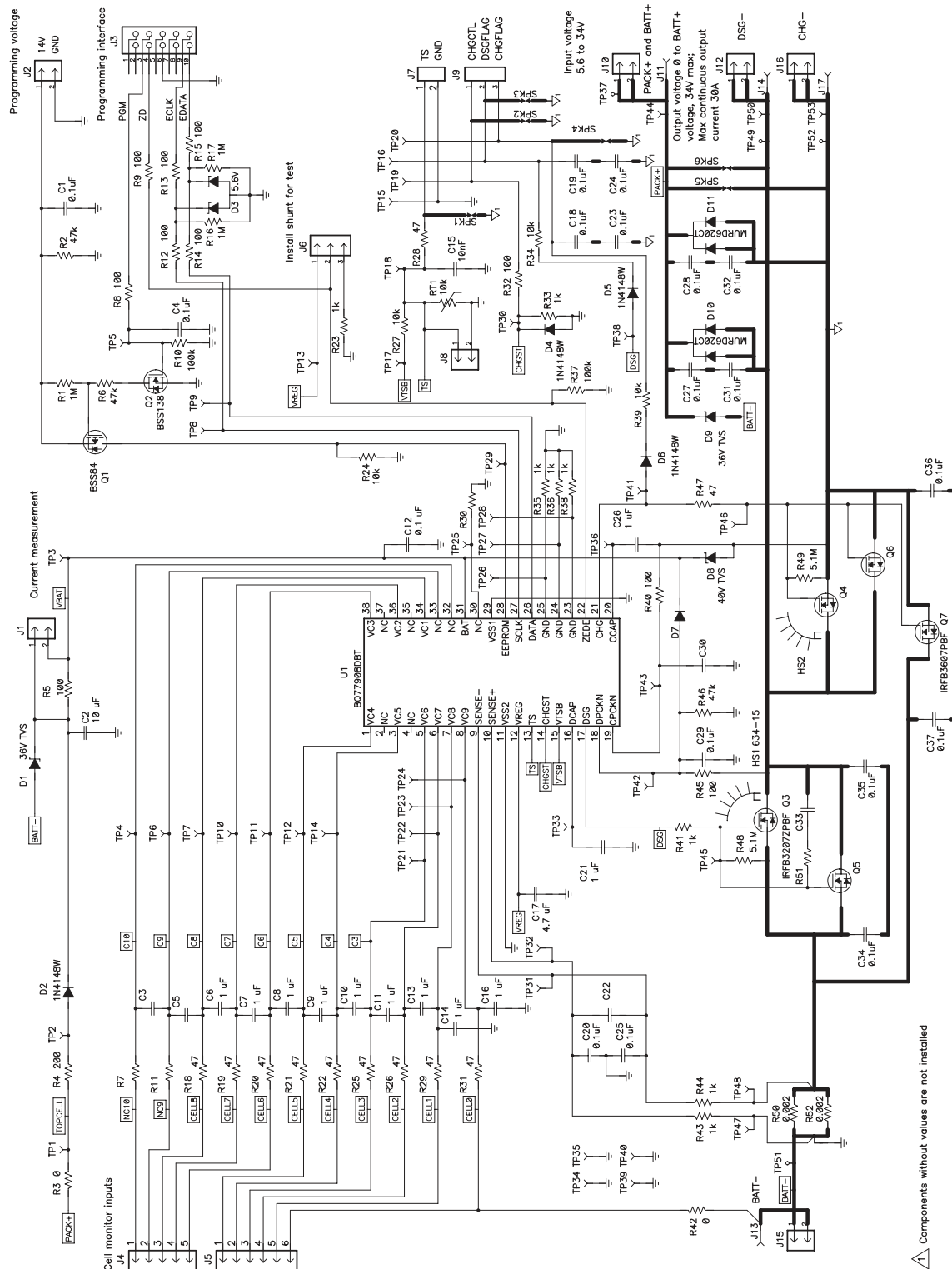

Figure 18. Schematic Diagram, Sheet 1 of 2

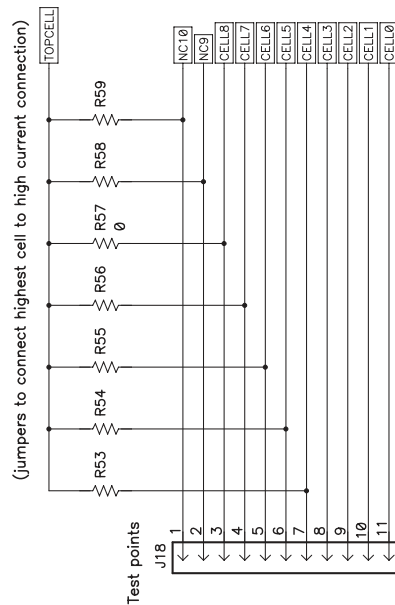
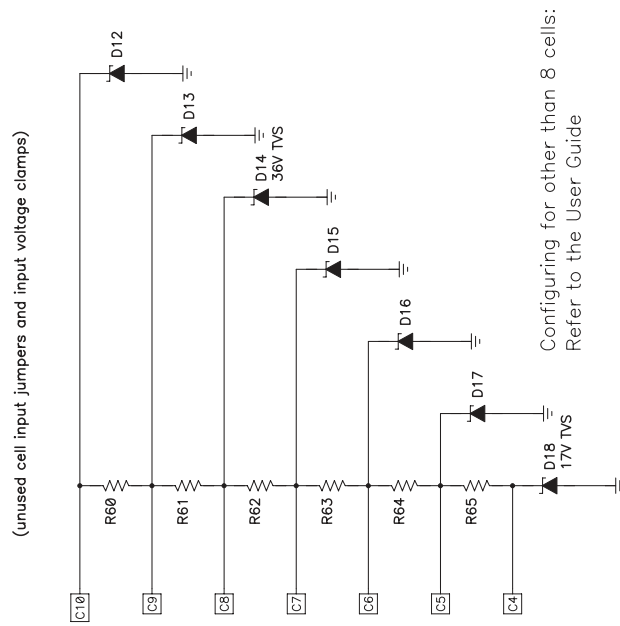

Figure 19. Schematic Diagram, Sheet 2 of 2

### 8.1.3 bq77908 Circuit Module Performance Specification Summary

This section summarizes the performance specifications of the bq77908 circuit module in its default 8-cell parallel FET configuration.

Typical voltage depends on the number of cells configured. Typical current depends on the application. Board cooling may be required for continuous operation at or below maximum current.

**Table 11. Performance Specification Summary**

Specification	Min	Typ	Max	Unit
Input voltage PACK+ with respect to BATT-, CHG-, or DSG-	5.6	-	34	V
Continuous discharge current (current into DSG- terminal)	0	-	30	A
Continuous charge current (current into CHG- terminal)	0	-	-6	A

## 8.2 Resistor Cell Simulator

### 8.2.1 Board Layout

The resistor cell simulator is a 1.75-inch x 2.00-inch, 2-layer circuit board assembly. It is designed for easy connection to the bq77908 circuit board assembly using the connectors on the bottom side. Additional patterns are included on the board for test points.

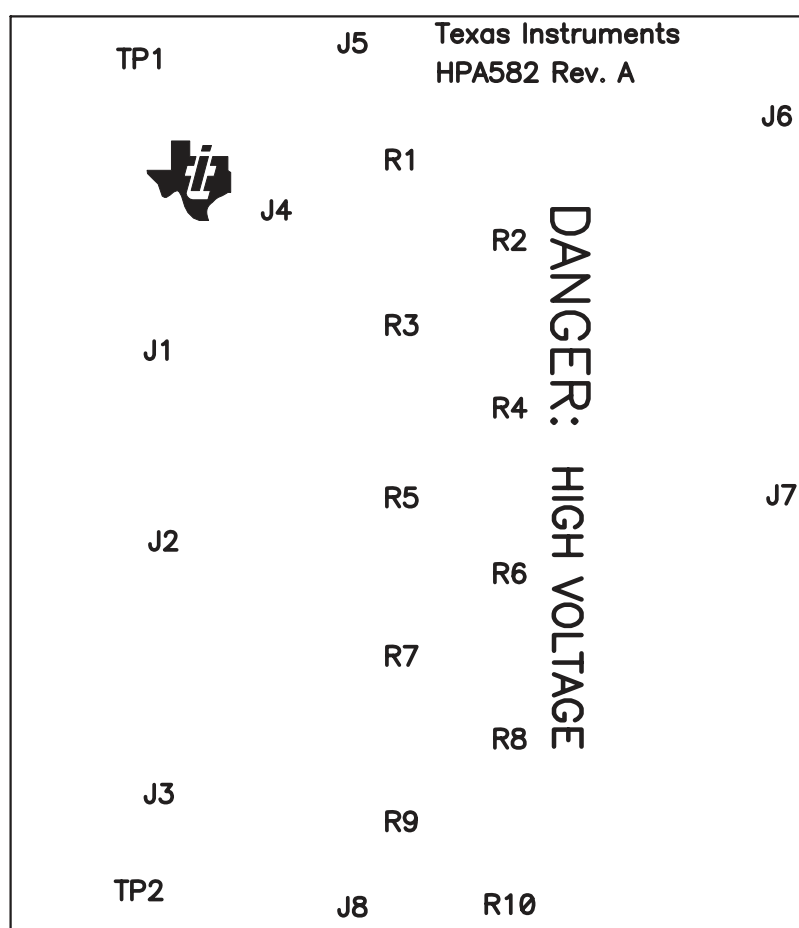
**Figure 20. Resistor Simulator Top Silk Screen**



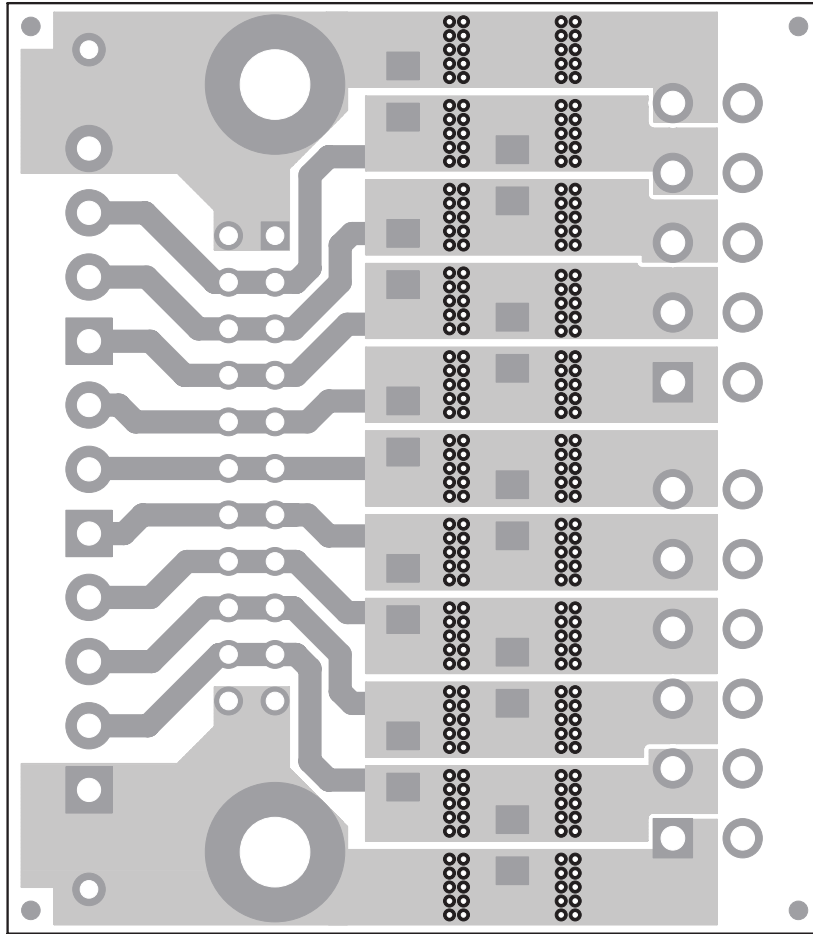

**Figure 21. Resistor Simulator Top Layer**

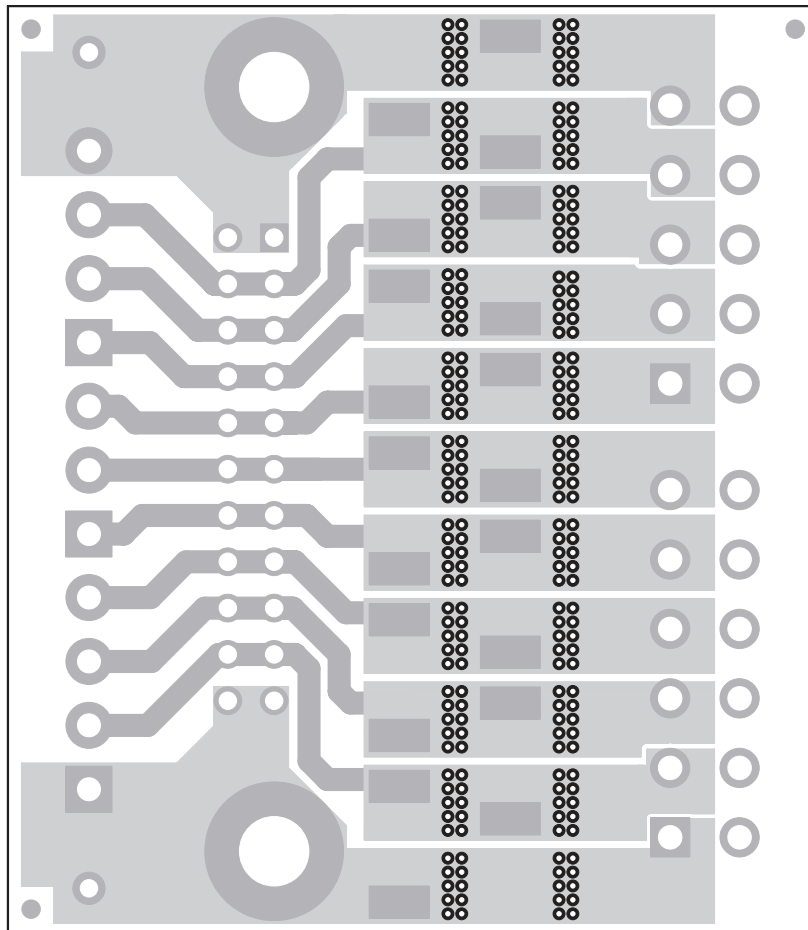

**Figure 22. Resistor Simulator Bottom Layer**

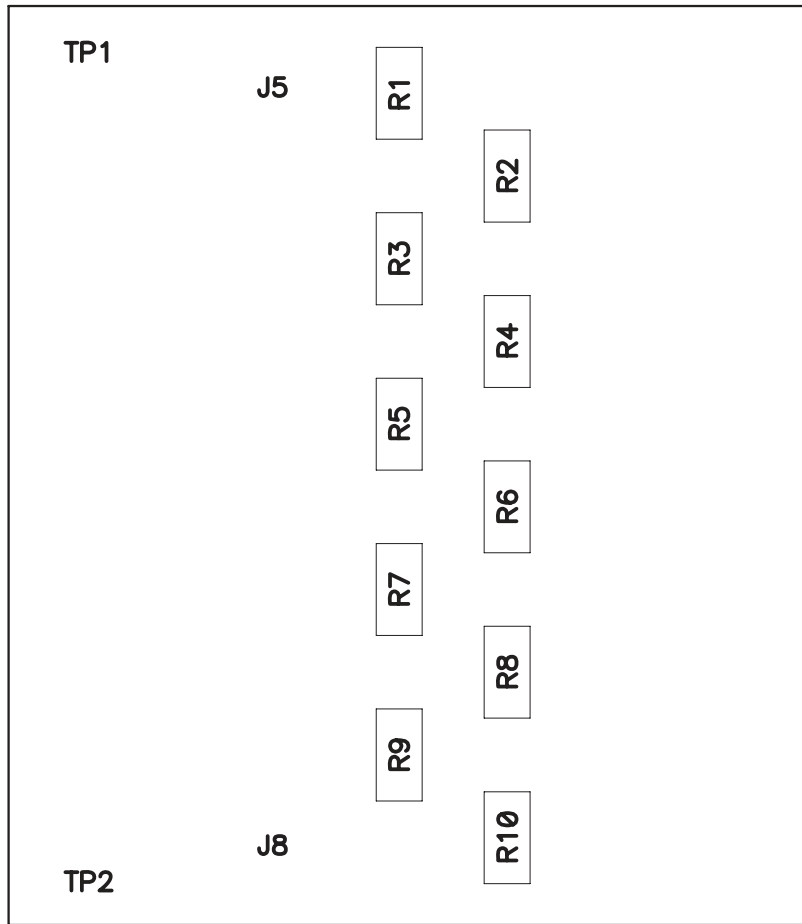
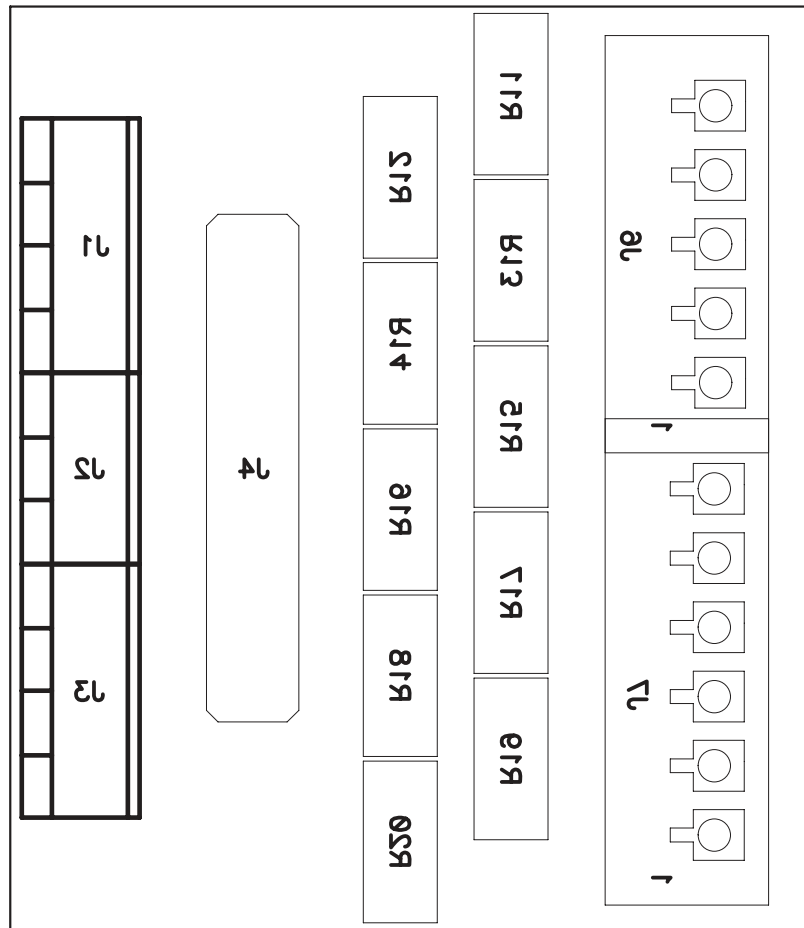

Figure 23. Resistor Simulator Top Assembly

**Figure 24. Resistor Simulator Bottom assembly**

### 8.2.2 Resistor Simulator Bill of Materials

The bill of materials for the Resistor Simulator circuit module is shown in [Table 12](#).

**Table 12. Resistor Simulator Bill of Materials**

Count	RefDes	Value	Description	Size	Part Number	MFR
0	J1, J3		Terminal Block, 4-pin, 6-A, 3.5mm	0.55 x 0.25 inch	ED555/4DS	OST
0	J2		Terminal Block, 3-pin, 6-A, 3.5mm	0.41 x 0.25 inch	ED555/3DS	OST
0	J4		Header, Male 2x11-pin, 100mil spacing	0.100 inch x 11 x 2	PEC11DAAN	Sullins
0	J5, J8		150-mil hole for standard banana plug	0.300 dia inch		
1	J6 **	1875454	Header, 8A, 160V, 5-pin, 3.81 mm spacing, Top Entry	6.85 x 22.96 mm	1875454	Phoenix Contact
1	J7 **	1875467	Header, 8A, 160V, 6-pin, 3.81 mm spacing, Top Entry	6.85 x 26.77 mm	1875467	Phoenix Contact
10	R1, R2, R3, R4, R5, R6, R7, R8, R9, R10,	200	Resistor, Metal Film, 1/4 watt, ± 1%	1206	STD	STD
0	R11, R12, R13, R14, R15, R16, R17, R18, R19, R20		Resistor, Chip, 1W, 1%	2512		
0	TP1, TP2		Pad, TH	0.038 inch		
1	--		PCB, 2 ln x 1.75 ln x 0.062 ln		HPA582	Any

Notes: 1. These assemblies are ESD sensitive; ESD precautions shall be observed.

**Table 12. Resistor Simulator Bill of Materials (continued)**

Count	RefDes	Value	Description	Size	Part Number	MFR
	2.		These assemblies must be clean and free from flux and all contaminants. Using unclean flux is unacceptable.			
	3.		These assemblies must comply with workmanship standards IPC-A-610 Class 2.			
	4.		Reference designators marked with an asterisk (***) cannot be substituted. All other components can be substituted with equivalent MFG's components.			



## Evaluation Board/Kit Important Notice

Texas Instruments (TI) provides the enclosed product(s) under the following conditions:

This evaluation board/kit is intended for use for **ENGINEERING DEVELOPMENT, DEMONSTRATION, OR EVALUATION PURPOSES ONLY** and is not considered by TI to be a finished end-product fit for general consumer use. Persons handling the product(s) must have electronics training and observe good engineering practice standards. As such, the goods being provided are not intended to be complete in terms of required design-, marketing-, and/or manufacturing-related protective considerations, including product safety and environmental measures typically found in end products that incorporate such semiconductor components or circuit boards. This evaluation board/kit does not fall within the scope of the European Union directives regarding electromagnetic compatibility, restricted substances (RoHS), recycling (WEEE), FCC, CE or UL, and therefore may not meet the technical requirements of these directives or other related directives.

Should this evaluation board/kit not meet the specifications indicated in the User's Guide, the board/kit may be returned within 30 days from the date of delivery for a full refund. **THE FOREGOING WARRANTY IS THE EXCLUSIVE WARRANTY MADE BY SELLER TO BUYER AND IS IN LIEU OF ALL OTHER WARRANTIES, EXPRESSED, IMPLIED, OR STATUTORY, INCLUDING ANY WARRANTY OF MERCHANTABILITY OR FITNESS FOR ANY PARTICULAR PURPOSE.**

The user assumes all responsibility and liability for proper and safe handling of the goods. Further, the user indemnifies TI from all claims arising from the handling or use of the goods. Due to the open construction of the product, it is the user's responsibility to take any and all appropriate precautions with regard to electrostatic discharge.

**EXCEPT TO THE EXTENT OF THE INDEMNITY SET FORTH ABOVE, NEITHER PARTY SHALL BE LIABLE TO THE OTHER FOR ANY INDIRECT, SPECIAL, INCIDENTAL, OR CONSEQUENTIAL DAMAGES.**

TI currently deals with a variety of customers for products, and therefore our arrangement with the user **is not exclusive.**

TI assumes **no liability for applications assistance, customer product design, software performance, or infringement of patents or services described herein.**

Please read the User's Guide and, specifically, the Warnings and Restrictions notice in the User's Guide prior to handling the product. This notice contains important safety information about temperatures and voltages. For additional information on TI's environmental and/or safety programs, please contact the TI application engineer or visit [www.ti.com/esh](http://www.ti.com/esh).

No license is granted under any patent right or other intellectual property right of TI covering or relating to any machine, process, or combination in which such TI products or services might be or are used.

## FCC Warning

This evaluation board/kit is intended for use for **ENGINEERING DEVELOPMENT, DEMONSTRATION, OR EVALUATION PURPOSES ONLY** and is not considered by TI to be a finished end-product fit for general consumer use. It generates, uses, and can radiate radio frequency energy and has not been tested for compliance with the limits of computing devices pursuant to part 15 of FCC rules, which are designed to provide reasonable protection against radio frequency interference. Operation of this equipment in other environments may cause interference with radio communications, in which case the user at his own expense will be required to take whatever measures may be required to correct this interference.

## EVM Warnings and Restrictions

It is important to operate this EVM within the input voltage range of 0 V to 34 V and the output voltage range of 0 V to 34 V .

Exceeding the specified input range may cause unexpected operation and/or irreversible damage to the EVM. If there are questions concerning the input range, please contact a TI field representative prior to connecting the input power.

Applying loads outside of the specified output range may result in unintended operation and/or possible permanent damage to the EVM. Please consult the EVM User's Guide prior to connecting any load to the EVM output. If there is uncertainty as to the load specification, please contact a TI field representative.

During normal operation, some circuit components may have case temperatures greater than 60°C. The EVM is designed to operate properly with certain components above 60°C as long as the input and output ranges are maintained. These components include but are not limited to linear regulators, switching transistors, pass transistors, and current sense resistors. These types of devices can be identified using the EVM schematic located in the EVM User's Guide. When placing measurement probes near these devices during operation, please be aware that these devices may be very warm to the touch.

Mailing Address: Texas Instruments, Post Office Box 655303, Dallas, Texas 75265  
Copyright © 2011, Texas Instruments Incorporated

## IMPORTANT NOTICE

Texas Instruments Incorporated and its subsidiaries (TI) reserve the right to make corrections, modifications, enhancements, improvements, and other changes to its products and services at any time and to discontinue any product or service without notice. Customers should obtain the latest relevant information before placing orders and should verify that such information is current and complete. All products are sold subject to TI's terms and conditions of sale supplied at the time of order acknowledgment.

TI warrants performance of its hardware products to the specifications applicable at the time of sale in accordance with TI's standard warranty. Testing and other quality control techniques are used to the extent TI deems necessary to support this warranty. Except where mandated by government requirements, testing of all parameters of each product is not necessarily performed.

TI assumes no liability for applications assistance or customer product design. Customers are responsible for their products and applications using TI components. To minimize the risks associated with customer products and applications, customers should provide adequate design and operating safeguards.

TI does not warrant or represent that any license, either express or implied, is granted under any TI patent right, copyright, mask work right, or other TI intellectual property right relating to any combination, machine, or process in which TI products or services are used. Information published by TI regarding third-party products or services does not constitute a license from TI to use such products or services or a warranty or endorsement thereof. Use of such information may require a license from a third party under the patents or other intellectual property of the third party, or a license from TI under the patents or other intellectual property of TI.

Reproduction of TI information in TI data books or data sheets is permissible only if reproduction is without alteration and is accompanied by all associated warranties, conditions, limitations, and notices. Reproduction of this information with alteration is an unfair and deceptive business practice. TI is not responsible or liable for such altered documentation. Information of third parties may be subject to additional restrictions.

Resale of TI products or services with statements different from or beyond the parameters stated by TI for that product or service voids all express and any implied warranties for the associated TI product or service and is an unfair and deceptive business practice. TI is not responsible or liable for any such statements.

TI products are not authorized for use in safety-critical applications (such as life support) where a failure of the TI product would reasonably be expected to cause severe personal injury or death, unless officers of the parties have executed an agreement specifically governing such use. Buyers represent that they have all necessary expertise in the safety and regulatory ramifications of their applications, and acknowledge and agree that they are solely responsible for all legal, regulatory and safety-related requirements concerning their products and any use of TI products in such safety-critical applications, notwithstanding any applications-related information or support that may be provided by TI. Further, Buyers must fully indemnify TI and its representatives against any damages arising out of the use of TI products in such safety-critical applications.

TI products are neither designed nor intended for use in military/aerospace applications or environments unless the TI products are specifically designated by TI as military-grade or "enhanced plastic." Only products designated by TI as military-grade meet military specifications. Buyers acknowledge and agree that any such use of TI products which TI has not designated as military-grade is solely at the Buyer's risk, and that they are solely responsible for compliance with all legal and regulatory requirements in connection with such use.

TI products are neither designed nor intended for use in automotive applications or environments unless the specific TI products are designated by TI as compliant with ISO/TS 16949 requirements. Buyers acknowledge and agree that, if they use any non-designated products in automotive applications, TI will not be responsible for any failure to meet such requirements.

Following are URLs where you can obtain information on other Texas Instruments products and application solutions:

### Products

Audio	<a href="http://www.ti.com/audio">www.ti.com/audio</a>
Amplifiers	<a href="http://amplifier.ti.com">amplifier.ti.com</a>
Data Converters	<a href="http://dataconverter.ti.com">dataconverter.ti.com</a>
DLP® Products	<a href="http://www.dlp.com">www.dlp.com</a>
DSP	<a href="http://dsp.ti.com">dsp.ti.com</a>
Clocks and Timers	<a href="http://www.ti.com/clocks">www.ti.com/clocks</a>
Interface	<a href="http://interface.ti.com">interface.ti.com</a>
Logic	<a href="http://logic.ti.com">logic.ti.com</a>
Power Mgmt	<a href="http://power.ti.com">power.ti.com</a>
Microcontrollers	<a href="http://microcontroller.ti.com">microcontroller.ti.com</a>
RFID	<a href="http://www.ti-rfid.com">www.ti-rfid.com</a>
RF/IF and ZigBee® Solutions	<a href="http://www.ti.com/lprf">www.ti.com/lprf</a>

### Applications

Communications and Telecom	<a href="http://www.ti.com/communications">www.ti.com/communications</a>
Computers and Peripherals	<a href="http://www.ti.com/computers">www.ti.com/computers</a>
Consumer Electronics	<a href="http://www.ti.com/consumer-apps">www.ti.com/consumer-apps</a>
Energy and Lighting	<a href="http://www.ti.com/energy">www.ti.com/energy</a>
Industrial	<a href="http://www.ti.com/industrial">www.ti.com/industrial</a>
Medical	<a href="http://www.ti.com/medical">www.ti.com/medical</a>
Security	<a href="http://www.ti.com/security">www.ti.com/security</a>
Space, Avionics and Defense	<a href="http://www.ti.com/space-avionics-defense">www.ti.com/space-avionics-defense</a>
Transportation and Automotive	<a href="http://www.ti.com/automotive">www.ti.com/automotive</a>
Video and Imaging	<a href="http://www.ti.com/video">www.ti.com/video</a>
Wireless	<a href="http://www.ti.com/wireless-apps">www.ti.com/wireless-apps</a>

TI E2E Community Home Page

[e2e.ti.com](http://e2e.ti.com)

Mailing Address: Texas Instruments, Post Office Box 655303, Dallas, Texas 75265  
Copyright © 2011, Texas Instruments Incorporated