

1	2	3	4	5	6	7
CINCH Connectors Ltd. WORKSOP, ENGLAND						
A		JA		83384 00 A0P		R01
RELEVANT SPEC.		SHEET 1 OF 1		CAD No. P:R7683384 \		
IF IN DOUBT - ASK ALL DIMENSIONS ARE IN mm						

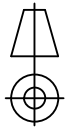
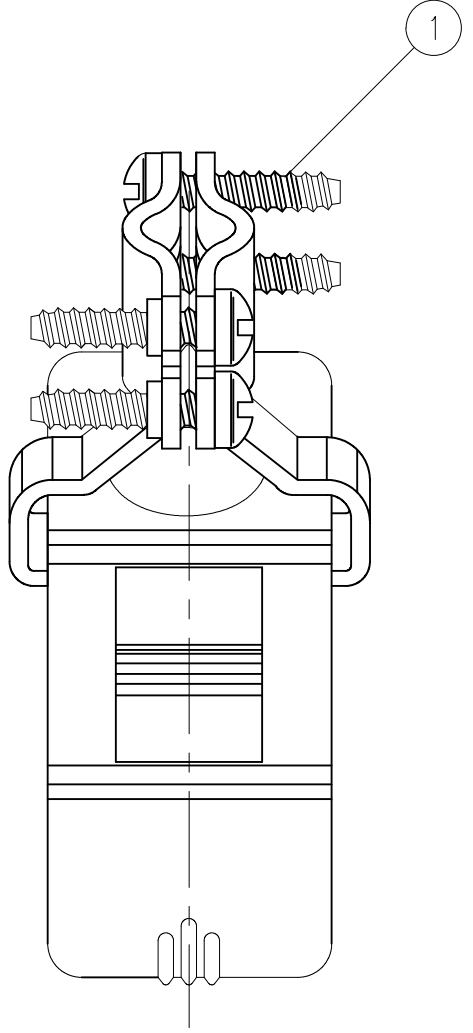
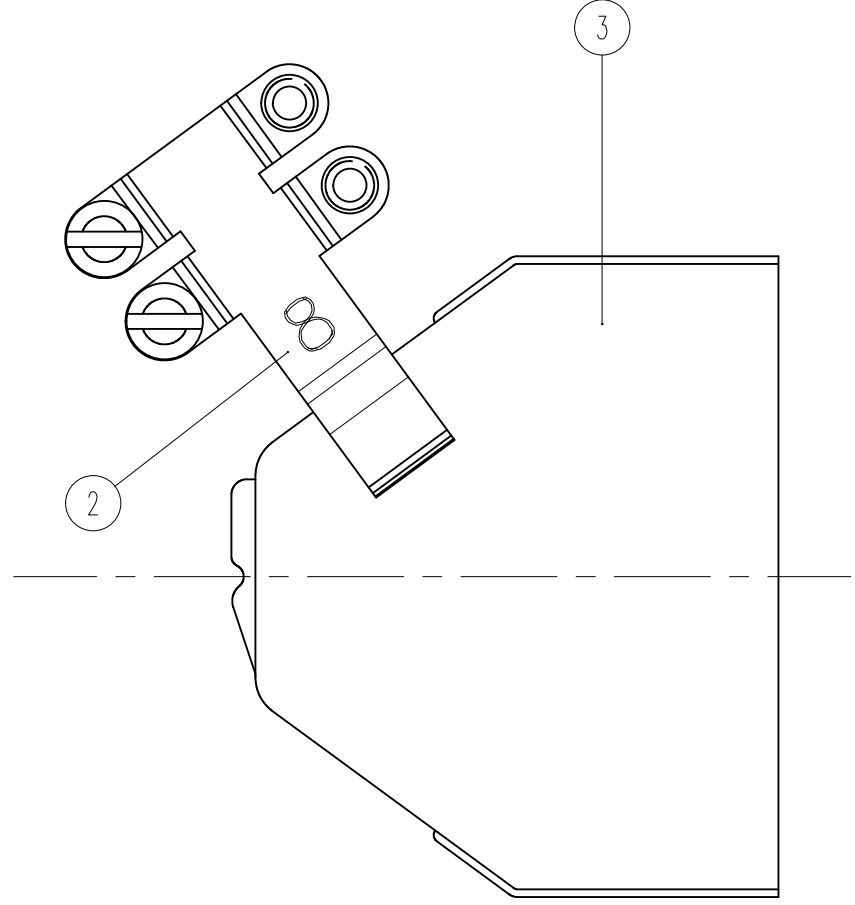

CUSTOMER DRAWING ONLY.

THIS DRAWING IS COPYRIGHT AND IS ISSUED ON CONDITION IT IS NOT COPIED, REPRODUCED OR DISCLOSED TO A THIRD PARTY WITHOUT THE CONSENT IN WRITING OF CINCH CONNECTORS LTD. ATTENTION IS DRAWN TO THE FACT THAT THE ARTICLE DISCLOSED MAY BE COVERED BY BRITISH OR FOREIGN PATENTS, GRANTED OR PENDING OR REGISTERED DESIGN.

APP'D		DATE		CUST ISS.		9.9.80		12.4.95		R15308		A	
DESCRIPTION		FINISH		No. OFF		ISSUE		GENERAL TOLERANCE		TITLE		8 WAY MOULDED SHELL ASSEMBLY	
CODE		FINISH		No. OFF		ISSUE		2 DECIMAL PLACES ± 0.10		DRN. D.J.POLLARD.		DATE 25.07.95	
DESCRIPTION		FINISH		No. OFF		ISSUE		1 DECIMAL PLACE ± 0.20		SCALE 2:1		CHD MB.	
SHELL		FINISH		No. OFF		ISSUE		NO. DECIMAL PLACE ± 0.50		MATERIAL SPEC.		APP'D GSF.	
CLEAT		FINISH		No. OFF		ISSUE		ANGULAR ± 1°		RAW MATERIAL		FINISHED COLOUR	
SCREW		FINISH		No. OFF		ISSUE		0.18 MAX TOOLING RAD.		FINISHED HARDNESS		FINISH TREATMENT	