

Sleeve (Stainless Steel)
Hülse (Edelstahl):

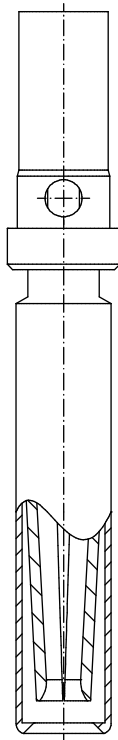

Materials/

Werkstoffe:	
Contact/ Kontakt:	Cu alloy, Au over Ni
Sleeve/ Hülse:	Stainless Steel/ Edelstahl:

Installation specification/

Montagedaten:	
Crimp-Tool/ Crimp-Werkzeug:	360X10329X
Tool Insert/ Werkzeug Einsatz:	360X20039X
Selector Settings/ Selektor Einstellungen:	7 for AWG 24 6 for AWG 26 5 for AWG 28

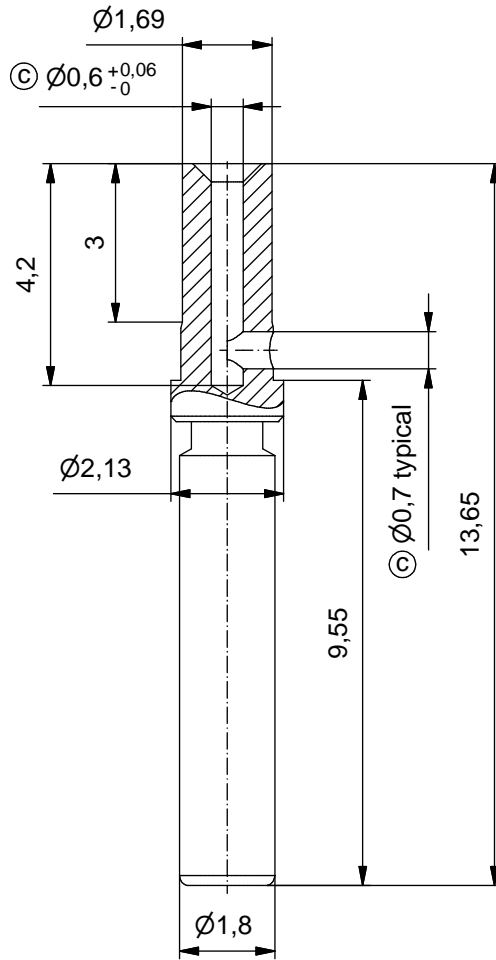

**Stripping Dimensions/
Kabelvorbereitung:**

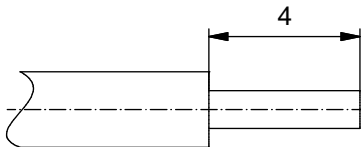

Part no. / Art.-Nr.:	Plating / Veredelung:
132C15029X	min. 30 µin hard Gold over min. 50 µin Nickel min. 30 µin Gold über min. 50 µin Nickel
132J15029X	min. 50 µin hard Gold over min. 50 µin Nickel min. 50 µin Gold über min. 50 µin Nickel

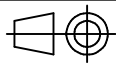

dim. in mm

Signal Crimp-Contact Socket Contact
Wire Size 24-28

Signal Crimp-Kontakt Buchsenkontakt

Kabelgröße 24-28

general tolerance/
Allgemeintoleranz: ISO 2768-m

	Date/Datum	Name
drawn/ gez.	15.07.10	Schmidt
appd./ gepr.	15.07.10	Koch

Index: c Ä6258 15.08.16 JL

scale/Maßstab:



dwg no /
Z.-nr.:

16K1A2679

DIN-
A4

Status: InBearbeitung

7:1

RoHS & REACH compliant/konform

1 / 1

The reproduction, distribution and utilization of this document as well as the communication of its contents to others without express authorization is prohibited. Offenders will be held liable for the payment of damages. An exemption does not apply to the extent that it is necessary for the reproduction of the document for private use only. Die Vervielfältigung, Verbreitung, die öffentliche oder geschäftliche Nutzung dieses Dokuments, die Kommunikation seines Inhalts sind verboten, soweit nicht ausdrücklich gestattet. Zuwiderhandlungen verpflichten zu Schadenersatz. Alle Rechte für den Fall der Patent-, Gebrauchsmarken- oder Geschmacksmarkenregistrierung vorbehalten.