

### FEATURES

- Evaluation kit for the ADM1185 quad voltage monitor and sequencer
- 6 LEDs indicate power supply status, providing a clear visual indication of the power-up sequence
- Dedicated power and enable/disable switches
- On-board test points allow examination of the ADM1185's operation

### EVALUATION KIT CONTENTS

- ADM1185 main evaluation board
- ADM1185 data sheet
- EVAL-ADM1185EBZ evaluation kit data sheet
- 2 ADM1185 samples

### GENERAL DESCRIPTION

The EVAL-ADM1185EBZ evaluation kit demonstrates how the ADM1185 can provide quad voltage monitoring and sequencing in multiple supply systems.

The ADM1185 monitors four separate voltage rails, turns on three regulators in a predefined sequence, and generates a power-good signal when all supplies are operating and stable.

LEDs provide a visual indication of the status of the main supply voltage, each of the four inputs, and the system power-good signal (PWRGD).

Four on-board rotary switches allow the user to investigate the result of altering each of the monitored input voltages. The user can simulate fault conditions during power up and while the ADM1185 is in the power-good state.

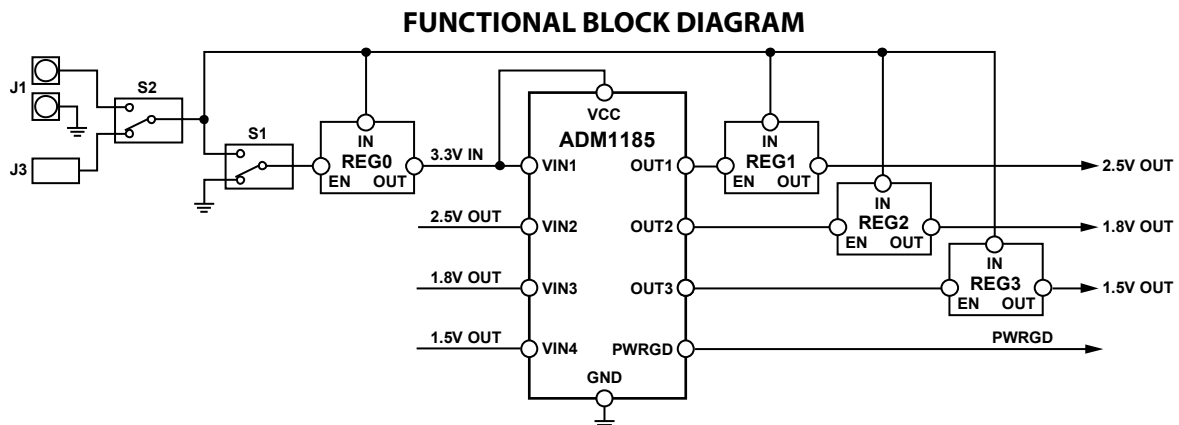

Figure 1.

06728-001

### Rev. PrA

Information furnished by Analog Devices is believed to be accurate and reliable. However, no responsibility is assumed by Analog Devices for its use, nor for any infringements of patents or other rights of third parties that may result from its use. Specifications subject to change without notice. No license is granted by implication or otherwise under any patent or patent rights of Analog Devices. Trademarks and registered trademarks are the property of their respective owners.

**TABLE OF CONTENTS**

Features .....	1	Theory of Operation .....	5
Evaluation Kit Contents.....	1	Simulating a Power-Up Sequence .....	5
General Description .....	1	Observing Fault Conditions During Power On .....	5
Functional Block Diagram .....	1	Observing Fault Conditions Following Power On .....	6
Revision History .....	2	Additional Delays .....	6
Evaluation Board Hardware .....	3	Evaluation Board Schematics.....	7
Connector, Switch, Jumper, LED, and Test Point Functions.....	3	Ordering Information.....	9
Evaluation Board Operation .....	5	Bill of Materials.....	9
ADM1185 Samples.....	5	Ordering Guide .....	10
Powering the Evaluation Board.....	5	ESD Caution.....	10
Setting Voltage-Detection Levels.....	5		

**REVISION HISTORY**

5/07—Revision PrA: Initial Version

## EVALUATION BOARD HARDWARE

### CONNECTOR, SWITCH, JUMPER, LED, AND TEST POINT FUNCTIONS

Table 1. Connector Functions

Pin	Name	Function
J1	Power connector	J1-1: Connects the positive terminal of the bench power supply to the board J1-2: Connects the ground terminal of the bench power supply to the board
J3	Terminal block	J3-1: Connects a 9 V power supply to the evaluation board J3-2: Connects a 9 V power supply to ground
J9	6W_MINIMOLEX	Connects to the next board when interconnecting ADM1185 evaluation boards.
J10	6W_MINIMOLEX	Connects to the previous board when interconnecting ADM1185 evaluation boards.

Table 2. Switch Functions

Switch	Description	Position	Function
S1	Switch for powering on and off the board	Switched to 5 V supply	Connects the 5 V rail to the enable input of Regulator 0
		Switched to ground	Grounds the enable input of Regulator 0
S2	Switch for choosing which power supply to connect to the evaluation board	Switched to J1	Connects a 9 V power supply to the evaluation board
		Switched to J3	Connects the bench power supply to the evaluation board
S3	Sets the time delay associated with the 3.3 V input	S3-1 connected to S3-8	Connects C2 (10 nF) between the VIN1 pin and ground
		S3-2 connected to S3-7	Connects C7 (0.1 $\mu$ F) between the VIN1 pin and ground
		S3-3 connected to S3-6	Connects C8 (1 $\mu$ F) between the VIN1 pin and ground
		S3-4 connected to S3-5	Connects C5 and C9 (user defined) between the VIN1 pin and ground
S4	Sets the time delay associated with the 2.5 V input	S4-1 connected to S4-8	Connects C12 (10 nF) between the VIN2 pin and ground
		S4-2 connected to S4-7	Connects C15 (0.1 $\mu$ F) between the VIN2 pin and ground
		S4-3 connected to S4-6	Connects C17 (1 $\mu$ F) between the VIN2 pin and ground
		S4-4 connected to S4-5	Connects C14 and C21 (user defined) between the VIN2 pin and ground
S5	Sets the time delay associated with the 1.8 V input	S5-1 connected to S5-8	Connects C23 (10 nF) between the VIN3 pin and ground
		S5-2 connected to S5-7	Connects C25 (0.1 $\mu$ F) between the VIN3 pin and ground
		S5-3 connected to S5-6	Connects C27 (1 $\mu$ F) between the VIN3 pin and ground
		S5-4 connected to S5-5	Connects C24 and C35 (user defined) between the VIN3 pin and ground
S6	Sets the time delay associated with the 1.5 V input	S6-1 connected to S6-8	Connects C28 (10 nF) between the VIN4 pin and ground
		S6-2 connected to S6-7	Connects C29 (0.1 $\mu$ F) between the VIN4 pin and ground
		S6-3 connected to S6-6	Connects C30 (1 $\mu$ F) between the VIN4 pin and ground
		S6-4 connected to S6-5	Connects C31 and C36 (user defined) between the VIN4 pin and ground
VR1	Rotary switch	N/A	Reduces the 3.3 V supply level when the switch is turned clockwise
VR2	Rotary switch	N/A	Reduces the 2.5 V supply level when the switch is turned clockwise
VR3	Rotary switch	N/A	Reduces the 1.8 V supply level when the switch is turned clockwise
VR4	Rotary switch	N/A	Reduces the 1.5 V supply level when the switch is turned clockwise

Table 3. Jumper Functions

Jumper	Description	Default
J2	Connects J1-1 to J3-1	Input
J4	J4-A: Connects the VCC pin to 3.3 V J4-B: Connects the VCC pin to 5 V J4-C: Connects the VCC pin to VCC_P J4-D: Connects the VCC pin to VCC_N	Input Output Output Output
J5	Connects VR2 to the feedback pin of Regulator U1	Input
J6	Connects VR3 to the feedback pin of Regulator U2	Input
J7	Connects VR4 to the feedback pin of Regulator U3	Input
J8	Connects VR1 to the feedback pin of Regulator U23	Input
J11	J11-A: Connects the VIN1 pin to OUT3_P J11-B: Connects the VIN1 pin to PWRGD_P J11-C: Connects the VIN1 pin to VCC	Output Output Output
J12	J12-A: Connects the PWRGD pin to the PWRGD LED circuitry J12-B: Connects the PWRGD pin to PWRGD_P and is useful when interconnecting evaluation boards	Input Output

Table 4. LED Functions

LED	Name	Function
D1	3.3 V	Yellow LED indicates the status of the 3.3 V supply voltage
D2	2.5 V	Yellow LED indicates the status of the 2.5 V supply voltage
D3	1.8 V	Yellow LED indicates the status of the 1.8 V supply voltage
D4	1.5 V	Yellow LED indicates the status of the 1.5 V supply voltage
D5	PWRGD	Green LED indicates when the PWRGD output is asserted
D6	VCC	Red LED indicates that the board is powered on

Table 5. Test Points

Test Point	Function
VCC	Monitors the voltage at the positive supply input pin
VIN1	Monitors the voltage at Pin VIN1
VIN2	Monitors the voltage at Pin VIN2
VIN3	Monitors the voltage at Pin VIN3
VIN4	Monitors the voltage at Pin VIN4
GND	Monitors the chip ground pin
OUT1	Monitors the voltage at Pin OUT1
OUT2	Monitors the voltage at Pin OUT2
OUT3	Monitors the voltage at Pin OUT3
PWRGD	Monitors the voltage at the PWRGD output
REG1FB	Monitors the feedback pin of Regulator U23
REG1IN	Monitors the input pin of Regulator U23
REG1SD	Monitors the shutdown control pin of Regulator U23
REG2FB	Monitors the feedback pin of Regulator U1
REG2IN	Monitors the input pin of Regulator U1
REG2SD	Monitors the shutdown control pin of Regulator U1
REG3FB	Monitors the feedback pin of Regulator U2
REG3IN	Monitors the input pin of Regulator U2
REG3SD	Monitors the shutdown control pin of Regulator U2
REG4FB	Monitors the feedback pin of Regulator U3
REG4IN	Monitors the input pin of Regulator U3
REG4SD	Monitors the shutdown control pin of Regulator U3

## EVALUATION BOARD OPERATION

### ADM1185 SAMPLES

Two loose ADM1185 samples have been included in the evaluation kit. Place a single sample in the socket before powering on the evaluation board.

### POWERING THE EVALUATION BOARD

There are two methods of powering the EVAL-ADM1185EBZ, by either connecting a 9 V power supply through J3 or by connecting a bench supply through J1 (the 9 V and ground leads must be connected separately). When using a 9 V power supply, ensure to switch S2 to the 9 V position; alternatively, when using a bench supply, switch S2 to the VCC position.

### SETTING VOLTAGE-DETECTION LEVELS

Each of the ADM1185's input pins, VIN1 to VIN4, monitors one of four supply voltages. The VIN1 pin monitors the 3.3 V rail. An external resistor divider scales this voltage down for monitoring at the VIN1 pin. The resistor ratio has been chosen so that the VIN1 voltage is 0.6 V when the main voltage rises to the preferred level at startup. For example, if R1 is 130 k $\Omega$  and R2 is 33 k $\Omega$ , a voltage level of 2.97 V will correspond to 0.6 V at the VIN1 pin, as shown in Figure 2.

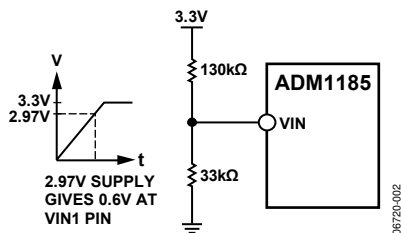

Figure 2. Use of External Resistor Divider to Scale Input Voltage to Appropriate Level

Similar external resistor divider networks have also been implemented on VIN2 to VIN4.

### THEORY OF OPERATION

OUT1 is an open-drain, active high output and is connected to the enable pin of Regulator U1. Before the voltage on VIN1 reaches 0.6 V, OUT1 is switched to ground, disabling the regulator. When

the voltage on pin VIN1 reaches 0.6 V, OUT1 asserts after a 190 ms delay. When this occurs, the open-drain output switches high and the external pull-up resistor pulls the voltage on the regulator enable pin above its turn-on threshold, turning on the output of the regulator.

The 2.5 V output of this regulator begins to rise. This is detected by Input VIN2. When VIN2 sees the 2.5 V rail rise above its threshold point, it asserts OUT2, turning on Regulator U2. The same scheme is, in turn, implemented on the other input and output pins.

After the final supply, 1.5 V turns on, the outputs (OUT1 to OUT3) are logically AND'ed together to generate a system power-good signal (PWRGD). There is an internal 190 ms delay associated with the assertion of the PWRGD output.

### SIMULATING A POWER-UP SEQUENCE

Each of the monitored inputs is adjustable using one of the four rotary switches, VR1 to VR4. By turning each rotary switch clockwise, the associated input voltage is reduced. LEDs provide a visual indication of the status of each of the four inputs and the system PWRGD signal.

Before switching on the power supply, only the red LED, D6, will light up, indicating that a power supply is connected to the board. Begin with all four rotary switches turned fully anticlockwise. Switch the power supply on using Switch S1. Because all four rotary switches are in the anticlockwise position, all four yellow input LEDs, D1 to D4, will light up. After a delay of 190 ms, the green PWRG signal LED, D5, will also light up to indicate that the ADM1185 is in the power-good state.

### OBSERVING FAULT CONDITIONS DURING POWER ON

During power up, the LEDs provide the user with a clear visual indication of each of the four supplies. If one or more of the supply voltages are below their associated threshold voltage, the power-good state is not asserted and the green PWRGD LED is not turned on.

## OBSERVING FAULT CONDITIONS FOLLOWING POWER ON

If all four supply voltages are above their associated threshold, PWRGD asserts and the logical core latches into a different mode of operation. If the 3.3 V supply monitored by VIN1 faults while the device is in the power-good state, the PWRGD output is deasserted and all of the outputs are immediately turned off. If a supply monitored by VIN2 to VIN4 fails, the PWRGD output is deasserted, but the other outputs are not deasserted.

Fault conditions may be investigated by using the four rotary switches, VR1 to VR4. By turning a rotary switch clockwise, the associated input voltage is reduced.

Rotary Switch VR1 controls the voltage at Input VIN1. As VR1 is turned clockwise, this voltage is reduced. When the voltage at Input Pin VIN1 drops below 0.6 V, OUT1 is switched to ground, disabling Regulator U1. In addition, VIN2 can no longer detect the 2.5 V supply and, in turn, OUT2 and OUT3 are deasserted. As a result, the PWRGD output is also deasserted. The LEDs clearly indicate the status of the four voltage supplies and PWRGD.

Similarly, if PWRGD has been asserted and one of the rotary switches, VR2 to VR4, is turned clockwise, reducing the voltage at the associated input pin to below 0.6 V, the PWRGD output is deasserted, but the other outputs are not deasserted. The LEDs provide a clear indication of the status of each of the inputs and PWRGD.

## ADDITIONAL DELAYS

It is possible to introduce additional delays by connecting a capacitor to the input pins, VIN1 to VIN4. For example if a capacitor is placed on the VIN2 pin, the rise of the voltage on that pin will slow, effectively setting a time delay between the 2.5 V rail powering up and the next regulator becoming enabled. Switches S3, S4, S5, and S6 conveniently allow the user to introduce time delays to each of the four inputs.

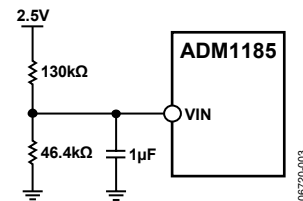

Figure 3. Introduction of Additional Delay

EVALUATION BOARD SCHEMATICS

050720-005

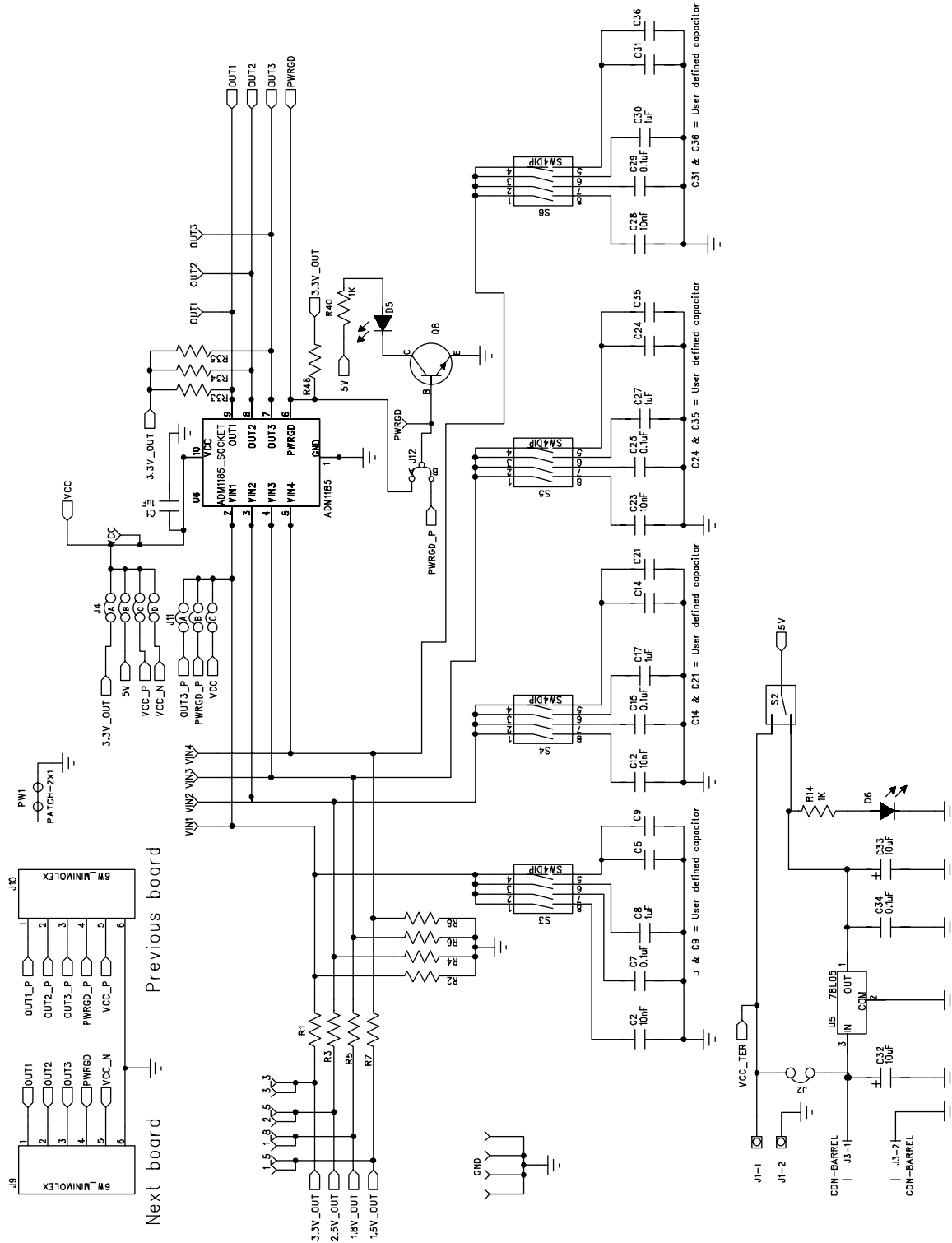

Figure 4. ADM1185 Evaluation Board Schematic, Page 1

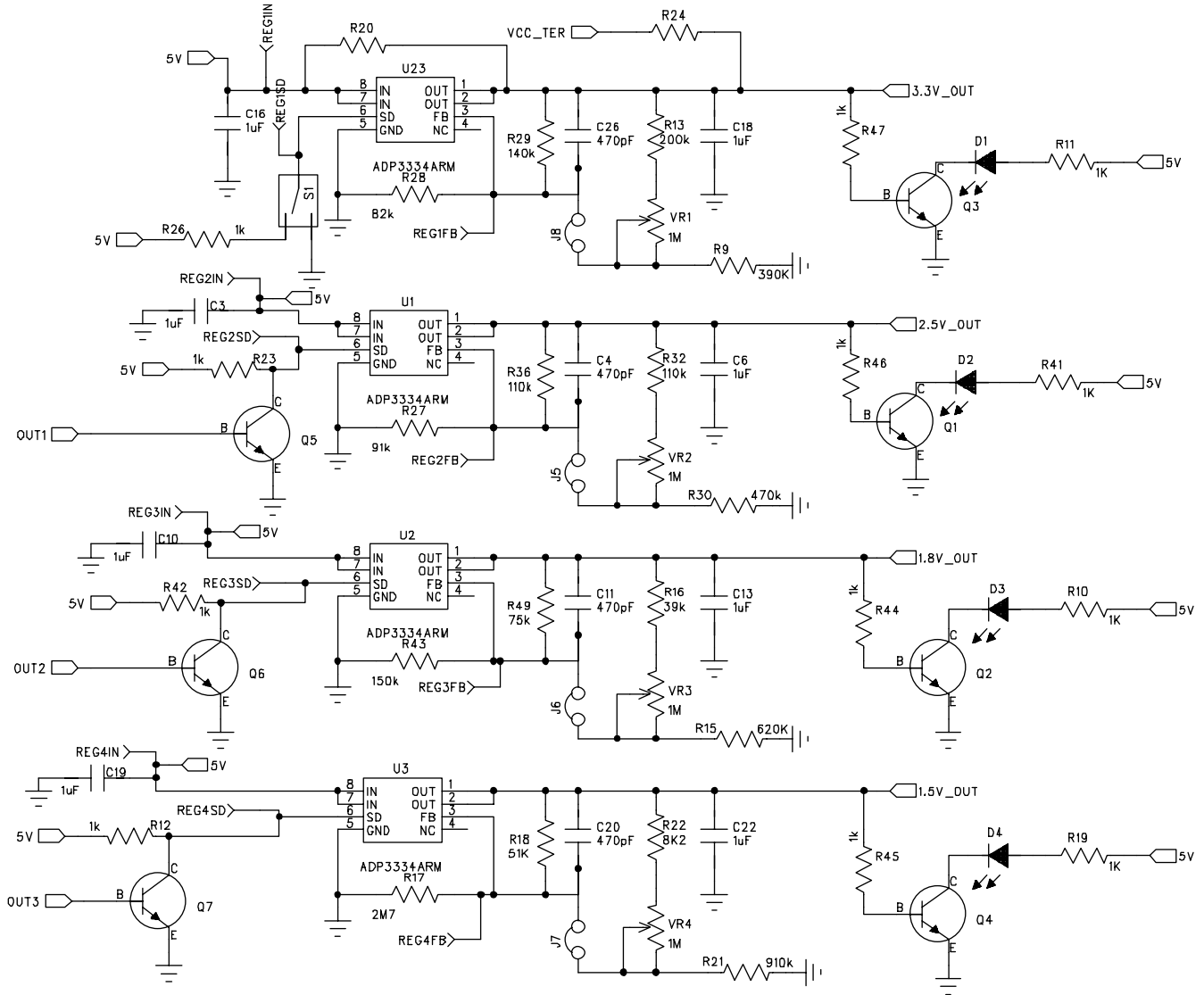

Figure 5. ADM1185 Evaluation Board Schematic, Page 2

06720-005



## ORDERING INFORMATION

## BILL OF MATERIALS

Table 6.

Qty	Reference Designator	Part Type	Value	Part Decal	Part No.
13	C1, C3, C6, C8, C10, C13, C16, C17, C18, C19, C22, C27, C30	Capacitor	1 $\mu$ F	603	FEC 9402080
4	C2, C12, C23, C28	Capacitor	10 nF	603	FEC 753622
3	C4, C11, C26	Capacitor	470 pF	402	FEC 3019366
4	C5, C14, C24, C31	Capacitor	User defined	805	Not Inserted
5	C7, C15, C25, C29, C34	Capacitor	0.1 $\mu$ F	603	FEC 9402047
4	C9, C21, C35, C36	Capacitor	User defined	CAP\MR04	Insert low profile sockets
1	C20	Capacitor	1 $\mu$ F	402	FEC 3019366
1	C32	Capacitor+	10 $\mu$ F	RTAJ_B	FEC 9753893
1	C33	Capacitor+	10 $\mu$ F	RTAJ_B	FEC 197-014
4	R1, R3, R5, R7	Resistor, dual footprint	130 k $\Omega$	0805_thru-hole	FEC 1140363
1	R2	Resistor, dual footprint	33 k $\Omega$	0805_thru-hole	FEC 1108904
1	R4	Resistor, dual footprint	46.4 k $\Omega$	0805_thru-hole	FEC 1160246
1	R6	Resistor, dual footprint	76.8 k $\Omega$	0805_thru-hole	FEC 1141007
1	R8	Resistor, dual footprint	105 k $\Omega$	0805_thru-hole	FEC 1140352
1	R9	Resistor	390 k $\Omega$	805	FEC 9333185
18	R10, R11, R12, R14, R19, R23, R26, R33 to R35, R40 to R42, R44 to R48	Resistor	1 k $\Omega$	805	FEC 9332383
1	R13	Resistor	200 k $\Omega$	805	FEC 9332782
1	R15	Resistor	620 k $\Omega$	805	FEC 9333444
1	R16	Resistor	39 k $\Omega$	805	FEC 9333177
1	R17	Resistor	220 k $\Omega$	805	FEC 9332839
1	R18	Resistor	62 k $\Omega$	805	FEC 9333436
2	R20, R24	Resistor 1210	N/A	1210	N/A
1	R21	Resistor	910 k $\Omega$	805	FEC 9333657
1	R22	Resistor	1.8 k $\Omega$	805	FEC 9332715
1	R27	Resistor	100 k $\Omega$	805	FEC 9332405
1	R28	Resistor	76.8 k $\Omega$	805	FEC 1141007
2	R29, R43	Resistor	140 k $\Omega$	805	FEC 1160268
1	R30	Resistor	470 k $\Omega$	805	FEC 9333282
2	R32, R36	Resistor	110 k $\Omega$	805	FEC 9332464
1	R49	Resistor	75 k $\Omega$	805	FEC 9333541
4	D1, D2, D3, D4	LED yellow		LED-0805	FEC 1021303
1	D5	LED green		LED-0805	FEC 5790852
1	D6	LED red		LED-0805	FEC1058373
1	S1	SW-SPDT-SLIDE		SW-SPDT-SLIDE	FEC 1123875
1	S2	SW-SPDT-SLIDE		SW-SPDT-SLIDE	FEC 1123876
4	S3, S4, S5, S6	SW\4DIP		DIP8_SMD	FEC 9901868
1	J1	CON\power		CON\power	FEC 151785
2	J2, J12	Jumper		SIP-2P	FEC 1022247 and 150411
1	J3	CON\barrel		CON\barrel	FEC 224959
1	J4	Jumper-4		Jumper_4_ABCD	
4	J5, J6, J7, J8	Jumper		SIP-2P	FEC 1022247 and 150411
2	J9, J10	6W_MINIMOLEX		MOLEX53398-0690	FEC 1125368

Qty	Reference Designator	Part Type	Value	Part Decal	Part No.
1	J11	Jumper-3		Jumper_3	FEC 102-2244 (36-pin strip) and 150-411
8	Q1, Q2, Q3, Q4, Q5, Q6, Q7, Q8	BC850B		SOT23	FEC 1081239
4	U1, U2, U3, U23	ADP3334ARMZ		MSO8	Free, issued by Analog Devices
1	U4	ADM1185ARMZ		MSO10	ADM1185ARMZ
1	U5	MC78L05ACZ		TO-92	FEC 9489444
1	U6	ADM1185 socket		MSO10-SKT	Abrel Products 6560102211
4	VR1, VR2, VR3, VR4	VRES_rotary		VRES_rotary	FEC 9608290
4	GND, GND1, GND2, GND3	Test point		Test point	FEC 8731128
29	OUT1, OUT2, OUT3, PWRGD, VCC, VIN1, VIN2, VIN3, VIN4, REG1FB, REG1IN, REG1SD, REG2FB, REG2IN, REG2SD, REG3FB, REG3IN, REG3SD, REG4FB, REG4IN, REG4SD, 1_1, 1_2, 1_3, 1_4, 1_5, 1_8, 2_5, 3_3	Test point		Test point	FEC 8731144

## ORDERING GUIDE

Model	Description
EVAL-ADM1185EBZ <sup>1</sup>	ADM1185 Main Evaluation Kit

<sup>1</sup> Z = RoHS Compliant Part.

## ESD CAUTION



**ESD (electrostatic discharge) sensitive device.** Charged devices and circuit boards can discharge without detection. Although this product features patented or proprietary protection circuitry, damage may occur on devices subjected to high energy ESD. Therefore, proper ESD precautions should be taken to avoid performance degradation or loss of functionality.

**NOTES**

**NOTES**