



MICROCHIP

MIC4802
Evaluation Board
User's Guide

Note the following details of the code protection feature on Microchip devices:

- Microchip products meet the specification contained in their particular Microchip Data Sheet.
- Microchip believes that its family of products is one of the most secure families of its kind on the market today, when used in the intended manner and under normal conditions.
- There are dishonest and possibly illegal methods used to breach the code protection feature. All of these methods, to our knowledge, require using the Microchip products in a manner outside the operating specifications contained in Microchip's Data Sheets. Most likely, the person doing so is engaged in theft of intellectual property.
- Microchip is willing to work with the customer who is concerned about the integrity of their code.
- Neither Microchip nor any other semiconductor manufacturer can guarantee the security of their code. Code protection does not mean that we are guaranteeing the product as "unbreakable."

Code protection is constantly evolving. We at Microchip are committed to continuously improving the code protection features of our products. Attempts to break Microchip's code protection feature may be a violation of the Digital Millennium Copyright Act. If such acts allow unauthorized access to your software or other copyrighted work, you may have a right to sue for relief under that Act.

Information contained in this publication regarding device applications and the like is provided only for your convenience and may be superseded by updates. It is your responsibility to ensure that your application meets with your specifications. MICROCHIP MAKES NO REPRESENTATIONS OR WARRANTIES OF ANY KIND WHETHER EXPRESS OR IMPLIED, WRITTEN OR ORAL, STATUTORY OR OTHERWISE, RELATED TO THE INFORMATION, INCLUDING BUT NOT LIMITED TO ITS CONDITION, QUALITY, PERFORMANCE, MERCHANTABILITY OR FITNESS FOR PURPOSE. Microchip disclaims all liability arising from this information and its use. Use of Microchip devices in life support and/or safety applications is entirely at the buyer's risk, and the buyer agrees to defend, indemnify and hold harmless Microchip from any and all damages, claims, suits, or expenses resulting from such use. No licenses are conveyed, implicitly or otherwise, under any Microchip intellectual property rights unless otherwise stated.

Microchip received ISO/TS-16949:2009 certification for its worldwide headquarters, design and wafer fabrication facilities in Chandler and Tempe, Arizona; Gresham, Oregon and design centers in California and India. The Company's quality system processes and procedures are for its PIC[®] MCUs and dsPIC[®] DSCs, KEELoC[®] code hopping devices, Serial EEPROMs, microperipherals, nonvolatile memory and analog products. In addition, Microchip's quality system for the design and manufacture of development systems is ISO 9001:2000 certified.

**QUALITY MANAGEMENT SYSTEM
CERTIFIED BY DNV
= ISO/TS 16949 =**

Trademarks

The Microchip name and logo, the Microchip logo, AnyRate, AVR, AVR logo, AVR Freaks, BeaconThings, BitCloud, chipKIT, chipKIT logo, CryptoMemory, CryptoRF, dsPIC, FlashFlex, flexPWR, Heldo, JukeBlox, KEELoQ, KEELoQ logo, Klear, LANCheck, LINK MD, maXStylus, maXTouch, MediaLB, megaAVR, MOST, MOST logo, MPLAB, OptoLyzer, PIC, picoPower, PICSTART, PIC32 logo, Prochip Designer, QTouch, RightTouch, SAM-BA, SpyNIC, SST, SST Logo, SuperFlash, tinyAVR, UNI/O, and XMEGA are registered trademarks of Microchip Technology Incorporated in the U.S.A. and other countries.

ClockWorks, The Embedded Control Solutions Company, EtherSynch, Hyper Speed Control, HyperLight Load, IntelliMOS, mTouch, Precision Edge, and Quiet-Wire are registered trademarks of Microchip Technology Incorporated in the U.S.A.

Adjacent Key Suppression, AKS, Analog-for-the-Digital Age, Any Capacitor, AnyIn, AnyOut, BodyCom, CodeGuard, CryptoAuthentication, CryptoCompanion, CryptoController, dsPICDEM, dsPICDEM.net, Dynamic Average Matching, DAM, ECAN, EtherGREEN, In-Circuit Serial Programming, ICSP, Inter-Chip Connectivity, JitterBlocker, KlearNet, KlearNet logo, Mindi, MiWi, motorBench, MPASM, MPF, MPLAB Certified logo, MPLIB, MPLINK, MultiTRAK, NetDetach, Omniscient Code Generation, PICDEM, PICDEM.net, PICKit, PICTail, PureSilicon, QMatrix, RightTouch logo, REAL ICE, Ripple Blocker, SAM-ICE, Serial Quad I/O, SMART-I.S., SQI, SuperSwitcher, SuperSwitcher II, Total Endurance, TSHARC, USBCheck, VariSense, ViewSpan, WiperLock, Wireless DNA, and ZENA are trademarks of Microchip Technology Incorporated in the U.S.A. and other countries.

SQTP is a service mark of Microchip Technology Incorporated in the U.S.A.

Silicon Storage Technology is a registered trademark of Microchip Technology Inc. in other countries.

GestIC is a registered trademark of Microchip Technology Germany II GmbH & Co. KG, a subsidiary of Microchip Technology Inc., in other countries.

All other trademarks mentioned herein are property of their respective companies.

© 2018, Microchip Technology Incorporated, All Rights Reserved.
ISBN: 978-1-5224-3312-5

Table of Contents

Preface	5
Introduction.....	5
Document Layout	5
Conventions Used in this Guide	6
Recommended Reading.....	7
The Microchip Website.....	7
Product Change Notification Service.....	7
Customer Support	7
Document Revision History	7
Chapter 1. Product Overview	
1.1 Introduction	9
1.2 MIC4802 Short Overview	9
1.2.1 MIC4802 Key Features	9
1.2.2 MIC4802 Device Overview	9
1.3 MIC4802 Evaluation Board Description	10
1.4 MIC4802 Evaluation Board Kit Contents	10
Chapter 2. Installation and Operation	
2.1 Introduction	11
2.2 Evaluation Board Description	12
2.2.1 Current Set Resistor (R4)	12
2.2.2 Enable/PWM Feature (JP1)	12
2.2.3 D1 – LED Cathode (J6)	15
2.2.4 Output Noise and Ripple Measurements	15
2.2.5 Board Layout Considerations	15
Appendix A. Schematic and Layouts	
A.1 Introduction	17
A.2 Board – Schematic	18
A.3 Board – Top Silk Layer	19
A.4 Board – Top Copper and Silk Layer	20
A.5 Board – Top Copper Layer	21
A.6 Board – Bottom Copper Layer	22
A.7 Board – Bottom Copper and Silk Layer	23
A.8 Board – Bottom Silk Layer	24
Appendix B. Bill of Materials (BOM)	
Worldwide Sales and Service	27



Preface

NOTICE TO CUSTOMERS

All documentation becomes dated, and this manual is no exception. Microchip tools and documentation are constantly evolving to meet customer needs, so some actual dialogs and/or tool descriptions may differ from those in this document. Please refer to our website (www.microchip.com) to obtain the latest documentation available.

Documents are identified with a “DS” number. This number is located on the bottom of each page, in front of the page number. The numbering convention for the DS number is “DSXXXXXXXXA”, where “XXXXXXXX” is the document number and “A” is the revision level of the document.

For the most up-to-date information on development tools, see the MPLAB® IDE online help. Select the Help menu, and then Topics, to open a list of available online help files.

INTRODUCTION

This chapter contains general information that will be useful to know before using the MIC4802 Evaluation Board. Items discussed in this chapter include:

- [Document Layout](#)
- [Conventions Used in this Guide](#)
- [Recommended Reading](#)
- [The Microchip Website](#)
- [Customer Support](#)
- [Document Revision History](#)

DOCUMENT LAYOUT

This document describes how to use the MIC4802 Evaluation Board as a development tool. The manual layout is as follows:

- **Chapter 1. “Product Overview”** – Important information about the MIC4802 Evaluation Board.
- **Chapter 2. “Installation and Operation”** – This chapter includes a detailed description of each function of the demonstration board and instructions for how to begin using the MIC4802 Evaluation Board.
- **Appendix A. “Schematic and Layouts”** – Shows the schematic and PCB layout diagrams for the MIC4802 Evaluation Board.
- **Appendix B. “Bill of Materials (BOM)”** – Lists the parts used to build the MIC4802 Evaluation Board.

MIC4802 Evaluation Board User's Guide

CONVENTIONS USED IN THIS GUIDE

This manual uses the following documentation conventions:

DOCUMENTATION CONVENTIONS

Description	Represents	Examples
Arial font:		
Italic characters	Referenced books	<i>MPLAB[®] IDE User's Guide</i>
	Emphasized text	...is the <i>only</i> compiler...
Initial caps	A window	the Output window
	A dialog	the Settings dialog
	A menu selection	select Enable Programmer
Quotes	A field name in a window or dialog	"Save project before build"
Underlined, italic text with right angle bracket	A menu path	<u><i>File</i></u> >Save
Bold characters	A dialog button	Click OK
	A tab	Click the Power tab
N'Rnnnn	A number in verilog format, where N is the total number of digits, R is the radix and n is a digit.	4'b0010, 2'hF1
Text in angle brackets < >	A key on the keyboard	Press <Enter>, <F1>
Courier New font:		
Plain Courier New	Sample source code	#define START
	Filenames	autoexec.bat
	File paths	c:\mcc18\h
	Keywords	_asm, _endasm, static
	Command-line options	-Opa+, -Opa-
	Bit values	0, 1
	Constants	0xFF, 'A'
Italic Courier New	A variable argument	<i>file.o</i> , where <i>file</i> can be any valid filename
Square brackets []	Optional arguments	mcc18 [options] <i>file</i> [options]
Curly brackets and pipe character: { }	Choice of mutually exclusive arguments; an OR selection	errorlevel {0 1}
Ellipses...	Replaces repeated text	var_name [, var_name...]
	Represents code supplied by user	void main (void) { ... }

RECOMMENDED READING

This user's guide describes how to use the MIC4802 Evaluation Board. Other useful documents are listed below. The following Microchip document is available and recommended as a supplemental reference resource:

- **MIC4802 Data Sheet** – *“High Efficiency 800mA Single Channel Linear WLED Driver with Ultra Fast PWM™ Control”* (M9999-013111-B)

THE MICROCHIP WEBSITE

Microchip provides online support via our website at www.microchip.com. This website is used as a means to make files and information easily available to customers. Accessible by using your favorite Internet browser, the website contains the following information:

- **Product Support** – Data sheets and errata, application notes and sample programs, design resources, user's guides and hardware support documents, latest software releases and archived software
- **General Technical Support** – Frequently Asked Questions (FAQs), technical support requests, online discussion groups, Microchip consultant program member listing
- **Business of Microchip** – Product selector and ordering guides, latest Microchip press releases, listing of seminars and events, listings of Microchip sales offices, distributors and factory representatives

PRODUCT CHANGE NOTIFICATION SERVICE

Microchip's customer notification service helps keep customers current on Microchip products. Subscribers will receive e-mail notifications whenever there are changes, updates, revisions or errata related to a specified product family or development tool of interest.

To register, access the Microchip website at www.microchip.com, click on **Product Change Notification** and follow the registration instructions.

CUSTOMER SUPPORT

Users of Microchip products can receive assistance through several channels:

- Distributor or Representative
- Local Sales Office
- Field Application Engineer (FAE)
- Technical Support

Customers should contact their distributor, representative or field application engineer (FAE) for support. Local sales offices are also available to help customers. A listing of sales offices and locations is included in the back of this document.

Technical support is available through the website at:
<http://www.microchip.com/support>.

DOCUMENT REVISION HISTORY

Revision A (July 2018)

- Initial release of this document.

MIC4802 Evaluation Board User's Guide

NOTES:

Chapter 1. Product Overview

1.1 INTRODUCTION

This chapter provides an overview of the MIC4802 Evaluation Board and covers the following topics:

- [MIC4802 Short Overview](#)
- [MIC4802 Evaluation Board Description](#)
- [MIC4802 Evaluation Board Kit Contents](#)

1.2 MIC4802 SHORT OVERVIEW

1.2.1 MIC4802 Key Features

The key features of the MIC4802 include:

- 3.0V to 5.5V input voltage range
- Ultra Fast Pulse-width Modulation (PWM) control (200 Hz to 500 kHz)
- Dropout of 280 mV at 800 mA
- Programmable LED current with external resistor
- Current accuracy of 1% typical
- LED driver voltage range 0V to V_{IN}
- Enable input voltage range 0V to V_{IN}
- -40°C to +125°C junction temperature range

1.2.2 MIC4802 Device Overview

The MIC4802 is a high efficiency White LED (WLED) linear driver designed to drive a single LED up to 800 mA. The MIC4802 provides the highest possible efficiency, as this architecture has no switching losses present in traditional charge pumps or inductive boost circuits. It features a typical dropout of 280 mV at 800 mA. This allows the LEDs to be driven directly from the voltage source eliminating switching noise/losses present with the use of boost circuitry. The high accuracy (1% Typical) current regulated WLED channel ensures uniform display illumination under all conditions. The brightness is controlled through an Ultra Fast PWM Control interface operating down to less than 1% duty cycle.

The 3.0V to 5.5V input voltage range of MIC4802 allows direct operation from one cell Li-Ion as 3 to 4 cell Ni-Cd, Ni-MH or Alkaline batteries. Maximum battery life is assured with a low 0.01 μ A typical shutdown current.

MIC4802 Evaluation Board User's Guide

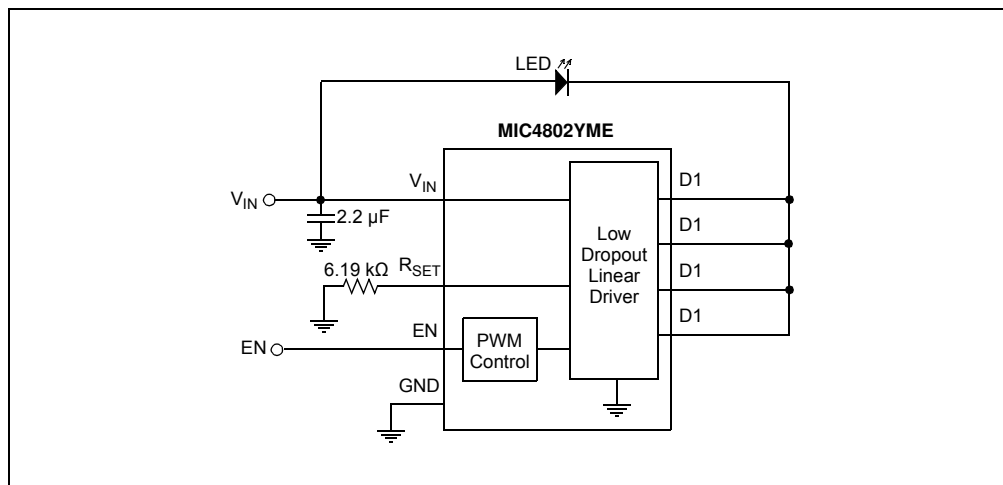

FIGURE 1-1: MIC4802 Typical Application.

1.3 MIC4802 EVALUATION BOARD DESCRIPTION

The board is populated with the MIC4802YME device and uses a high power white LED as a load. The MIC4802 Evaluation Board has been developed to evaluate a typical application, where V_{IN} is between 3.0V to 5.5V and current through LED is fixed to 600 mA.

The MIC4802 Evaluation Board features an independent Enable connector (JP1). To disable the LED driver, it is necessary to insert a jumper in the JP1 header. Since it's not recommended to leave the EN pin floating, the MIC4802 Evaluation Board features a 10 k Ω pull-up resistor to V_{IN} , so the default value when the board is powered is ON. The EN pin can also be used as a PWM input for dimming the LED brightness. The PWM signal must be between 200 Hz and 500 kHz.

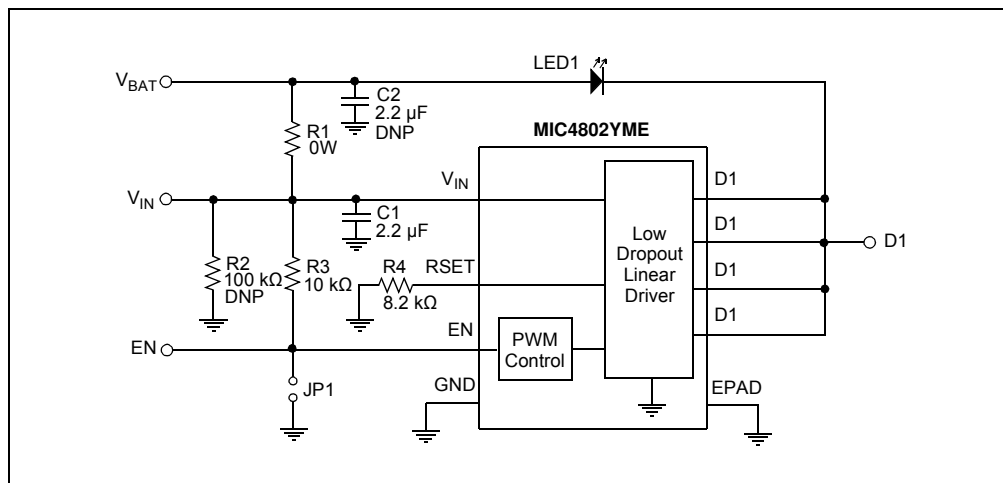

FIGURE 1-2: MIC4802 Evaluation Board – Schematic.

1.4 MIC4802 EVALUATION BOARD KIT CONTENTS

The MIC4802 Evaluation Board kit includes:

- MIC4802 Evaluation Board (ADM00942)
- Information Sheet

Chapter 2. Installation and Operation

2.1 INTRODUCTION

MIC4802 is a high efficiency linear White LED driver designed to drive a single LED up to 800 mA.

MIC4802 is a constant current driver designed to drive high power LEDs in various lighting applications. The MIC4802 provides the highest possible efficiency as this architecture has no switching losses present in traditional charge pumps or inductive boost circuits. It features a typical dropout of 280 mV at 800 mA load. This allows the LEDs to be driven directly from the voltage supply without the switching noise that is present for switching solutions.

The MIC4802 Evaluation Board can be powered from 3.0V to 5.5V range and the LED current is fixed at 600 mA through resistor R4.

An external high power LED can be connected between V_{BAT} (with anode) and D1 (with cathode) terminals in order to evaluate the MIC4802 at maximum performance (800 mA). To do so, it is necessary to remove the Evaluation Board LED and modify the R4 from 8.2 k Ω (600 mA) to 6.19 k Ω (800 mA).

To power up the MIC4802 Evaluation Board, the following steps must be completed:

1. Connect an external supply between V_{IN} and GND terminals. Pay attention to the polarity.
2. With the output of the power supply disabled, set its voltage to the desired input test voltage ($3.0V \leq V_{IN} \leq 5.5V$). An ammeter may be placed between the input supply and the V_{IN} terminals. Be sure to monitor the supply voltage at the V_{IN} terminal, as the ammeter and/or power lead resistance can reduce the voltage supplied to the device.
3. Connect a voltmeter between D1 and V_{BAT} terminals to measure the LED drop voltage.

The MIC4802 Evaluation Board has a pull-up resistor to V_{IN} . By default, the output voltage will be enabled when the input supply of >3.0V is applied. To disable the device, apply a voltage of 1.2V to V_{IN} to enable the regulator, or 0.2V to GND to disable the EN terminal (JP1).

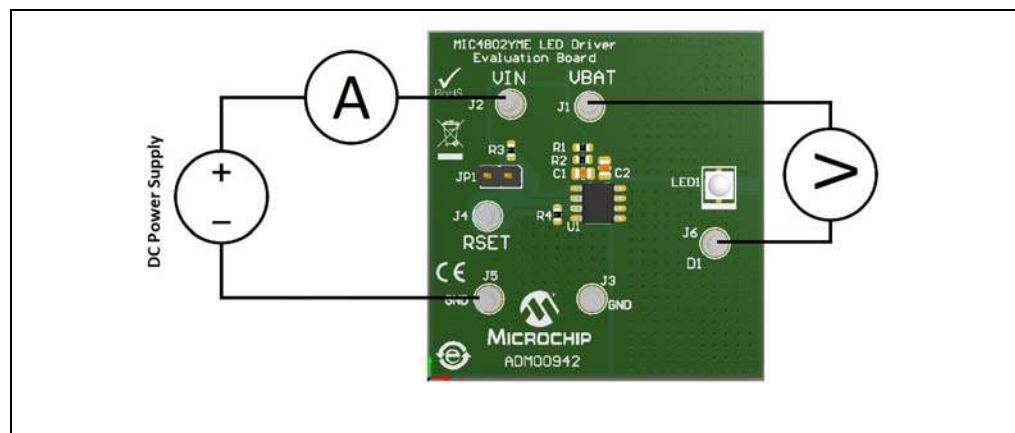

FIGURE 2-1: MIC4802 Evaluation Board – Test Circuit.

MIC4802 Evaluation Board User's Guide

2.2 EVALUATION BOARD DESCRIPTION

2.2.1 Current Set Resistor (R4)

The MIC4802 has a programmable LED current which is dependent by the R_{SET} value. The R_{SET} pin is used to set the peak current of the linear driver by connecting a R_{SET} resistor to ground. The theoretical average LED current can be estimated by applying Equation 2-1.

EQUATION 2-1:

$$I_{LED}(mA) = \frac{4920 \times D}{R_{SET}(k\Omega)}$$

$$R_{SET}(mA) = \frac{4920 \times D}{I_{LED}(mA)}$$

'D' is the duty cycle of the LED current during PWM dimming. When the device is fully ON, the duty cycle equals 100% (D = 1).

2.2.2 Enable/PWM Feature (JP1)

The EN pin is equivalent to the enable pin for the linear drivers on the MI4802. It can also be used for dimming by applying a PWM signal, as shown in the following scope shots. Pulling the EN low for more than 40 ms puts the MIC4802 into a low IQ sleep mode. The EN pin cannot be left floating because a floating enable pin may cause an indeterminate state on the outputs. The first pulse on the EN pin must be equal or greater than 60 μ s to wake the part up in a known state. This equals to an 8.3 kHz PWM signal at equal or greater than 50% duty cycle. Higher PWM frequencies may be used, but the first pulse must be equal or greater than 60 μ s.

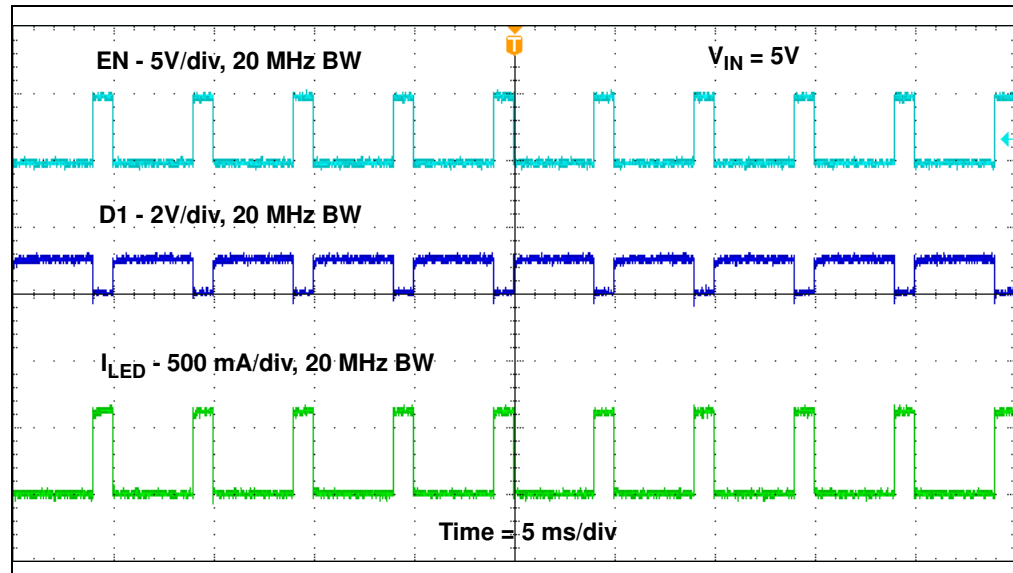

FIGURE 2-2: MIC4802 at 20% Duty Cycle.

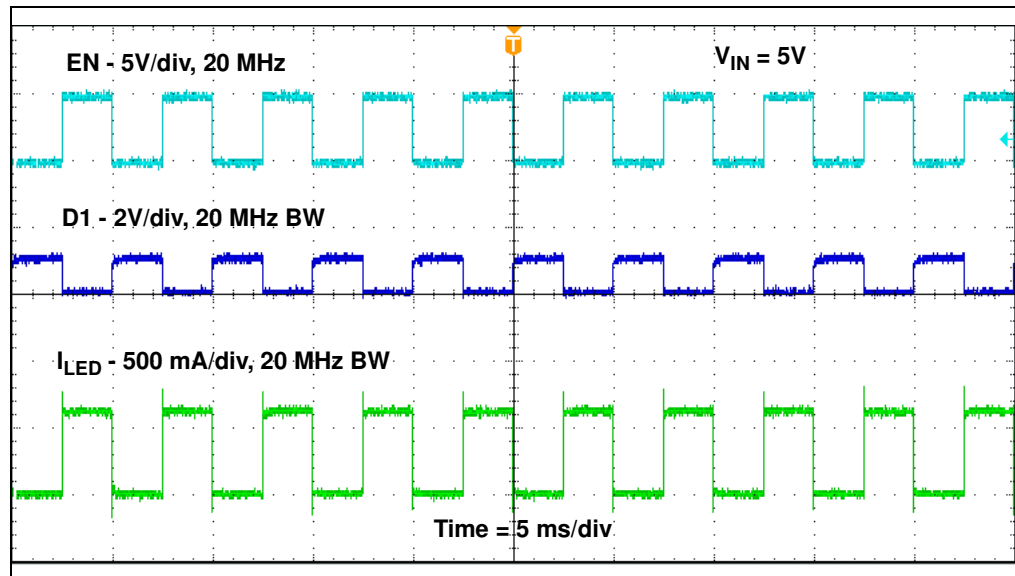

FIGURE 2-3: MIC4802 at 50% Duty Cycle.

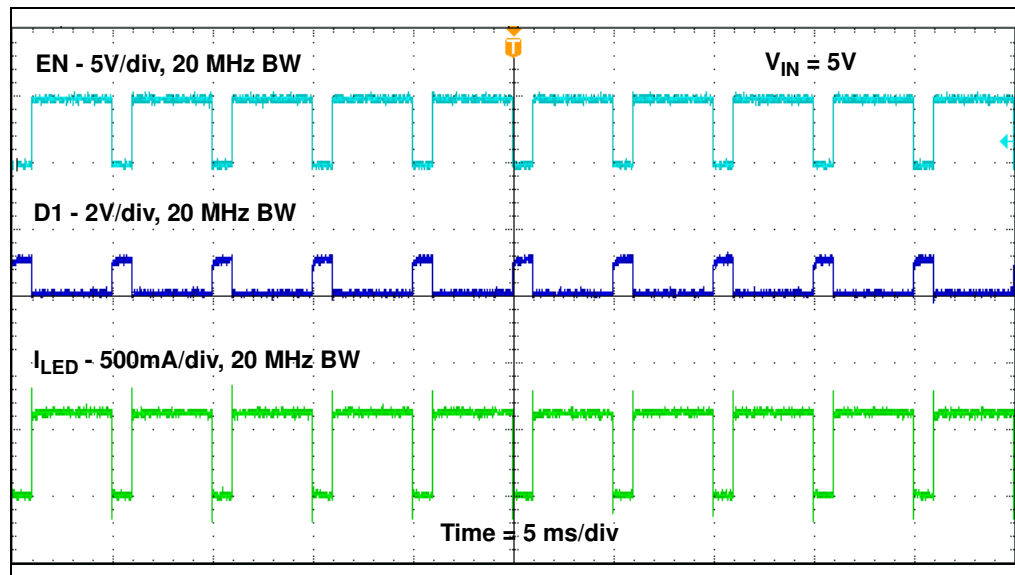

FIGURE 2-4: MIC4802 at 80% Duty Cycle.

MIC4802 Evaluation Board User's Guide

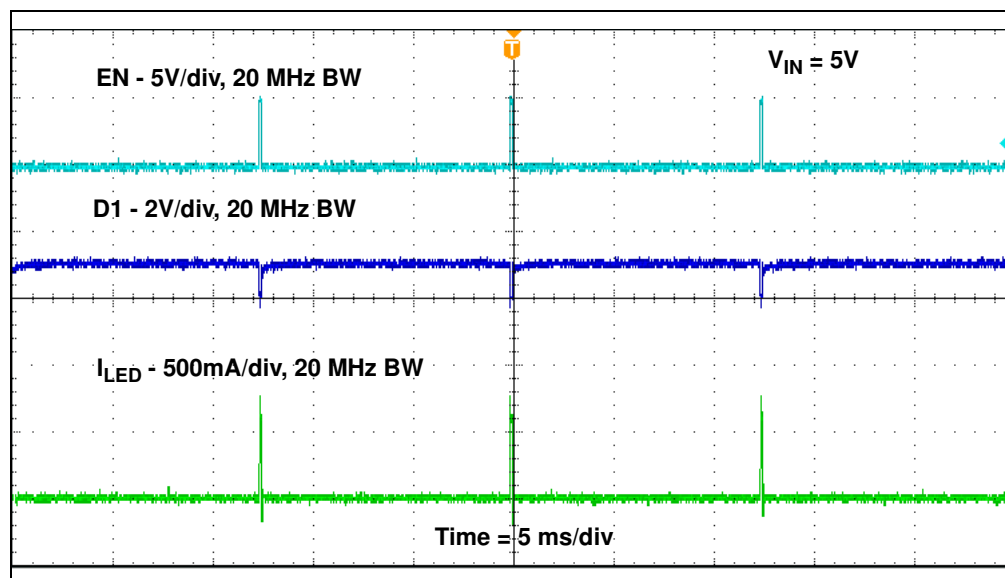

FIGURE 2-5: MIC4802 at 1% Duty Cycle.

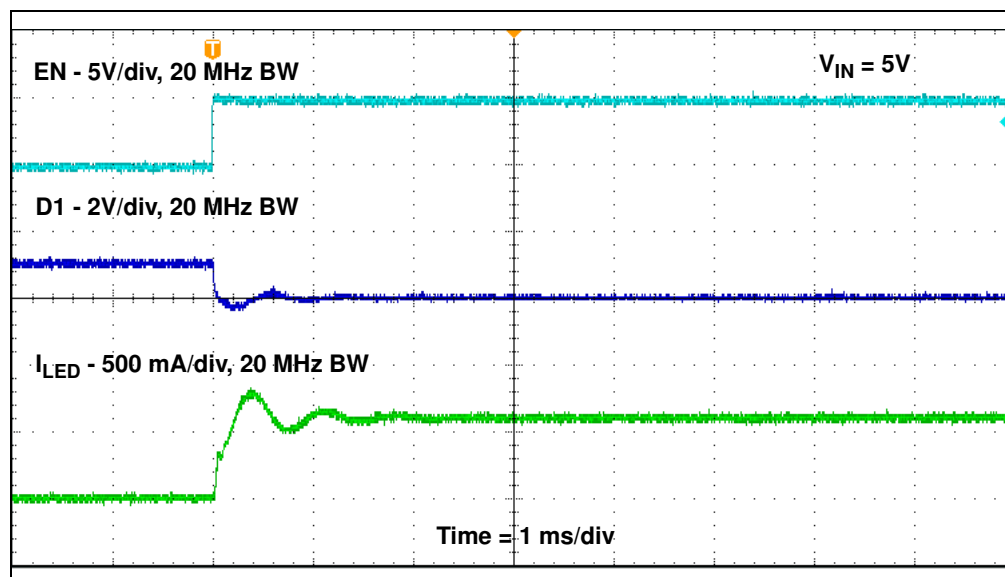

FIGURE 2-6: MIC4802 Stand-by to ON Transition.

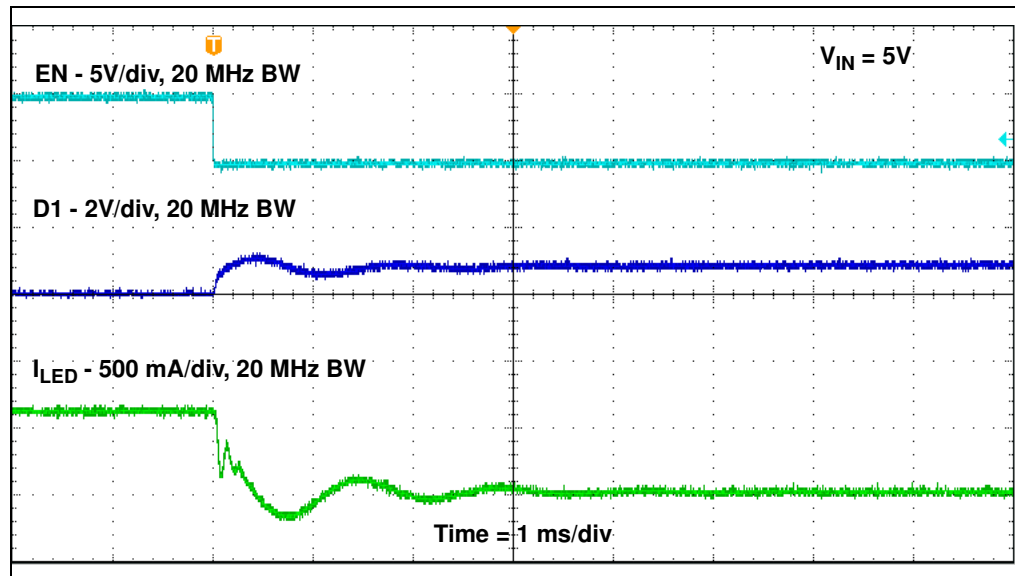

FIGURE 2-7: MIC4802 ON to Stand-by Transition.

2.2.3 D1 – LED Cathode (J6)

The D1 pins are the linear inputs for the LED. The anode of the LED is connected to V_{IN} potential and the LED cathode is connected to the D1 pins. All the D1 pins must be connected together. The D1 voltage at dropout is the minimum voltage required by the linear driver in order for the LED to be fully biased.

2.2.4 Output Noise and Ripple Measurements

To properly measure voltage ripple on either the input or output of any regulator, a proper ring-in tip measurement is required. Standard oscilloscope probes come with a grounding clip, or a long wire with an alligator clip. Unfortunately, for high-frequency measurements, this ground clip can pick up high frequency noise and erroneously inject it into the measured output ripple.

2.2.5 Board Layout Considerations

It is recommended that a copper plane is placed immediately under the MIC4802 and it must be connected to the GND copper plane using a via under the device. As the MIC4802 has an exposed pad, the copper plane will help conduct the heat away from the device and improve thermal performance. Moreover, doing this will also help shield the device and improve output ripple performance.

MIC4802 Evaluation Board User's Guide

NOTES:

Appendix A. Schematic and Layouts

A.1 INTRODUCTION

This appendix contains the following schematics and layouts for the MIC4802 Evaluation Board:

- [Board – Schematic](#)
- [Board – Top Silk Layer](#)
- [Board – Top Copper and Silk Layer](#)
- [Board – Top Copper Layer](#)
- [Board – Bottom Copper Layer](#)
- [Board – Bottom Copper and Silk Layer](#)
- [Board – Bottom Silk Layer](#)

A.2 BOARD – SCHEMATIC

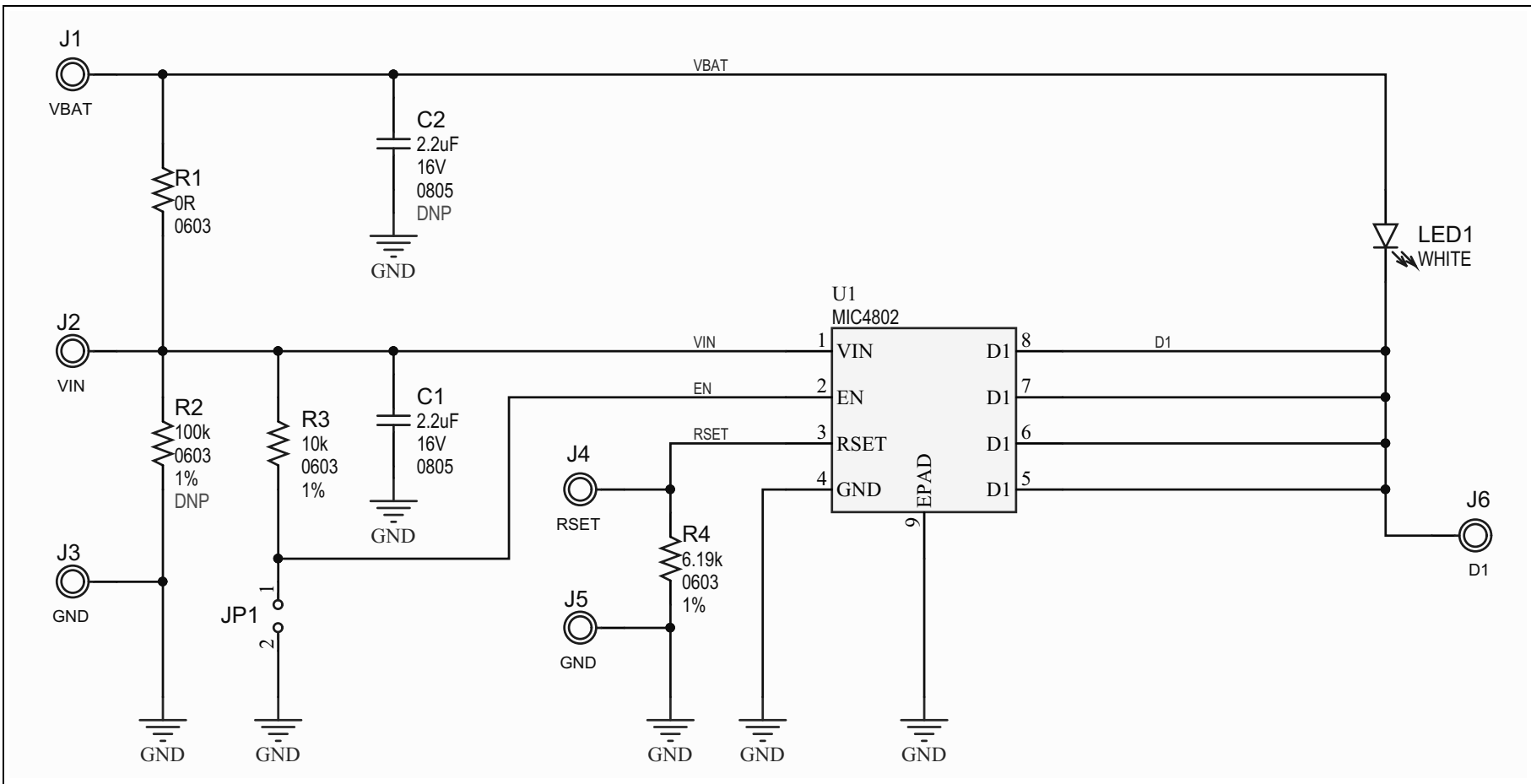

A.3 BOARD – TOP SILK LAYER

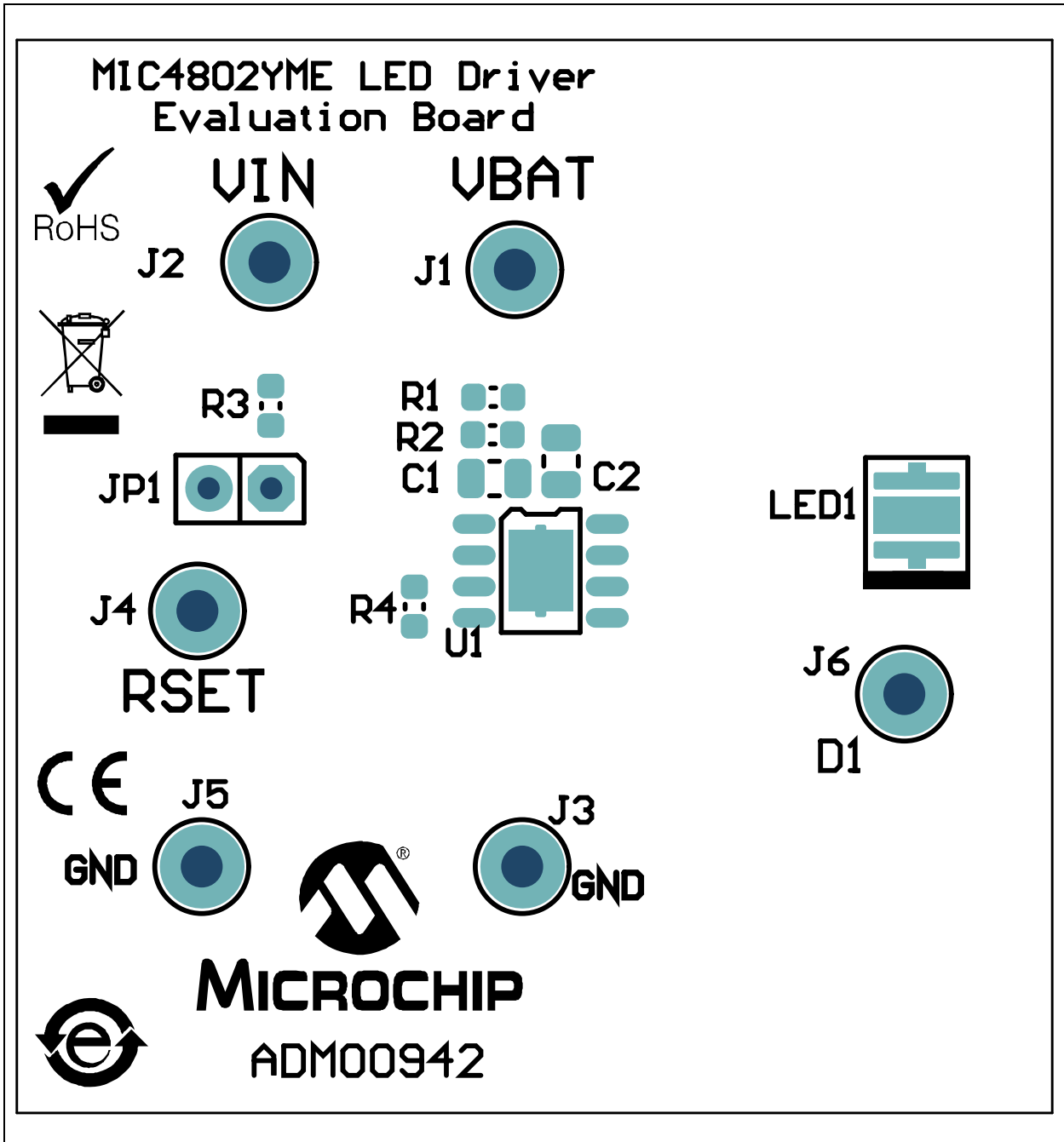

MIC4802 Evaluation Board User's Guide

A.4 BOARD – TOP COPPER AND SILK LAYER

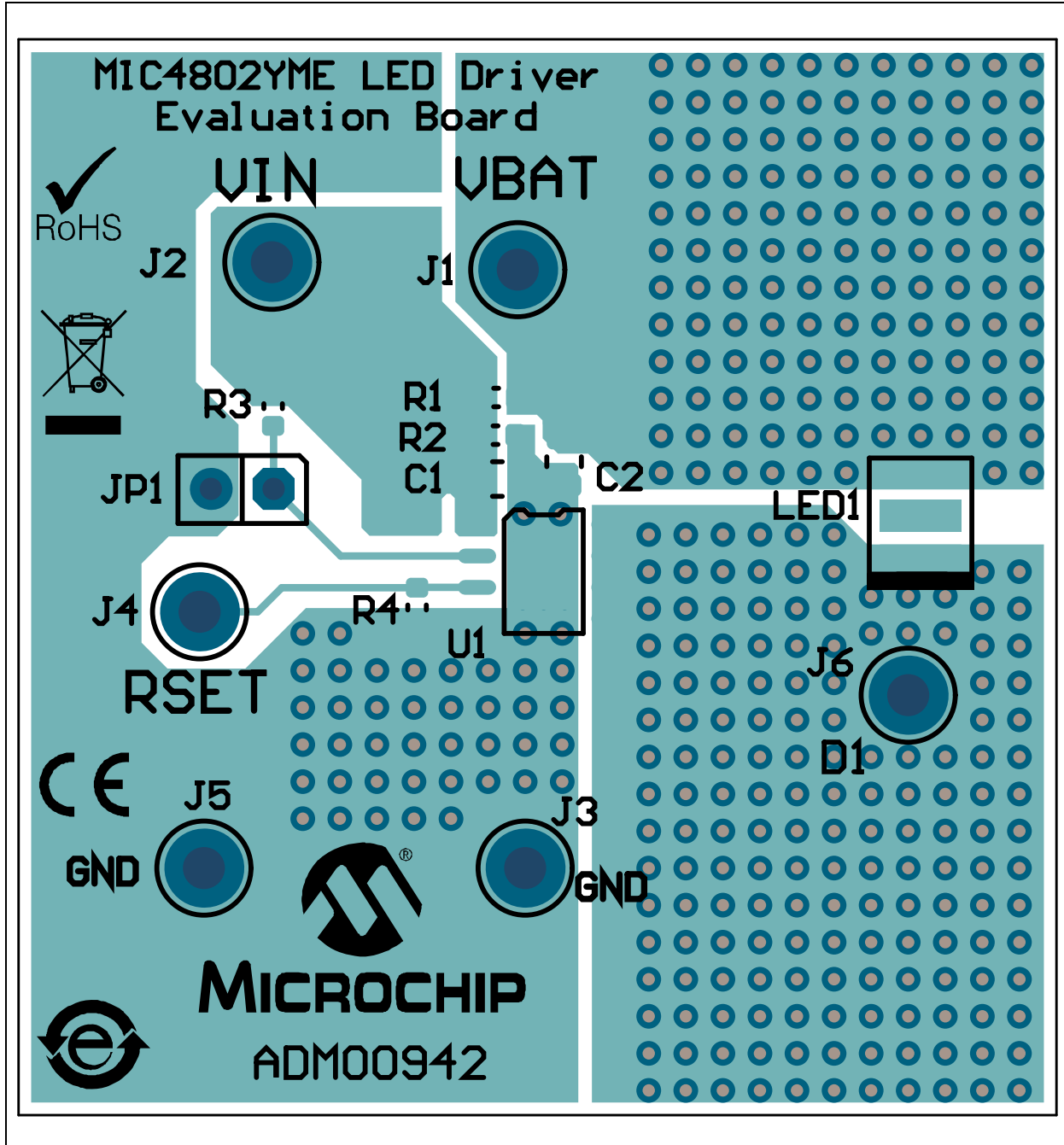

A.5 BOARD – TOP COPPER LAYER

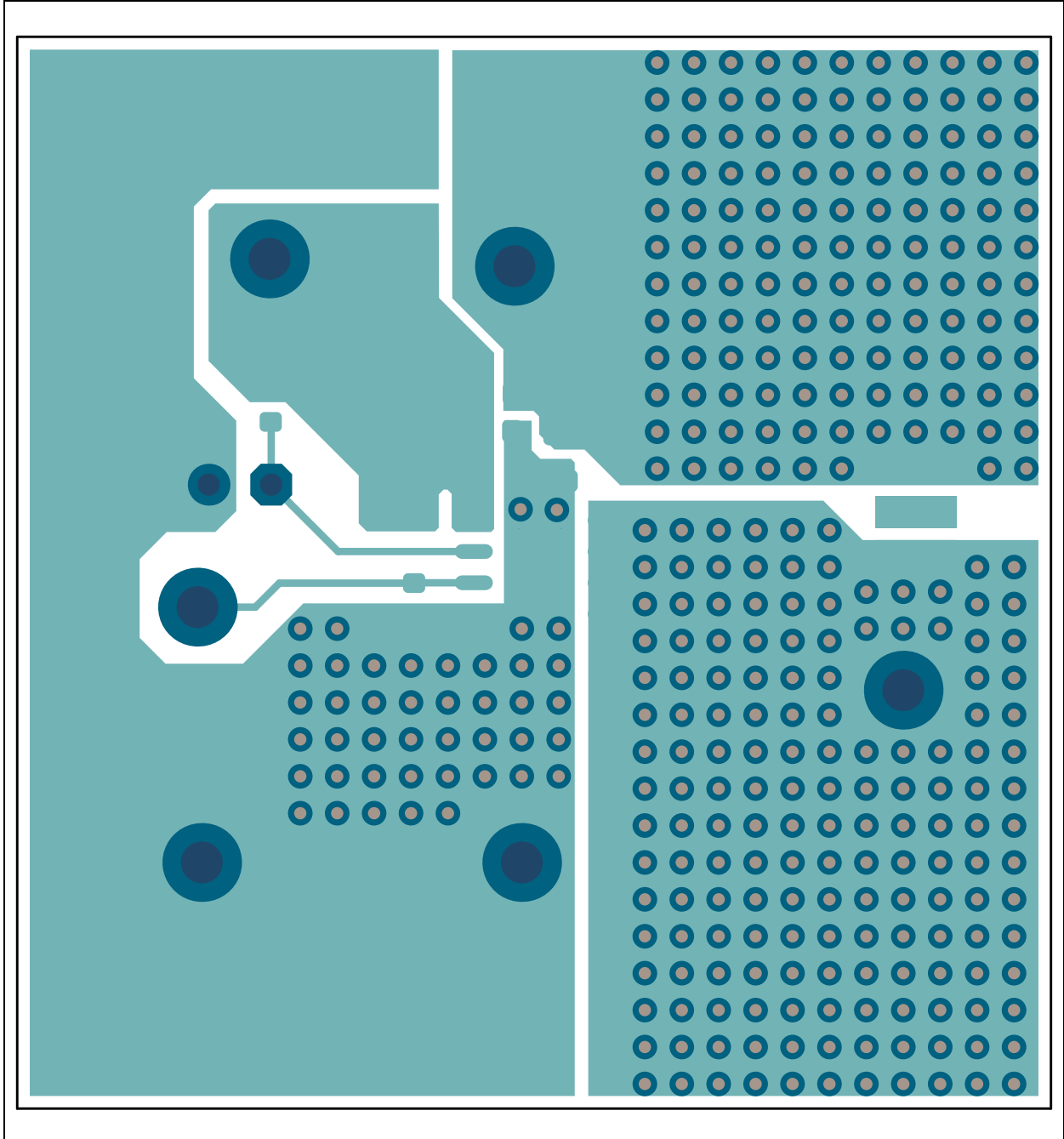

MIC4802 Evaluation Board User's Guide

A.6 BOARD – BOTTOM COPPER LAYER

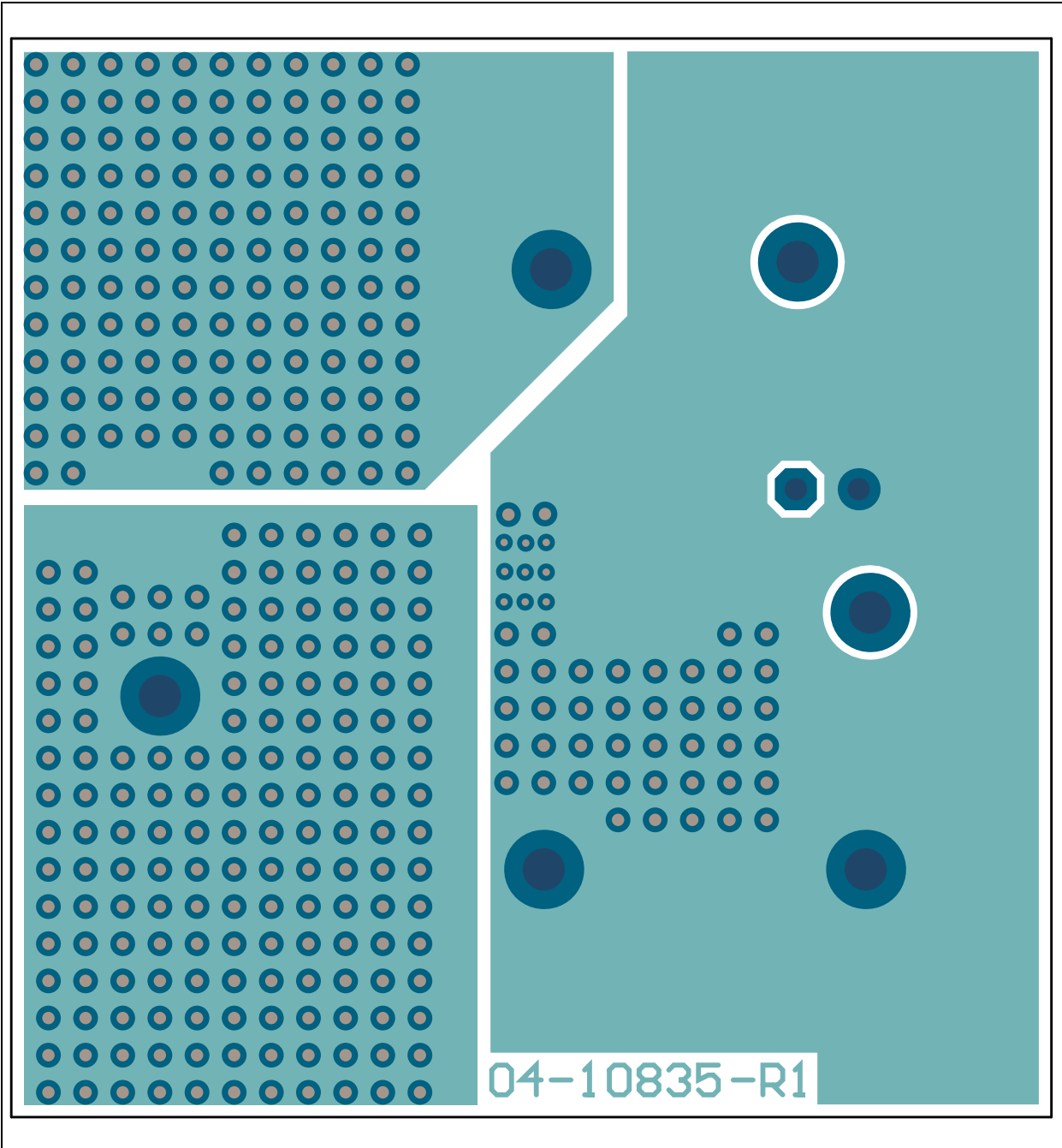

A.7 BOARD – BOTTOM COPPER AND SILK LAYER

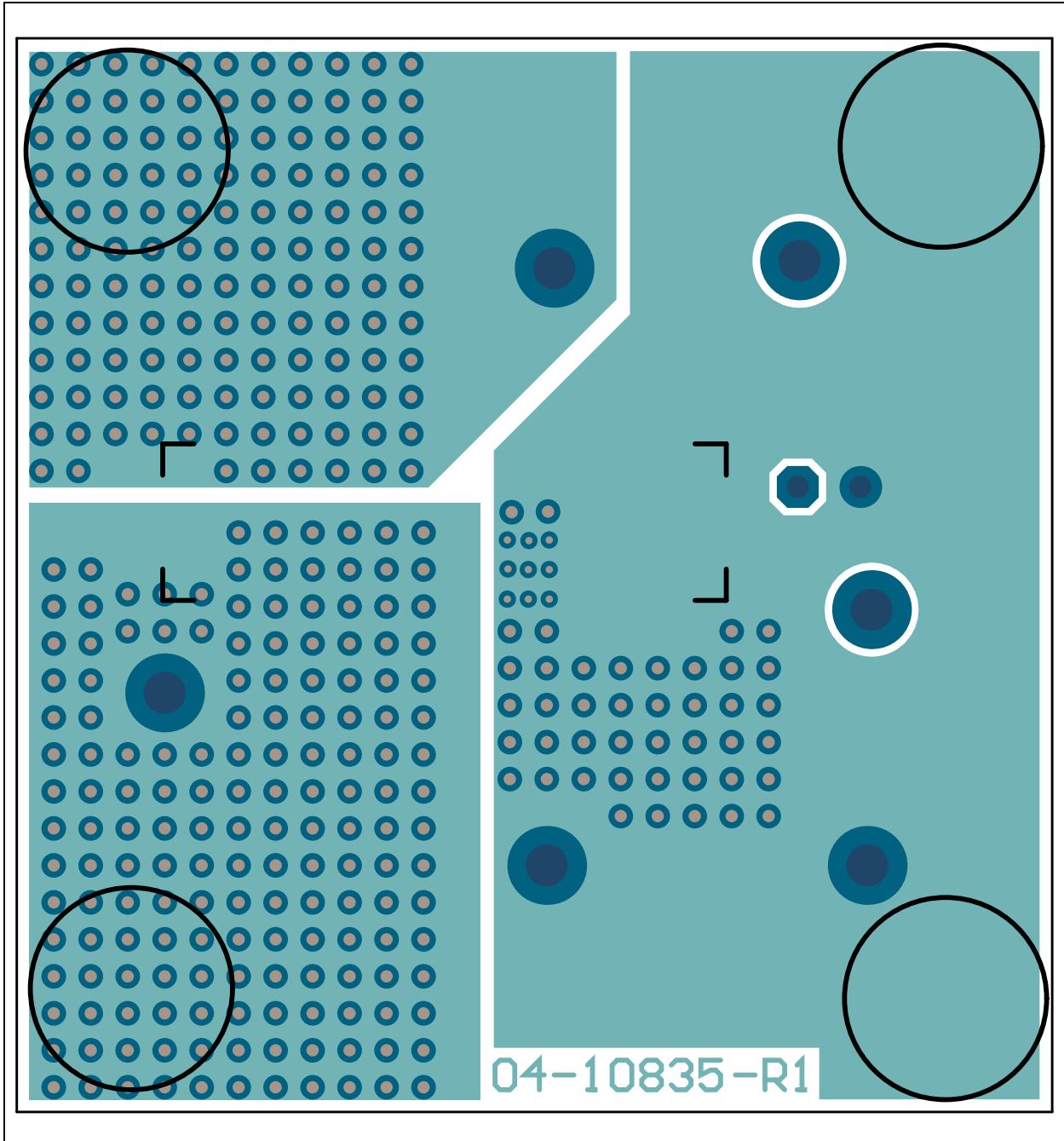

MIC4802 Evaluation Board User's Guide

A.8 BOARD – BOTTOM SILK LAYER

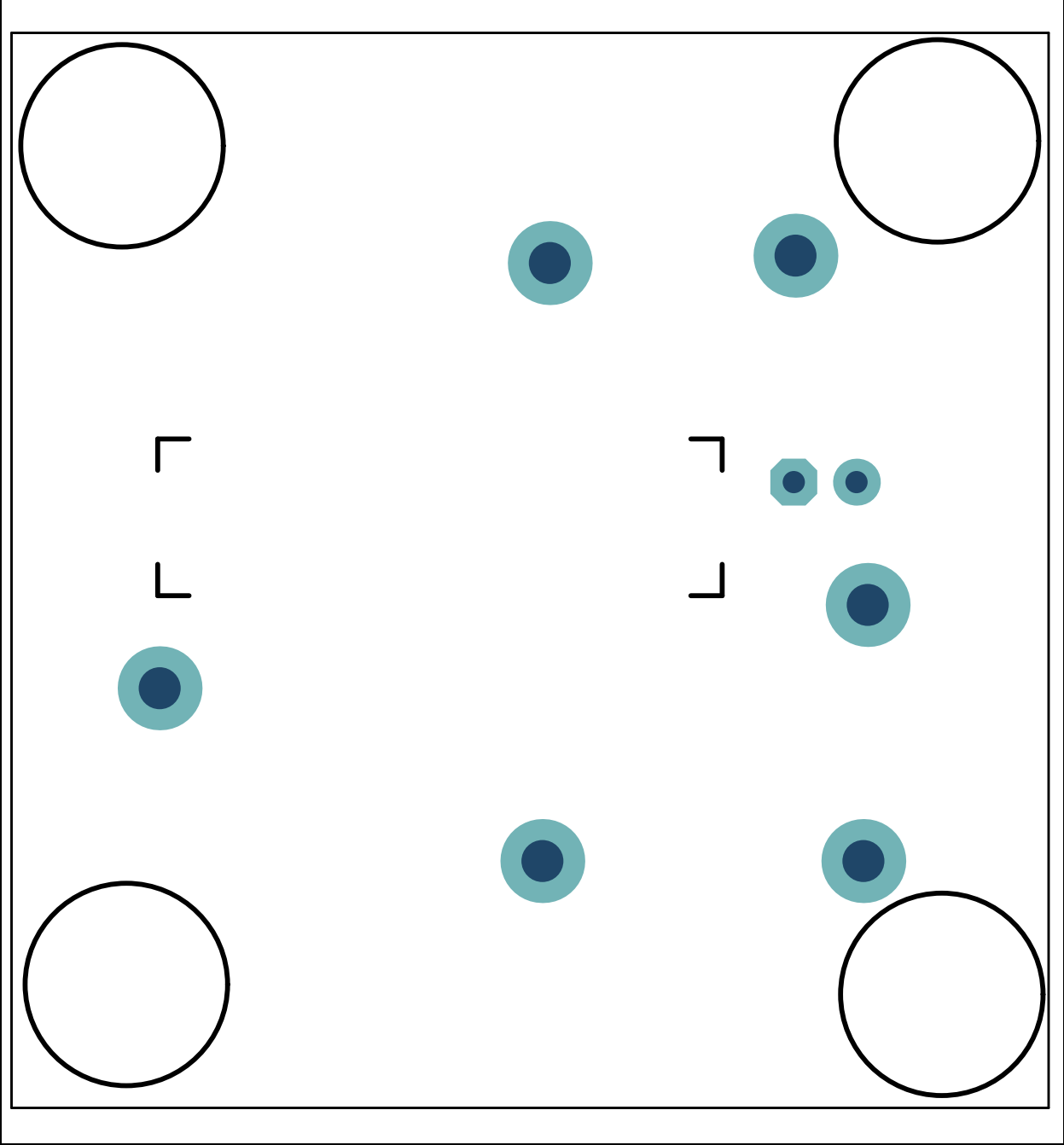

Appendix B. Bill of Materials (BOM)

TABLE B-1: BILL OF MATERIALS (BOM)

Qty.	Reference	Description	Manufacturer	Part Number
2	C1, C2	CAP CER 2.2 μ F 16V 10% X7R SMD 0805	Murata Electronics [®]	GRM21BR71C225KA12L
6	J1, J2, J3, J4, J5, J6	CON TP PIN Tin TH	Harwin Plc.	H2121-01
1	JP1	CON HDR-2.54 Male 1x2 Tin 6.10MH TH VERT	Molex Inc. [®]	0022284020
1	LED1	DIO LED WHITE 3V 350 mA 7000K SMD L3.5W3.5H2.15	Seoul Semiconductor Co., Ltd.	SZ5-M2-W0-00-W3W5-B4C-G
1	PCB	MIC4802 Evaluation Board – Printed Circuit Board	Microchip Technology Inc.	04-10835-R2
1	R1	RES TKF 0R 1/10W SMD 0603	Panasonic [®] – ECG	ERJ-3GSY0R00V
1	R2	RES TKF 100k 1% 1/10W SMD 0603	Panasonic – ECG	ERJ-3EKF1003V
1	R3	RES TKF 10k 1% 1/10W SMD 0603	Panasonic – ECG	ERJ-3EKF1002V
1	R4	RES TKF 8.2k 1% 1/10W SMD 0603	Panasonic – ECG	ERJ-3EKF8201V
1	U1	MCHP ANALOG LED DRIVER 800 mA PWM MIC4802YME SOIC-8	Microchip Technology Inc.	MIC4802YME

Note: The components listed in this Bill of Materials are representative of the PCB assembly. The released BOM used in manufacturing uses all RoHS-compliant components.

TABLE B-2: BILL OF MATERIAL (BOM) – MECHANICAL PARTS

Qty.	Reference	Description	Manufacturer	Part Number
1	LABEL1	LABEL, ASSY W/REV LEVEL (SMALL MODULES) PER MTS-0002	—	—
4	PAD1, PAD2, PAD3, PAD4	MECH HW RUBBER PAD CYLINDRICAL D7.9 H5.3 BLACK	3M	SJ61A11

Note: The components listed in this Bill of Materials are representative of the PCB assembly. The released BOM used in manufacturing uses all RoHS-compliant components.

MIC4802 Evaluation Board User's Guide

NOTES:



MICROCHIP

Worldwide Sales and Service

AMERICAS

Corporate Office
2355 West Chandler Blvd.
Chandler, AZ 85224-6199
Tel: 480-792-7200
Fax: 480-792-7277
Technical Support:
<http://www.microchip.com/support>
Web Address:
www.microchip.com

Atlanta

Duluth, GA
Tel: 678-957-9614
Fax: 678-957-1455

Austin, TX

Tel: 512-257-3370

Boston

Westborough, MA
Tel: 774-760-0087
Fax: 774-760-0088

Chicago

Itasca, IL
Tel: 630-285-0071
Fax: 630-285-0075

Dallas

Addison, TX
Tel: 972-818-7423
Fax: 972-818-2924

Detroit

Novi, MI
Tel: 248-848-4000

Houston, TX

Tel: 281-894-5983

Indianapolis

Noblesville, IN
Tel: 317-773-8323
Fax: 317-773-5453
Tel: 317-536-2380

Los Angeles

Mission Viejo, CA
Tel: 949-462-9523
Fax: 949-462-9608
Tel: 951-273-7800

Raleigh, NC

Tel: 919-844-7510

New York, NY

Tel: 631-435-6000

San Jose, CA

Tel: 408-735-9110
Tel: 408-436-4270

Canada - Toronto

Tel: 905-695-1980
Fax: 905-695-2078

ASIA/PACIFIC

Australia - Sydney
Tel: 61-2-9868-6733

China - Beijing
Tel: 86-10-8569-7000

China - Chengdu
Tel: 86-28-8665-5511

China - Chongqing
Tel: 86-23-8980-9588

China - Dongguan
Tel: 86-769-8702-9880

China - Guangzhou
Tel: 86-20-8755-8029

China - Hangzhou
Tel: 86-571-8792-8115

China - Hong Kong SAR
Tel: 852-2943-5100

China - Nanjing
Tel: 86-25-8473-2460

China - Qingdao
Tel: 86-532-8502-7355

China - Shanghai
Tel: 86-21-3326-8000

China - Shenyang
Tel: 86-24-2334-2829

China - Shenzhen
Tel: 86-755-8864-2200

China - Suzhou
Tel: 86-186-6233-1526

China - Wuhan
Tel: 86-27-5980-5300

China - Xian
Tel: 86-29-8833-7252

China - Xiamen
Tel: 86-592-2388138

China - Zhuhai
Tel: 86-756-3210040

ASIA/PACIFIC

India - Bangalore
Tel: 91-80-3090-4444

India - New Delhi
Tel: 91-11-4160-8631

India - Pune
Tel: 91-20-4121-0141

Japan - Osaka
Tel: 81-6-6152-7160

Japan - Tokyo
Tel: 81-3-6880-3770

Korea - Daegu
Tel: 82-53-744-4301

Korea - Seoul
Tel: 82-2-554-7200

Malaysia - Kuala Lumpur
Tel: 60-3-7651-7906

Malaysia - Penang
Tel: 60-4-227-8870

Philippines - Manila
Tel: 63-2-634-9065

Singapore
Tel: 65-6334-8870

Taiwan - Hsin Chu
Tel: 886-3-577-8366

Taiwan - Kaohsiung
Tel: 886-7-213-7830

Taiwan - Taipei
Tel: 886-2-2508-8600

Thailand - Bangkok
Tel: 66-2-694-1351

Vietnam - Ho Chi Minh
Tel: 84-28-5448-2100

EUROPE

Austria - Wels
Tel: 43-7242-2244-39
Fax: 43-7242-2244-393

Denmark - Copenhagen
Tel: 45-4450-2828
Fax: 45-4485-2829

Finland - Espoo
Tel: 358-9-4520-820

France - Paris
Tel: 33-1-69-53-63-20
Fax: 33-1-69-30-90-79

Germany - Garching
Tel: 49-8931-9700

Germany - Haan
Tel: 49-2129-3766400

Germany - Heilbronn
Tel: 49-7131-67-3636

Germany - Karlsruhe
Tel: 49-721-625370

Germany - Munich
Tel: 49-89-627-144-0
Fax: 49-89-627-144-44

Germany - Rosenheim
Tel: 49-8031-354-560

Israel - Ra'anana
Tel: 972-9-744-7705

Italy - Milan
Tel: 39-0331-742611
Fax: 39-0331-466781

Italy - Padova
Tel: 39-049-7625286

Netherlands - Drunen
Tel: 31-416-690399
Fax: 31-416-690340

Norway - Trondheim
Tel: 47-7289-7561

Poland - Warsaw
Tel: 48-22-3325737

Romania - Bucharest
Tel: 40-21-407-87-50

Spain - Madrid
Tel: 34-91-708-08-90
Fax: 34-91-708-08-91

Sweden - Gothenberg
Tel: 46-31-704-60-40

Sweden - Stockholm
Tel: 46-8-5090-4654

UK - Wokingham
Tel: 44-118-921-5800
Fax: 44-118-921-5820