

NOTES:

1. MATERIAL AND FINISHES:
 WASHER, SHELL - BRASS, NICKEL PLATING
 RETAINER RING - BRASS, NICKEL PLATING
 GASKET - SILICONE RUBBER, RED
 BODY - BRASS, NICKEL PLATING
 CONTACT - PHOSPHOR BRONZE, GOLD PLATING
 RING - DELRIN, NATURAL
 INSULATOR - PTFE, NATURAL

2. ELECTRICAL:
 A. IMPEDANCE: 50 OHM
 B. FREQUENCY RANGE: 0-11 GHz
 C. VSWR (RETURN LOSS): 1.3 (-17.692 dB) MAX.
 D. INSERTION LOSS: 0.15 dB Max. @ 10 GHz
 E. D.W.V: 1500 VRMS. MIN.

3. MECHANICAL:
 A. DURABILITY: 500 CYCLES MIN.
 B. TEMPERATURE RANGE: -40°C TO +85°C

4. PACKAGING:
 A. QUANTITY: SINGLE PACK
 B. BAG TO BE MARKED: AMPHENOL RF
 242131
 DATE CODE

THIRD ANGLE PROJ.

REVISIONS

REV	DESCRIPTION	DATE	ECO	APPR
A	UPDATE DRAWING FORMAT	27-Mar-05	----	G.R.S
B	33 WAS: 37, Ø17 WAS: Ø16.5	10-Apr-14	49976	SH
C	CHANGED TO ONE PIECE BODY FOR IMPROVING IL	25-Dec-17	06321	SH

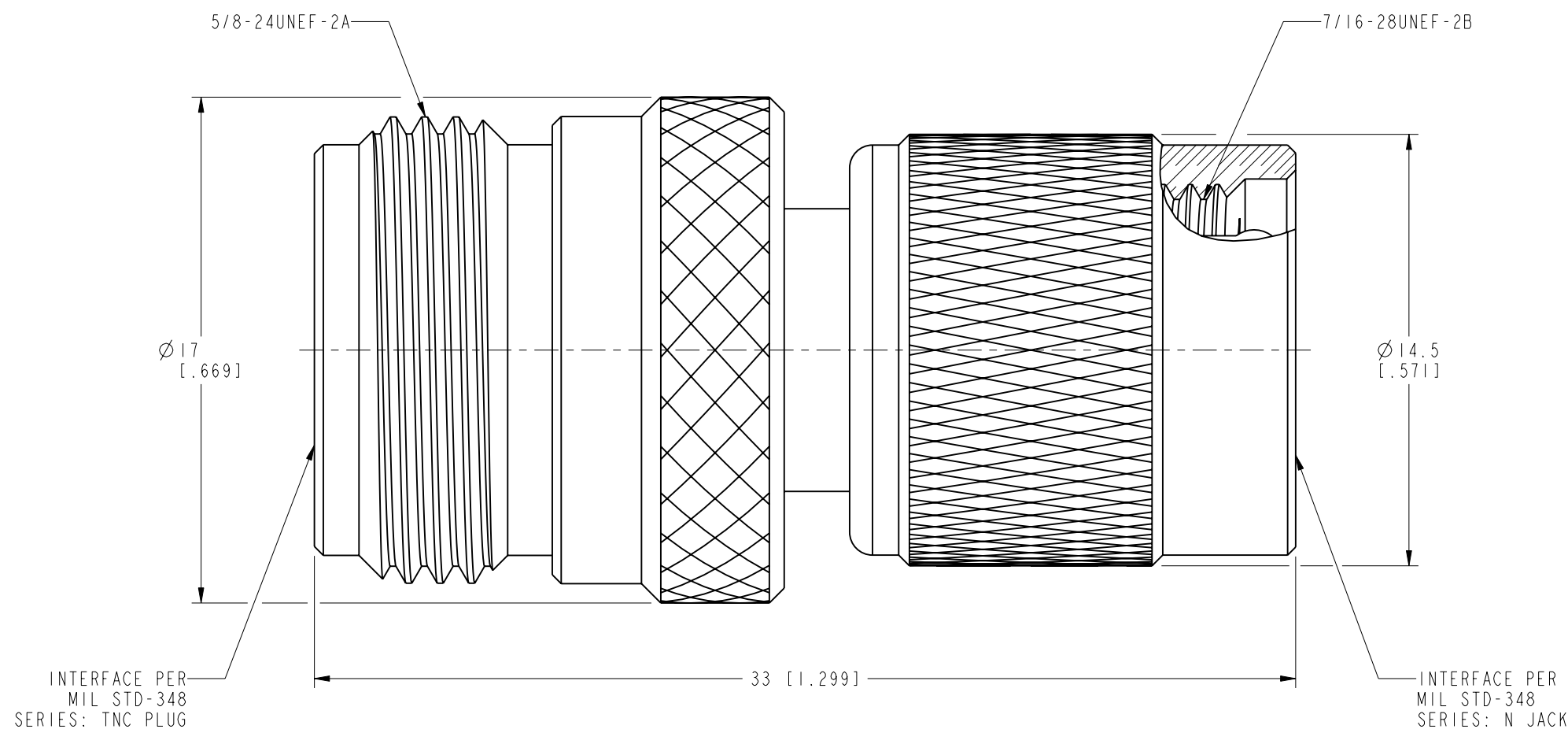
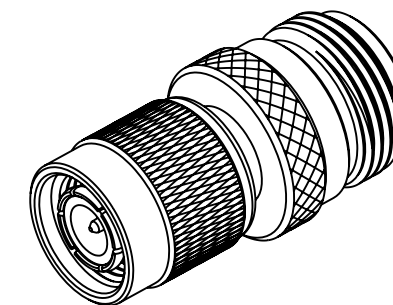

CUSTOMER OUTLINE DRAWING

ALL OTHER SHEETS ARE FOR INTERNAL USE ONLY

UNLESS OTHERWISE SPECIFIED, DIMENSIONS ARE IN METRIC AND TOLERANCES ARE: <0.5mm ±0.05mm 0.5 - 6mm ±0.1mm 6 - 30mm ±0.2mm 30 - 120mm ±0.3mm ANGLES ±1°	MATERIAL	DRAWN M. ZHANG	DATE 25-Dec-17	TITLE TNC MALE TO N FEMALE ADAPTOR		Amphenol RF www.amphenolrf.com	
	REFERENCE AND CONFIGURATION LEVEL: In Work	ENGINEER TONY	DATE 27-May-02				
NOTICE - These drawings, specifications, or other data (1) are, and remain the property of Amphenol corp. (2) must be returned upon request; and (3) are confidential and not to be disclosed to any person other than those to whom they are given by Amphenol Corp. the furnishing of these drawings, specifications, or other data by Amphenol Corp., or to any other person for any purpose is not to be regarded by implication or otherwise in any manner licensing, granting rights to permitting such holder or any other person to manufacture, use or sell any product, process or design, patented or otherwise, that may in any way be related to or disclosed by said drawings, specifications, or other data.	FINISH	APPROVED S. HSIEH	DATE 25-Dec-17	SCALE: 5.0:1.0	SHEET 3 OF 3	ITEM NO. 03F-02M2-NA-5-F	PART NO. 242131
			CAD FILE		DWG SIZE B	REV C	