



4300 MHz Ceramic Band Pass Filter

Part Number: AE4300CB1785



ANATECH ELECTRONICS INC
RF & Microwave Filters & Products

Electrical Specifications

Center Frequency(FO): 4300 MHz
Bandwidth(BW): 200 MHz
Passband: 4200-4400 MHz
Insertion Loss (FO): 2.5 dB Max.
VSWR: 1.7:1 Max.
Ripple in BW: 1.0 dB Max.
Rejection1: 30dB Min @ 4100 MHz
Rejection2: 30dB Min @ 4500 MHz
Impedance: 50 Ohms
Input Power: 1 W

Mechanical

Connector Type: SMT
Dimensions: 34.0 x 14.0 x 5.0 mm.

Environmental

Operating Temperature: -40°C to +80°C
Storage Temperature: -45°C to +85°C
Shock: 10 G. 11ms
Vibration: 10 G. 5 to 200Hz

This product is RoHS compliant.

Outline Drawing:

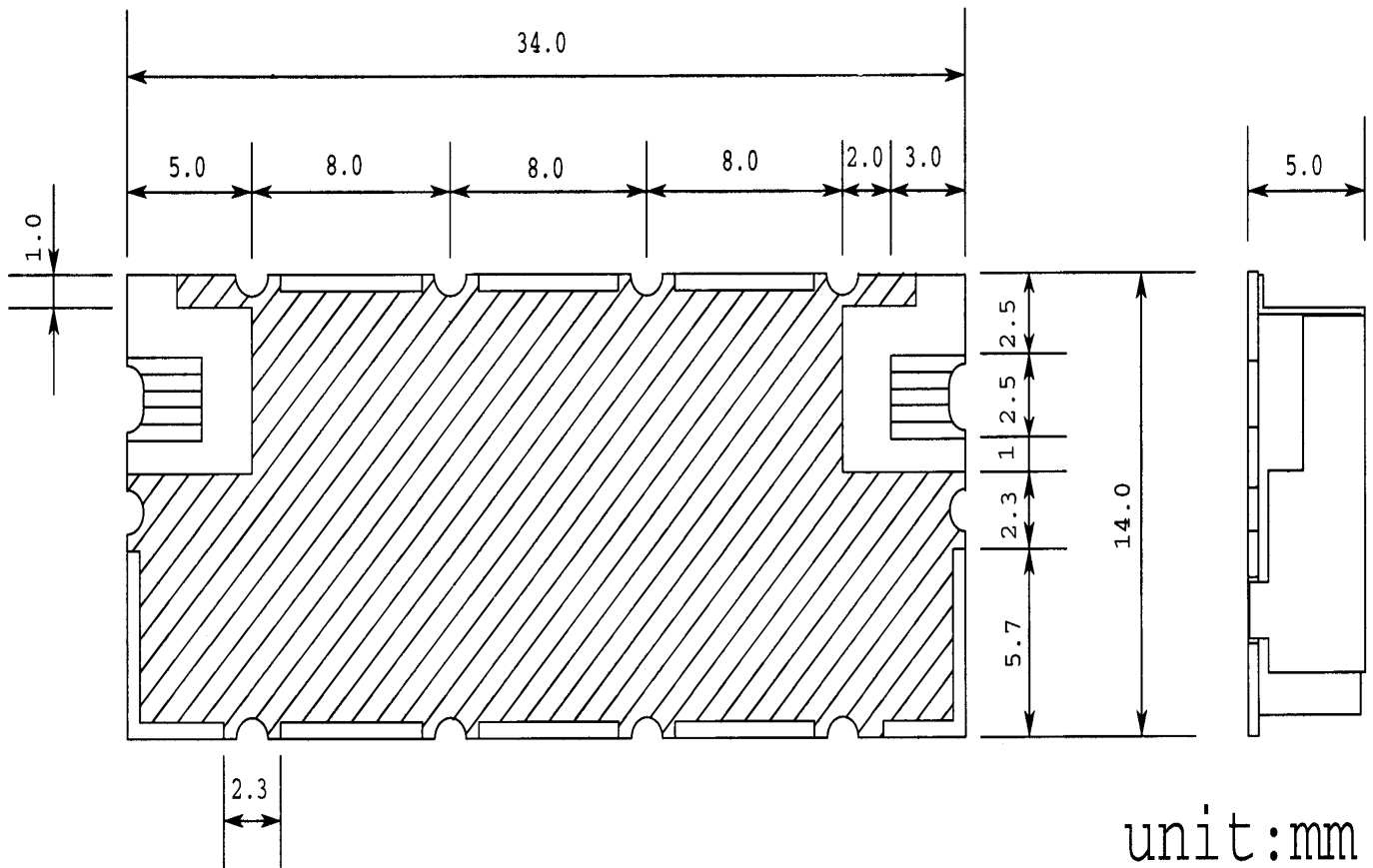

Tolerance: +/-0.01 inches [+/- 0.3mm]

Angles: +/- 1 Deg.

*Tolerance as shown unless otherwise specified in the datasheet electrical specification tables above.

*When max dimensions are called out the above tolerances do not apply as long as it is under the max call out.