

LOC	DIST	REVISIONS					
GP	00	P	LYR	DESCRIPTION	DATE	DWN	APVD
		A		REVISED PER ECO-13-006286	22APR2013	KH	MH

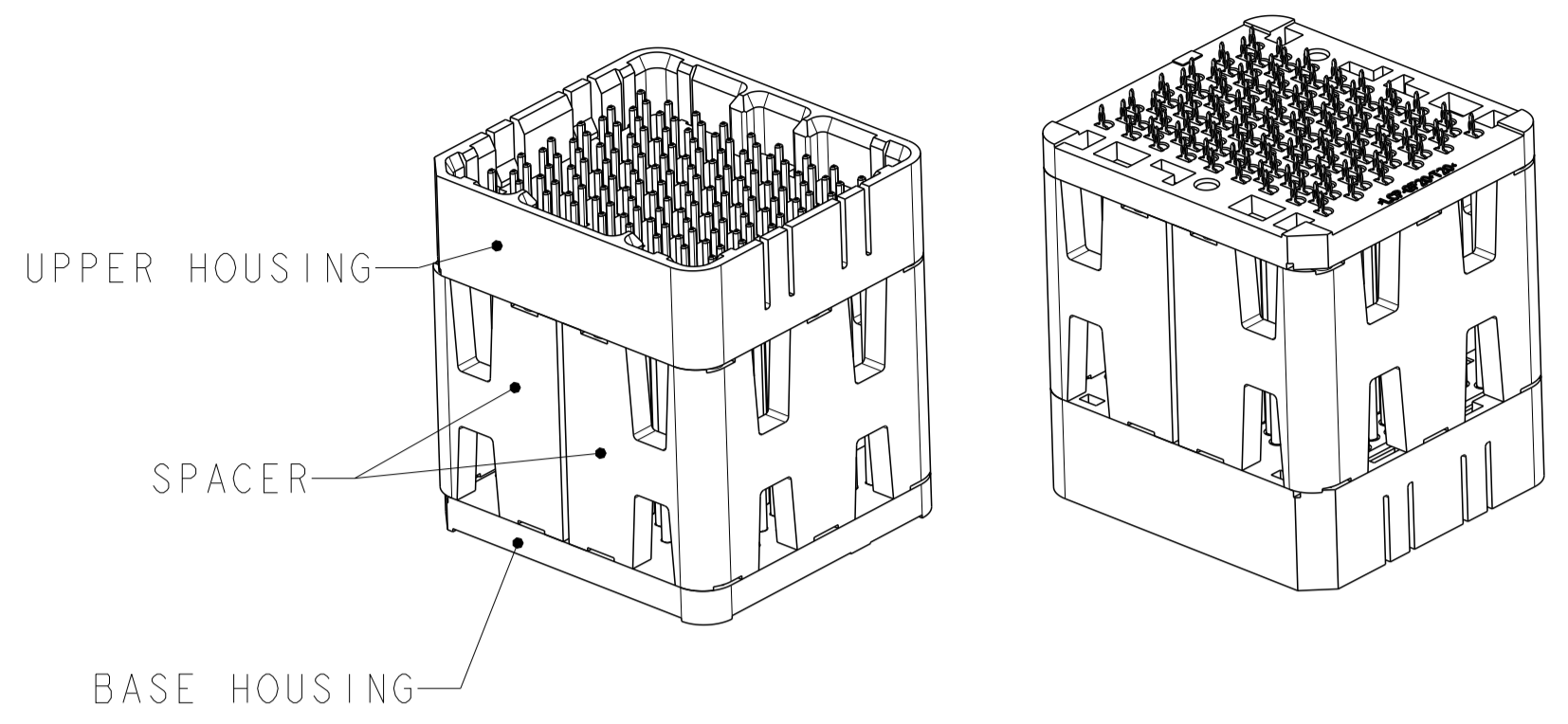

ISOMETRIC VIEWS
 TYPICAL CONFIGURATION FOR 14mm THRU 42mm
 28mm SHOWN
 SCALE 2:1

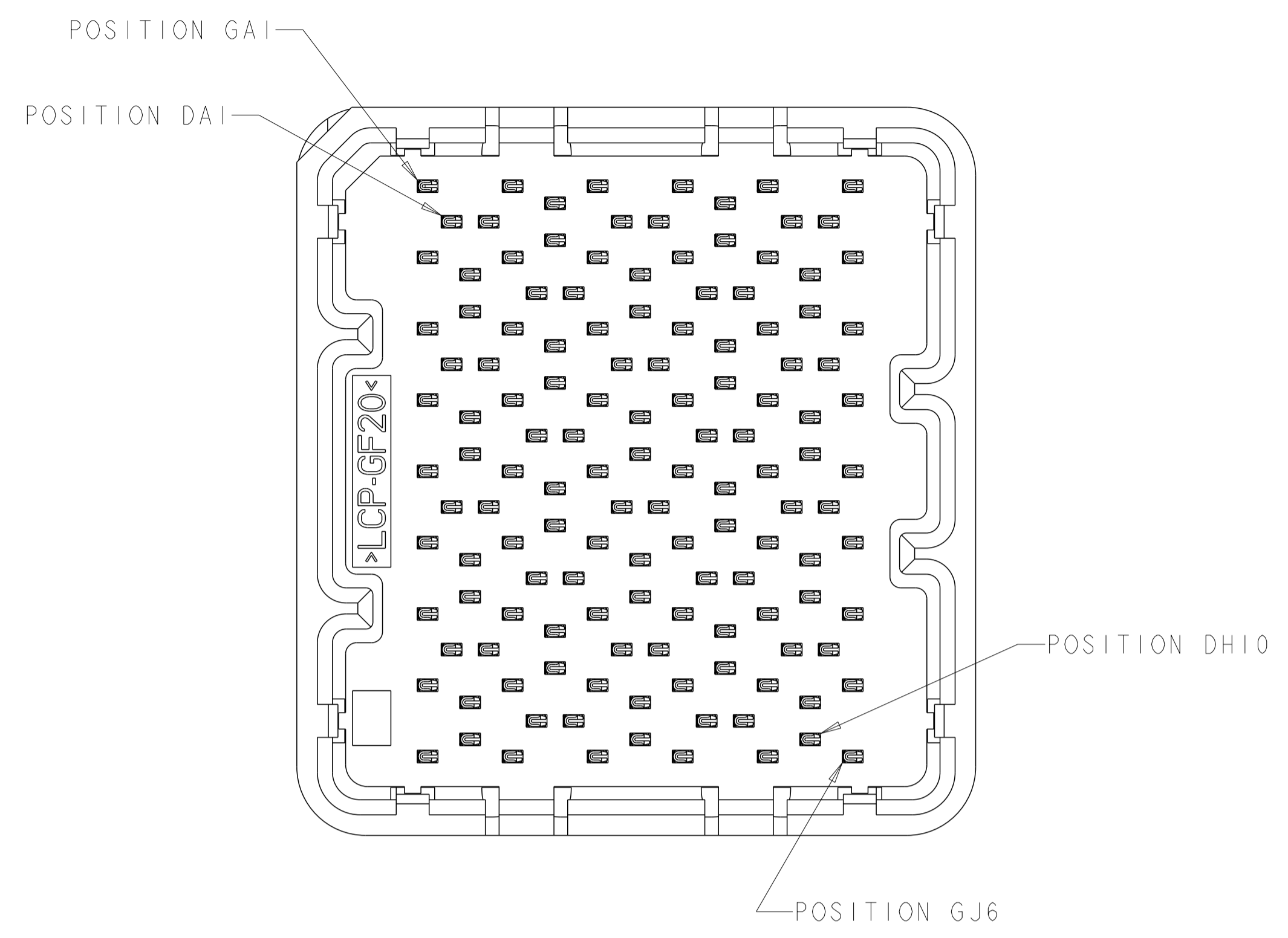
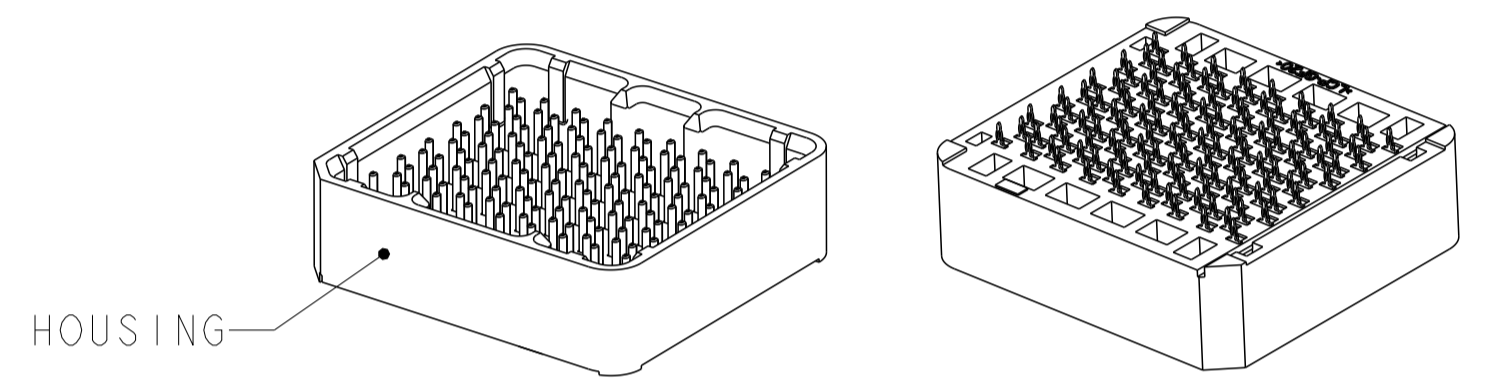

ISOMETRIC VIEWS
 TYPICAL CONFIGURATION FOR 8mm THRU 13mm
 8mm SHOWN
 SCALE 2:1

- 1 MATERIAL:
 BASE HOUSING, UPPER HOUSING, ORGANIZER,
 AND SPACER: THERMOPLASTIC, FLAMMABILITY
 RATING UL94-V0
 CONTACT: COPPER ALLOY
- 2. CONFORMS TO THE REQUIREMENTS OF TE PRODUCT
 SPECIFICATION, 108-2375; BASED ON TELCORDIA
 GR-1217-CORE FOR SYSTEM QUALITY LEVEL III,
 APPLICATIONS IN CONTROLLED ENVIRONMENTS
 (CENTRAL OFFICE).
 SEE TE PRODUCT SPECIFICATION 108-2375 FOR
 TEST SEQUENCES.
- 3 ROWS GA THRU GJ (SHOWN DARKENED) ARE TYPICALLY
 USED AS GROUNDS.
- 4 SPECIFIED POSITIONAL TOLERANCE DEFINES HOLE TO
 HOLE LOCATION WITHIN HOLE PATTERN. POSITIONAL
 TOLERANCE OF HOLE PATTERN TO FIDUCIAL MARKS
 OR PCB DATUMS SHALL BE DEFINED BY CUSTOMER.
- 5 AREA RESERVED FOR TE CONNECTIVITY LOGO.
- 6 AREA RESERVED FOR PART NUMBER (X-XXXXXX-X)
 AND DATE CODE (YYWW).
- 7 USE CENTERLINES INDICATED ON PCB HOLE PATTERN
 TO ESTABLISH ALIGNMENT BETWEEN HEADER AND
 RECEPTACLE BOARDS.
- 8 PLATED THROUGH HOLE REQUIREMENTS:
 HOLE SIZE PRIOR TO PLATING = $\varnothing 0.420 \pm 0.013$
 COPPER PLATING THICKNESS = 0.038 ± 0.013
 CALCULATED FINISHED HOLE SIZE = $\varnothing 0.344 \pm 0.039$
 THESE DIMENSIONS APPLY TO THE TOP 1.25mm OF
 THE PCB THICKNESS FROM THE CONNECTOR MOUNTING
 SIDE.
- 9 CONTACT SALES FOR AVAILABILITY OF THIS STACK
 HEIGHT.

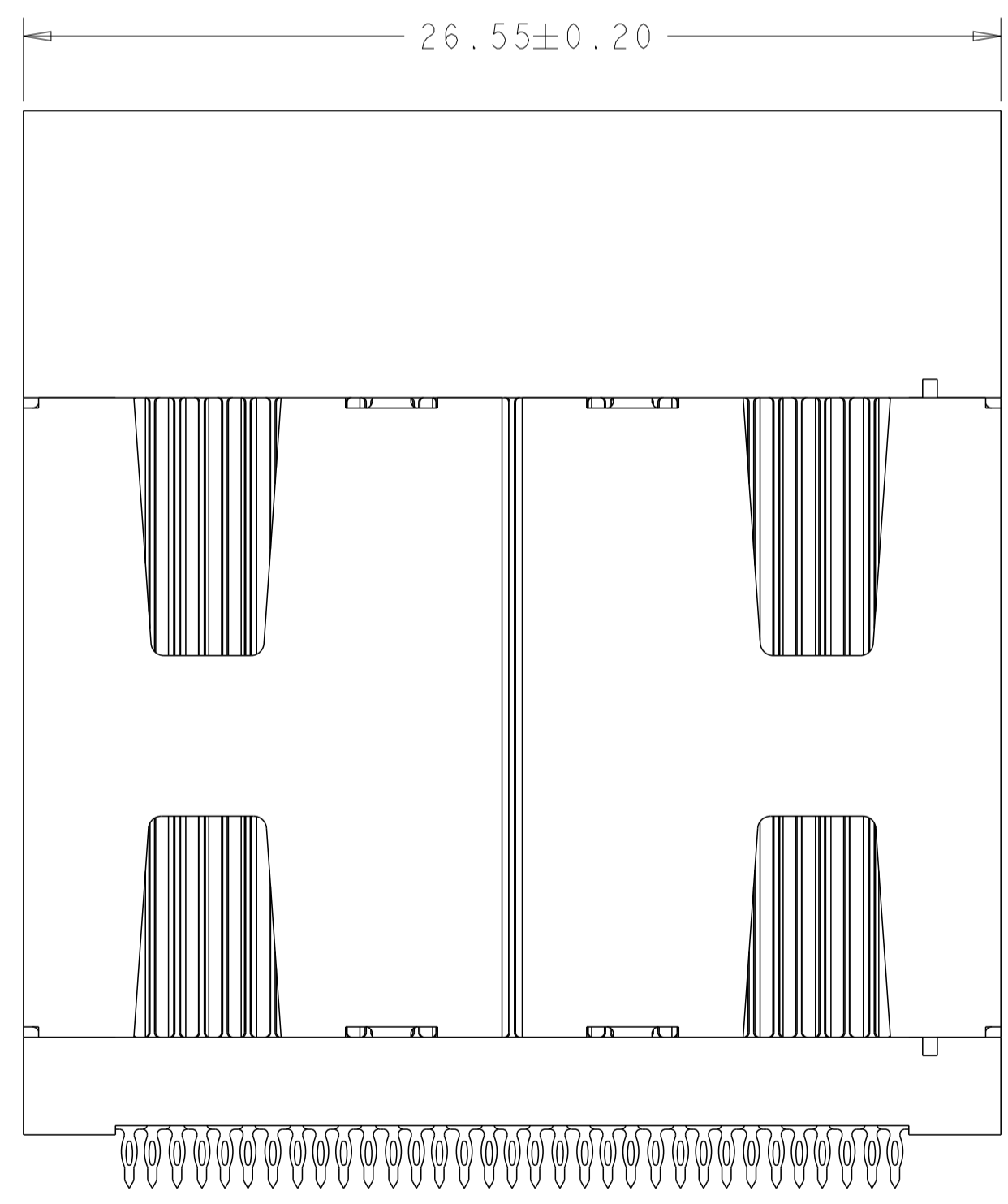
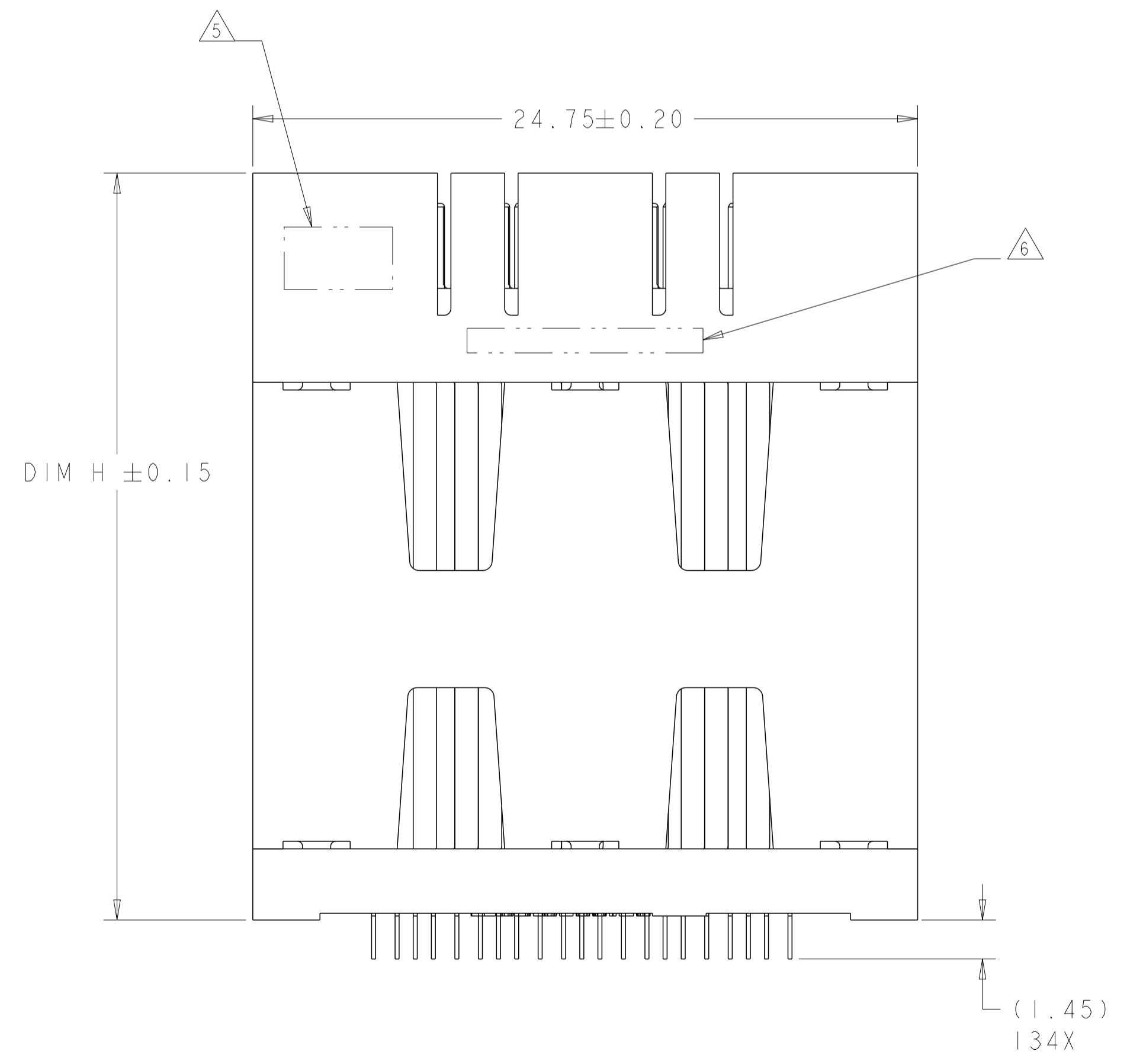

SIZE 1 HOUSING *
40 DIFFERENTIAL PAIRS
134 TOTAL SIGNAL CONTACTS

* SIZE 2 AND SIZE 3 ARE ALSO AVAILABLE

THIS DRAWING IS A CONTROLLED DOCUMENT.		DWN D. RINGLER 14FEB2009	TE Connectivity
DIMENSIONS: mm		CHK D. TROUT 14FEB2009	
TOLERANCES UNLESS OTHERWISE SPECIFIED:		APVD J. FEEDER 14FEB2009	NAME HEADER ASSEMBLY 40/134 SIGNAL STRADA MESA MEZZANINE CONNECTOR
0 PLC	±	PRODUCT SPEC	SIZE
2 PLC	±0.13	APPLICATION SPEC	CAGE CODE
3 PLC	±0.013	114-13249	DRAWING NO
4 PLC	±	WEIGHT	RESTRICTED TO
ANGLES	±1		A100779C=2110320
FINISH		Customer Drawing	SCALE 6:1 SHEET 1 OF 4 REV A

THIS DRAWING IS UNPUBLISHED. RELEASED FOR PUBLICATION 20
 © COPYRIGHT 20 BY - ALL RIGHTS RESERVED.

LOC	DIST	REVISIONS			
P	LYN	DESCRIPTION	DATE	OWN	APVD
-	-	SEE SHEET 1	-	-	-

	41.8	42mm	MATTE Sn	9-2110320-2
	40.8	41mm	MATTE Sn	9-2110320-1
	39.8	40mm	MATTE Sn	9-2110320-0
	38.8	39mm	MATTE Sn	8-2110320-9
	37.8	38mm	MATTE Sn	8-2110320-8
	36.8	37mm	MATTE Sn	8-2110320-7
	35.8	36mm	MATTE Sn	8-2110320-6
	34.8	35mm	MATTE Sn	8-2110320-5
	33.8	34mm	MATTE Sn	8-2110320-4
	32.8	33mm	MATTE Sn	8-2110320-3
	31.8	32mm	MATTE Sn	8-2110320-2
	30.8	31mm	MATTE Sn	8-2110320-1
	29.8	30mm	MATTE Sn	8-2110320-0
	28.8	29mm	MATTE Sn	7-2110320-9
	27.8	28mm	MATTE Sn	7-2110320-8
	26.8	27mm	MATTE Sn	7-2110320-7
	25.8	26mm	MATTE Sn	7-2110320-6
	24.8	25mm	MATTE Sn	7-2110320-5
	23.8	24mm	MATTE Sn	7-2110320-4
	22.8	23mm	MATTE Sn	7-2110320-3
	21.8	22mm	MATTE Sn	7-2110320-2
	20.8	21mm	MATTE Sn	7-2110320-1
	19.8	20mm	MATTE Sn	7-2110320-0
	18.8	19mm	MATTE Sn	6-2110320-9
	17.8	18mm	MATTE Sn	6-2110320-8
	16.8	17mm	MATTE Sn	6-2110320-7
	15.8	16mm	MATTE Sn	6-2110320-6
	14.8	15mm	MATTE Sn	6-2110320-5
	13.8	14mm	MATTE Sn	6-2110320-4
	12.8	13mm	MATTE Sn	6-2110320-3
	11.8	12mm	MATTE Sn	6-2110320-2
	10.8	11mm	MATTE Sn	6-2110320-1
	9.8	10mm	MATTE Sn	6-2110320-0
YES	8.8	9mm	MATTE Sn	5-2110320-9
YES	7.8	8mm	MATTE Sn	5-2110320-8
TOOLED	DIM H	STACK HEIGHT	CONTACT TAIL PLATING	PART NUMBER

	41.8	42mm	Sn/Pb	4-2110320-2
	40.8	41mm	Sn/Pb	4-2110320-1
	39.8	40mm	Sn/Pb	4-2110320-0
	38.8	39mm	Sn/Pb	3-2110320-9
	37.8	38mm	Sn/Pb	3-2110320-8
	36.8	37mm	Sn/Pb	3-2110320-7
	35.8	36mm	Sn/Pb	3-2110320-6
	34.8	35mm	Sn/Pb	3-2110320-5
	33.8	34mm	Sn/Pb	3-2110320-4
	32.8	33mm	Sn/Pb	3-2110320-3
	31.8	32mm	Sn/Pb	3-2110320-2
	30.8	31mm	Sn/Pb	3-2110320-1
	29.8	30mm	Sn/Pb	3-2110320-0
	28.8	29mm	Sn/Pb	2-2110320-9
	27.8	28mm	Sn/Pb	2-2110320-8
	26.8	27mm	Sn/Pb	2-2110320-7
	25.8	26mm	Sn/Pb	2-2110320-6
	24.8	25mm	Sn/Pb	2-2110320-5
	23.8	24mm	Sn/Pb	2-2110320-4
	22.8	23mm	Sn/Pb	2-2110320-3
	21.8	22mm	Sn/Pb	2-2110320-2
	20.8	21mm	Sn/Pb	2-2110320-1
	19.8	20mm	Sn/Pb	2-2110320-0
	18.8	19mm	Sn/Pb	1-2110320-9
	17.8	18mm	Sn/Pb	1-2110320-8
	16.8	17mm	Sn/Pb	1-2110320-7
	15.8	16mm	Sn/Pb	1-2110320-6
	14.8	15mm	Sn/Pb	1-2110320-5
	13.8	14mm	Sn/Pb	1-2110320-4
	12.8	13mm	Sn/Pb	1-2110320-3
	11.8	12mm	Sn/Pb	1-2110320-2
	10.8	11mm	Sn/Pb	1-2110320-1
	9.8	10mm	Sn/Pb	1-2110320-0
YES	8.8	9mm	Sn/Pb	2110320-9
YES	7.8	8mm	Sn/Pb	2110320-8
TOOLED	DIM H	STACK HEIGHT	CONTACT TAIL PLATING	PART NUMBER

THIS DRAWING IS A CONTROLLED DOCUMENT. **STE** TE Connectivity

CHK: D. RINGLER 14FEB2009
 D. TROUT 14FEB2009

APVD: J. EEDER 14FEB2009

NAME: HEADER ASSEMBLY
 40/134 SIGNAL
 STRADA MESA MEZZANINE CONNECTOR

PRODUCT SPEC: 108-2375
 APPLICATION SPEC: 114-13249

SIZE: A1 CAGE CODE: 00779 DRAWING NO: 2110320

RESTRICTED TO: -

Customer Drawing SCALE: 6:1 SHEET 2 OF 4 REV A

LOC	DIST	REVISIONS					
GP	00	P	LYR	DESCRIPTION	DATE	DWN	APVD
		-		SEE SHEET 1			

AI CORNER INDICATORS.

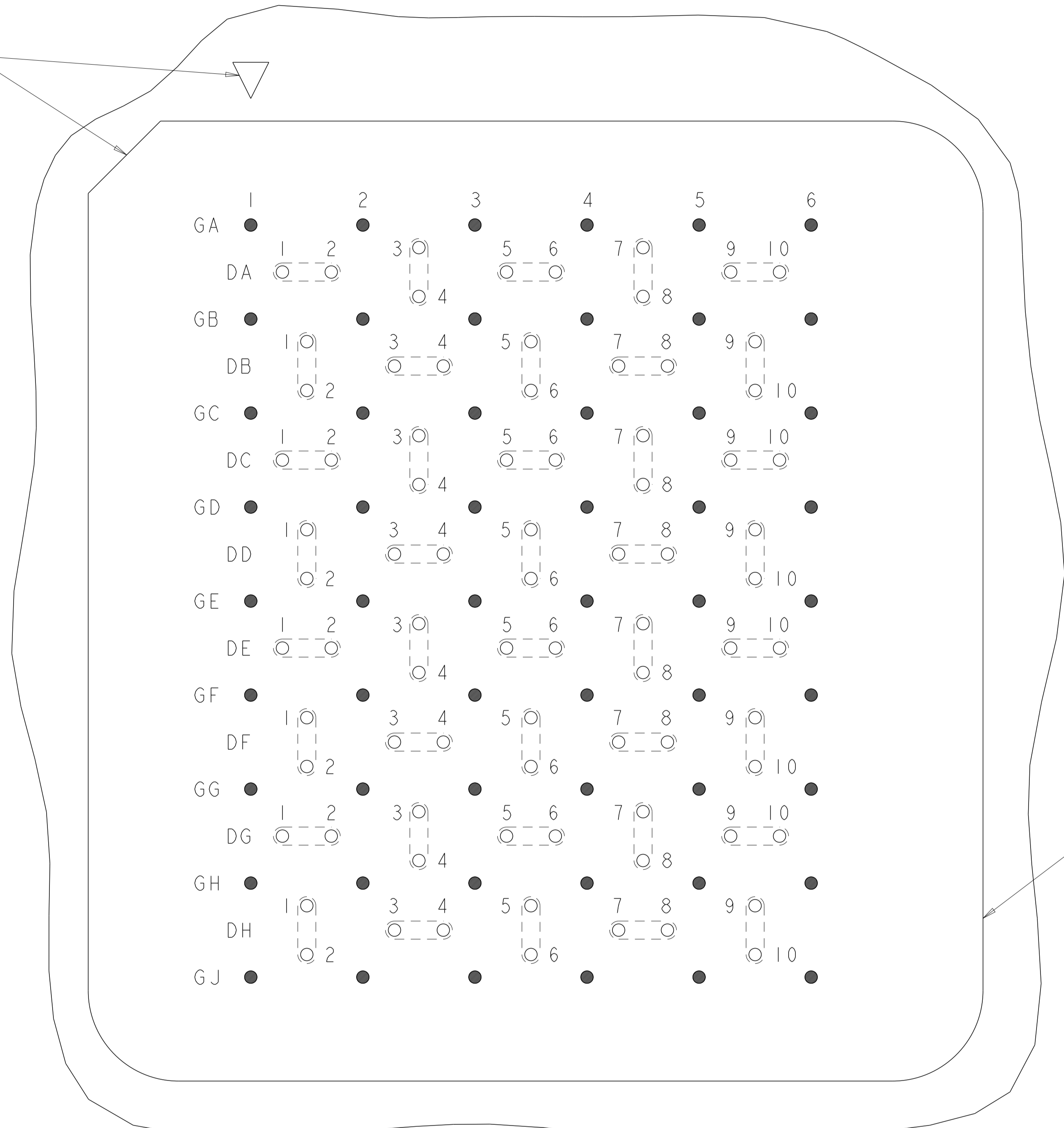

MATED CONNECTOR OUTLINE
 SEE SHEET 4 FOR LOCATION TO HOLES

PCB LAYOUT AND PIN IDENTIFICATION 
 SHOWN FROM CONNECTOR SIDE
 SCALE 12:1

THIS DRAWING IS A CONTROLLED DOCUMENT.		DWN D. RINGLER 14FEB2009	 TE Connectivity
DIMENSIONS: mm		CHK D. TROUT 14FEB2009	
TOLERANCES UNLESS OTHERWISE SPECIFIED: 0 PLC ± 2 PLC ±0.13 3 PLC ±0.013 4 PLC ± ANGLES ±1		APVD J. FEEDER 14FEB2009	NAME HEADER ASSEMBLY 40/134 SIGNAL STRADA MESA MEZZANINE CONNECTOR
MATERIAL		114-13249	RESTRICTED TO
FINISH		WEIGHT	SIZE CAGE CODE DRAWING NO A100779C=2110320
		Customer Drawing	SCALE 6:1 SHEET 3 OF 4 REV A

