

CKT. SIZE	DIM. 'A'	DIM. 'B'	DIM. 'C'	DIM. 'D'	DIM. 'E'	DIM. 'F'	DIM. 'G'	DIM. 'H'
2	.147 (36.00)	N/A	.984 (25.00)	.984 (25.00)	.528 (13.40)	.398 (10.10)	.343 (8.70)	.213 (5.40)
4	.1583 (40.20)	.165 (4.20)	1.150 (29.20)	1.150 (29.20)	.695 (17.60)	.563 (14.30)	.508 (12.90)	.378 (9.60)
6	1.748 (44.40)	.331 (8.40)	1.315 (33.40)	1.315 (33.40)	1.189 (30.20)	.798 (20.30)	.673 (17.10)	.443 (11.30)
8	1.913 (48.60)	.496 (12.60)	1.480 (37.60)	1.480 (37.60)	1.024 (26.00)	.894 (22.70)	.839 (21.30)	.709 (18.00)
10	2.078 (52.80)	.61 (16.80)	1.645 (41.80)	1.645 (41.80)	1.189 (30.20)	1.059 (26.90)	1.004 (25.50)	.874 (22.20)
12	2.244 (57.00)	.827 (21.00)	1.811 (46.00)	1.811 (46.00)	1.354 (34.40)	1.224 (31.10)	1.169 (29.70)	1.039 (26.40)
14	2.409 (61.20)	.992 (25.20)	1.976 (50.20)	1.976 (50.20)	1.520 (38.60)	1.390 (35.30)	1.335 (33.90)	1.205 (30.60)
16	2.575 (65.40)	1.157 (29.40)	2.142 (54.40)	2.142 (54.40)	1.685 (42.80)	1.555 (39.50)	1.500 (38.10)	1.370 (34.80)
18	2.740 (69.60)	1.323 (33.60)	2.307 (58.60)	2.307 (58.60)	1.850 (47.00)	1.720 (43.70)	1.665 (42.30)	1.535 (39.00)
20	2.906 (73.80)	1.488 (37.80)	2.472 (62.80)	2.472 (62.80)	2.016 (51.20)	1.886 (47.90)	1.831 (46.50)	1.701 (43.20)
22	3.071 (78.00)	1.653 (42.00)	2.638 (67.00)	2.638 (67.00)	2.181 (55.40)	2.051 (52.10)	1.996 (50.70)	1.866 (47.40)
24	3.236 (82.20)	1.819 (46.20)	2.803 (71.20)	2.803 (71.20)	2.346 (59.60)	2.217 (56.30)	2.161 (54.90)	2.031 (51.60)

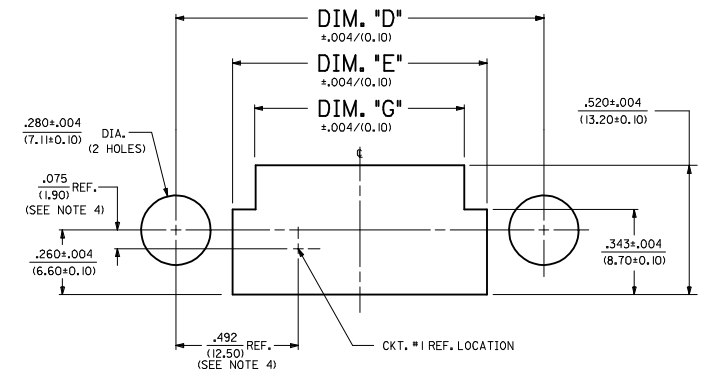
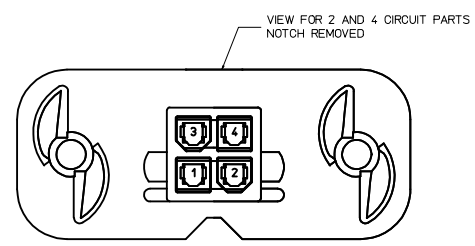
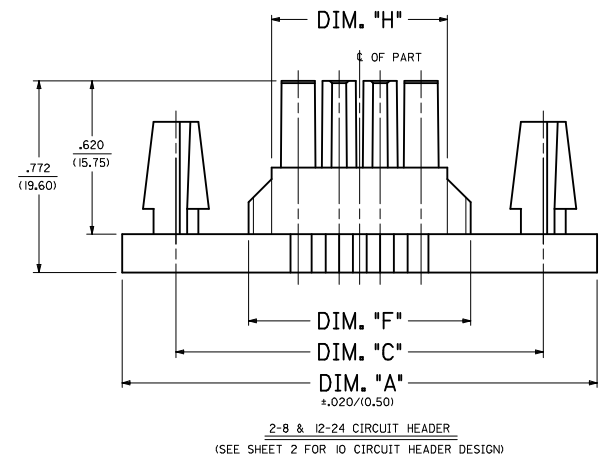
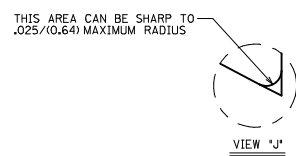

**LEGEND:**  
 42474 - \*\*\* 2  
 BASE NUMBER  
 CIRCUIT SIZE (02-24)  
 MATERIAL (SEE NOTE 1)

- NOTES:**
- MATERIAL:  
 \*1 = NYLON 6/6, 94V-2, COLOR: NATURAL.  
 \*2 = NYLON 6/6, 94V-0, COLOR: NATURAL.  
 \*3 = NYLON 6/6, 94V-2, COLOR: BLACK.  
 \*4 = NYLON 6/6, 94V-0, COLOR: BLACK.
  - FINISH NOT APPLICABLE.
  - PRODUCT SPECIFICATION PS-5556-002.
  - PACKAGING: PK-42474-001
  - PART MATES WITH MINI-FIT B.M.I. PLUG #42475, AND HEADERS 42404, 42440.
  - PART TO BE USED WITH MOLEX FEMALE TERMINAL #5556.
  - THIS CONNECTOR ALLOWS FOR .050/(1.27) MAX. MISALIGNMENT IN ANY DIRECTION.
  - THIS DIMENSION TO BE USED FOR ALIGNMENT OF THE MATING CONNECTOR.
  - CONNECTOR ASSEMBLIES ARE NOT TO BE MATED OR UNMATED WHILE CIRCUITS ARE LIVE.
  - PART TO BE USED WITH .101/(2.57) MAX. THICK PANEL.
  - THIS PART IS INTENDED FOR ONE PANEL INSERTION ONLY. REMOVAL AND RE-INSERTION CAN DAMAGE THE MOUNTING SPIRALS.
  - PANEL SHOULD BE PUNCHED IN THE DIRECTION OF CONNECTOR INSERTION.
  - BOTH SPIRALS SHOULD BE INSERTED INTO THE PANEL AT THE SAME TIME. ROCKING THE PART INTO PLACE MAY CAUSE SPIRAL DAMAGE.
  - THIS PART IS NOT INTENDED TO PROVIDE ANY ALIGNMENT OF CUSTOMER COMPONENTS OR MODULES, SUCH AS POWER SUPPLIES AND CHASSIS.
  - IF THIS PRODUCT IS STORED IN AN ENVIRONMENT WITH A RELATIVE HUMIDITY OF LESS THAN 50% MOISTURE MUST BE ADDED. REFER TO TECHNICAL ADVISORY AS-45499-001 FOR INSTRUCTIONS.
  - A MAXIMUM TOLERANCE OF .050/(1.27) ALLOWS FOR 2 POINTS OF ELECTRICAL CONTACT. A MAXIMUM TOLERANCE OF .020/(1.51) ALLOWS FOR 4 POINTS OF CONTACT.
  - WIRES ARE TO BE DRESSED IN SUCH A MANNER TO ALLOW THE TERMINALS TO FLOAT FREELY IN THE POCKET.
  - PART CONFORMS TO CLASS "B" REQUIREMENTS OF COSMETIC SPECIFICATION PS-45499-002

<b>DIM. 'A' TOLERANCE</b> EC NO. UCP2008-0703 DRAWN: SCHMIDT 2007/10/10 CHECKED BY: CHYKOSOUSEK 2007/10/19 APPROVED: FSWITH 2007/10/22 REV. 01	<b>QUALITY SYMBOLS</b> 0 = 0 1 = 0.15 2 = 0.38 3 = 0.76 4 = 1.52 5 = 3.05 6 = 6.10 7 = 12.20 8 = 24.40 9 = 48.80 10 = 97.60 11 = 195.20 12 = 390.40 13 = 780.80 14 = 1561.60 15 = 3123.20 16 = 6246.40 17 = 12492.80 18 = 24985.60 19 = 49971.20 20 = 99942.40 21 = 199884.80 22 = 399769.60 23 = 799539.20 24 = 1599078.40	<b>GENERAL TOLERANCES (UNLESS SPECIFIED)</b> <table border="1"> <tr> <th></th> <th>mm</th> <th>INCH</th> </tr> <tr> <td>4 PLACES</td> <td>± .15</td> <td>± .005</td> </tr> <tr> <td>3 PLACES</td> <td>± .10</td> <td>± .003</td> </tr> <tr> <td>2 PLACES</td> <td>± .08</td> <td>± .002</td> </tr> <tr> <td>1 PLACE</td> <td>± .05</td> <td>± .001</td> </tr> </table> ANGULAR ±1/2° DRAFT WHERE APPLICABLE MUST REMAIN WITHIN DIMENSIONS		mm	INCH	4 PLACES	± .15	± .005	3 PLACES	± .10	± .003	2 PLACES	± .08	± .002	1 PLACE	± .05	± .001	<b>DIMENSION STYLE</b> IN/MM DRAWN BY: GEP DATE: 1993/05/10 CHECKED BY: R/JF DATE: 1993/05/10 APPROVED BY: R/JF DATE: 1993/05/10 MATERIAL NO. SEE SHEET 2 DOCUMENT NO. SD-42474-***2	<b>SCALE</b> 4:1 <b>DESIGN UNITS</b> METRIC <b>THIRD ANGLE PROJECTION</b>	<b>PANEL MNT RECEPTACLE</b> MINI-FIT B.M.I. SERIES FOR .094 MAX. THICK PANEL <b>MOLEX INCORPORATED</b> SHEET NO. 1 OF 2
		mm	INCH																	
	4 PLACES	± .15	± .005																	
	3 PLACES	± .10	± .003																	
2 PLACES	± .08	± .002																		
1 PLACE	± .05	± .001																		

13	12	11	10	9	8	7	6	5	4	3	2	1	
PART NUMBER	ENG. NUMBER	CKT. SIZE	MATERIAL (SEE NOTE 1.)	PART NUMBER	ENG. NUMBER	CKT. SIZE	MATERIAL (SEE NOTE 1.)	ITEM NUMBER	CKT. SIZE	MATERIAL (SEE NOTE 1.)	ITEM NUMBER	CKT. SIZE	MATERIAL (SEE NOTE 1.)
NOT TOOLED	42474-0212	2	94V-2	NOT TOOLED	42474-0222	2	94V-0	NOT TOOLED	2	94V-2	NOT TOOLED	2	94V-0
15-06-0042	42474-0412	4	94V-2	NOT TOOLED	42474-0422	4	94V-0	NOT TOOLED	4	94V-2	NOT TOOLED	4	94V-0
NOT TOOLED	42474-0612	6	94V-2	NOT TOOLED	42474-0622	6	94V-0	NOT TOOLED	6	94V-2	NOT TOOLED	6	94V-0
NOT TOOLED	42474-0812	8	94V-2	NOT TOOLED	42474-0822	8	94V-0	NOT TOOLED	8	94V-2	NOT TOOLED	8	94V-0
NOT TOOLED	42474-1012	10	94V-2	NOT TOOLED	42474-1022	10	94V-0	NOT TOOLED	10	94V-2	NOT TOOLED	10	94V-0
NOT TOOLED	42474-1212	12	94V-2	NOT TOOLED	42474-1222	12	94V-0	NOT TOOLED	12	94V-2	NOT TOOLED	12	94V-0
NOT TOOLED	42474-1412	14	94V-2	NOT TOOLED	42474-1422	14	94V-0	NOT TOOLED	14	94V-2	NOT TOOLED	14	94V-0
NOT TOOLED	42474-1612	16	94V-2	NOT TOOLED	42474-1622	16	94V-0	NOT TOOLED	16	94V-2	NOT TOOLED	16	94V-0
NOT TOOLED	42474-1812	18	94V-2	NOT TOOLED	42474-1822	18	94V-0	NOT TOOLED	18	94V-2	NOT TOOLED	18	94V-0
NOT TOOLED	42474-2012	20	94V-2	NOT TOOLED	42474-2022	20	94V-0	NOT TOOLED	20	94V-2	NOT TOOLED	20	94V-0
NOT TOOLED	42474-2212	22	94V-2	NOT TOOLED	42474-2222	22	94V-0	NOT TOOLED	22	94V-2	NOT TOOLED	22	94V-0
NOT TOOLED	42474-2412	24	94V-2	NOT TOOLED	42474-2422	24	94V-0	NOT TOOLED	24	94V-2	NOT TOOLED	24	94V-0

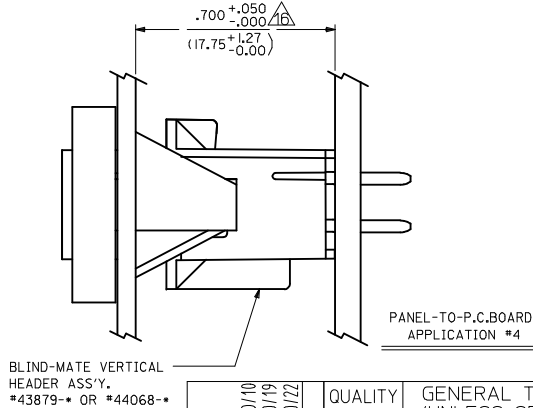
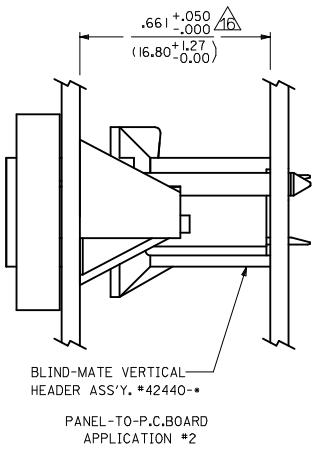
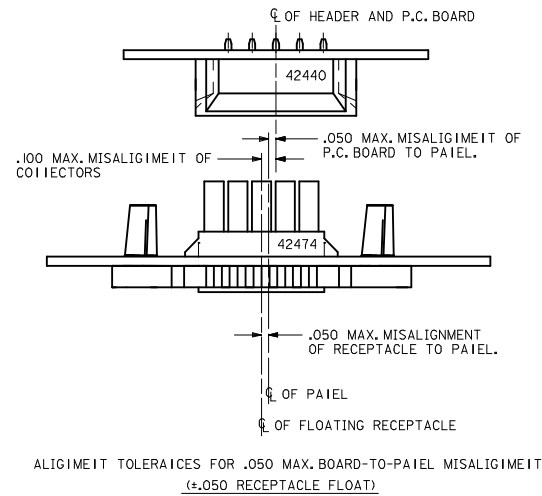
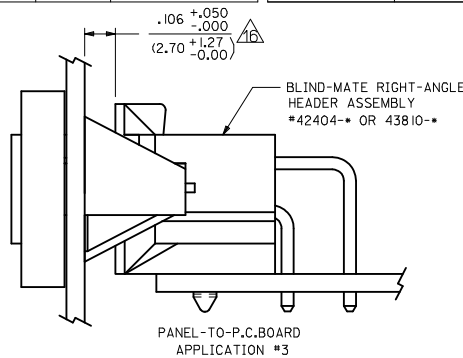
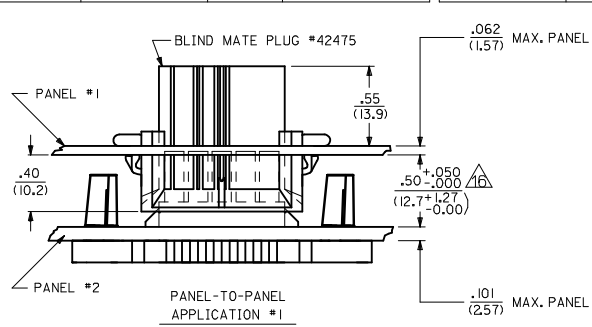

PANEL THICKNESS EC NO: UCP2008-0703 DRAWN: SCHMIDT 2007/10/10 CHKD: SSOUSEK 2007/10/19 APPR: F SMITH 2007/10/22	QUALITY SYMBOLS ▽=0 ▽=0	GENERAL TOLERANCES (UNLESS SPECIFIED)		DIMENSION STYLE IN/MM	SCALE 2:1	DESIGN UNITS METRIC	THIRD ANGLE PROJECTION	
		4 PLACES ± --- ± ---	3 PLACES ± --- ± .015	DRAWN BY JBS	DATE 2000/12/08	TITLE PANEL MNT RECEPTACLE MINI-FIT BMI SERIES FOR .094 MAX. THICK PANEL		
01	REV	2 PLACES ± 0.38 ± ---	1 PLACE ± --- ± ---	CHECKED BY BW	DATE 2000/12/08	MOLEX INCORPORATED		
		ANGULAR ±1/2°		APPROVED BY RE	DATE 2000/12/08	DOCUMENT NO. SD-42474-***2		
DRAFT WHERE APPLICABLE MUST REMAIN WITHIN DIMENSIONS		MATERIAL NO. SEE CHART		SHEET NO. 2 OF 2		THIS DRAWING CONTAINS INFORMATION THAT IS PROPRIETARY TO MOLEX INCORPORATED AND SHOULD NOT BE USED WITHOUT WRITTEN PERMISSION		