

# Spezifikation für Freigabe / specification for release

Kunde / customer :

Artikelnummer / part number :

**749053013**



Bezeichnung :

**LAN-Übertrager WE-LAN 10G**

description :

**LAN-Transformer WE-LAN 10G**

DATUM / DATE : 2017-10-13

**A Mechanische Abmessungen / dimensions :**

	<b>10G BaseT PoE+</b>
--	-----------------------

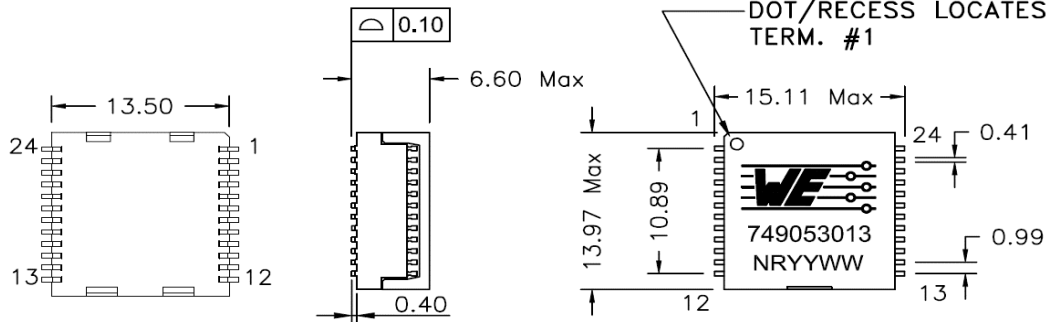

**B Elektrische Eigenschaften / electrical properties :**

Eigenschaften / properties	Testbedingungen / test conditions		Wert / value	Einheit / unit	tol.
Induktivität / Inductance	100kHz / 100mV @ 8mA DC-Bias	OCL	120	μH	min.
Übersetzungsverhältnis / Turns ratio	100kHz / 100mV	TR	1:1		±2%
Insertion Loss	100KHz-1MHz	IL	-3,0	dB	max.
	1MHz-250MHz		-1,0		
	250MHz-500MHz		-3,0		
Return Loss	1-40MHz	RL	-18,0	dB	min.
	100MHz		-16,0		
	200MHz		-13,0		
	250MHz		-11,2		
	400MHz		-10,0		
Common to Differential Mode Rejection	1MHz-100MHz	CDMR	-35,0	dB	min.
	100MHz-300MHz		-30,0		
	300MHz-500MHz		-25,0		
	1MHz-100MHz		-35,0		
Common to Common Mode Rejection	100MHz-250MHz	CMRR	-30,0	dB	min.
	250MHz-500MHz		-25,0		
	1MHz-100MHz		-40,0		
Crosstalk	100MHz-500MHz	CT	-30,0	dB	min.

**C Lötpad / soldering spec. :**

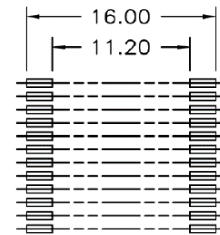

(SUGGESTED PCB PAD LAYOUT)

**D Prüfgeräte / test equipment :**

Agilent E5071C

**E Testbedingungen / test conditions :**

Luftfeuchtigkeit / Humidity: 33%  
Umgebungstemperatur / temperature: +25°C

**F Werkstoffe & Zulassungen / material & approvals :**

Basismaterial / Base material: Ferrit / Ferrite  
Draht / Wire: 0UEW/Y 180  
Kontaktmaterial / Contact plating: Cu-Ni-Sn  
Gehäuse / Case: UL94V-0  
Verguss / Potting: UL94V-0

**G Eigenschaften / general specifications :**

Betriebstemp. / Operating temperature: -40°C - +85°C  
Hochspannungsprüfung / Hipot test: 1500Vrms 1min.  
Feuchteempfindlichkeit: MSL 1 / Humidity class: MSL 1

Freigabe erteilt / general release:

	Kunde / customer			
.....	.....			
Datum / date	Unterschrift / signature			
.....	<b>Würth Elektronik</b>	JaB	Version 02	2017-10-13
.....	.....	JaB	Version 01	2016-08-09
.....	.....	JLiu	Version 00	2015-07-08
Geprüft / checked	Kontrolliert / approved	Name	Änderung / modification	Datum / date

**Würth Elektronik eiSos GmbH & Co.KG**

D-74638 Waldenburg · Max-Eyth-Straße 1 - 3 · Germany · Telefon (+49) (0) 7942 - 945 - 0 · Telefax (+49) (0) 7942 - 945 - 400  
http://www.we-online.com

# Spezifikation für Freigabe / specification for release

Kunde / customer :  
 Artikelnummer / part number : **749053013**  
 Bezeichnung : **LAN-Übertrager WE-LAN 10G**  
 description : **LAN-Transformer WE-LAN 10G**



DATUM / DATE : 2017-10-13

## H PoE Eigenschaften :

Designed für Applikationen bis 15W @57VDC  
 wenn zwei Kanäle bestromt  
 Designed für Applikationen bis 30W @57VDC  
 wenn alle vier Kanäle bestromt

## H PoE Specifications :

Designed to support applications up to 15W @57VDC  
 when using two channels  
 Designed to support applications up to 30W @57VDC  
 when using four channels

## I Schaltbild / Schematics :

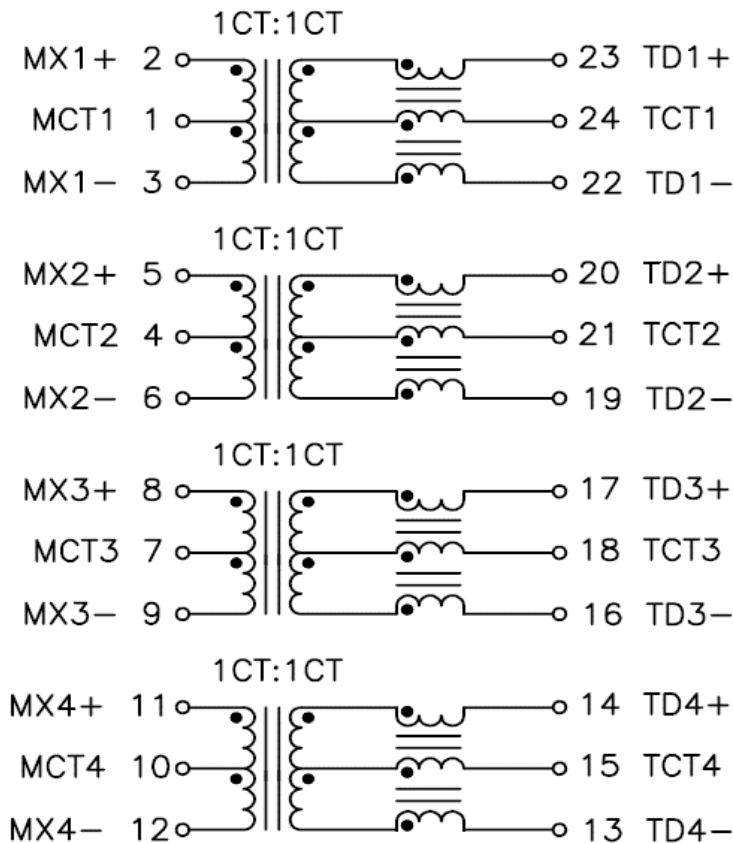

Freigabe erteilt / general release:	<b>Kunde / customer</b>			
.....	.....			
Datum / date	Unterschrift / signature			
.....	<b>Würth Elektronik</b>	JaB	Version 02	2017-10-13
.....	.....	JaB	Version 01	2016-08-09
.....	.....	JLiu	Version 00	2015-07-08
Geprüft / checked	Kontrolliert / approved	Name	<b>Änderung / modification</b>	Datum / date

This electronic component has been designed and developed for usage in general electronic equipment. Before incorporating this component into any equipment where higher safety and reliability is especially required or if

**Würth Elektronik eiSos GmbH & Co.KG**

D-74638 Waldenburg · Max-Eyth-Straße 1 - 3 · Germany · Telefon (+49) (0) 7942 - 945 - 0 · Telefax (+49) (0) 7942 - 945 - 400

<http://www.we-online.com>

# Spezifikation für Freigabe / specification for release

Kunde / customer :

Artikelnummer / part number :

749053013



Bezeichnung : LAN-Übertrager WE-LAN 10G

description : LAN-Transformer WE-LAN 10G

DATUM / DATE : 2017-10-13

**J Rollenspezifikation / tape and reel specification :**

Gurtspezifikation / Tape specification:

PACKAGING(Tape & Reel)

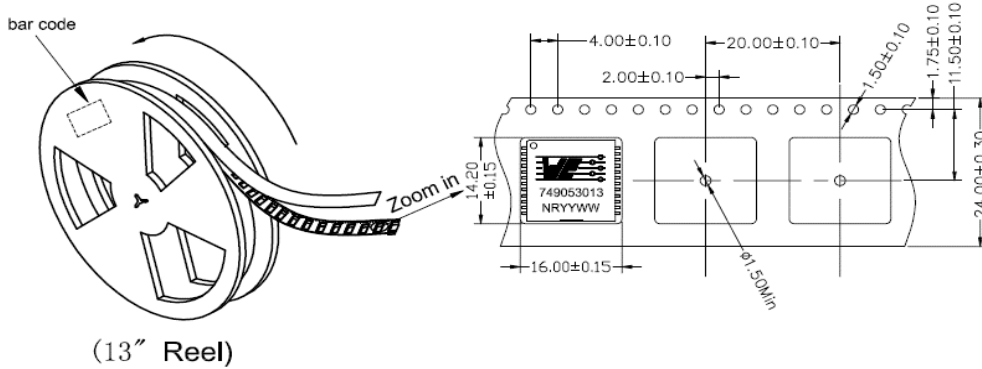

(13" Reel)

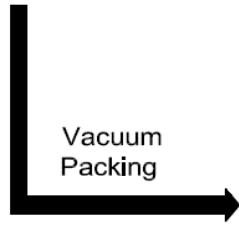

Outside Carton

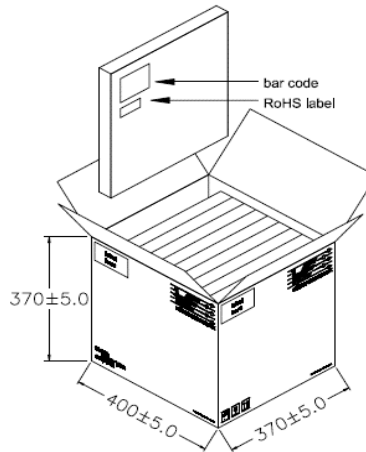

PACKING QUANTITY:

450pcs Finished Goods / Reel

10 Reels (4500pcs Finished Goods) / Carton

Freigabe erteilt / general release:

	<b>Kunde / customer</b>			
Datum / date	Unterschrift / signature			
	<b>Würth Elektronik</b>	JaB	Version 02	2017-10-13
		JaB	Version 01	2016-08-09
Geprüft / checked	Kontrolliert / approved	JLiu	Version 00	2015-07-08
		Name	<b>Änderung / modification</b>	Datum / date

This electronic component has been designed and developed for usage in general electronic equipment. Before incorporating this component into any equipment where higher safety and reliability is especially required or if

**Würth Elektronik eiSos GmbH & Co.KG**

D-74638 Waldenburg · Max-Eyth-Straße 1 - 3 · Germany · Telefon (+49) (0) 7942 - 945 - 0 · Telefax (+49) (0) 7942 - 945 - 400  
http://www.we-online.com





