

THIS DRAWING IS UNPUBLISHED. RELEASED FOR PUBLICATION
 © COPYRIGHT - TE Connectivity Ltd. ALL RIGHTS RESERVED.

P		LTR	DESCRIPTION	DATE	DWN	APVD
		A	INITIAL DRAWING	25SEP2019	VM	MP

Ordering Information

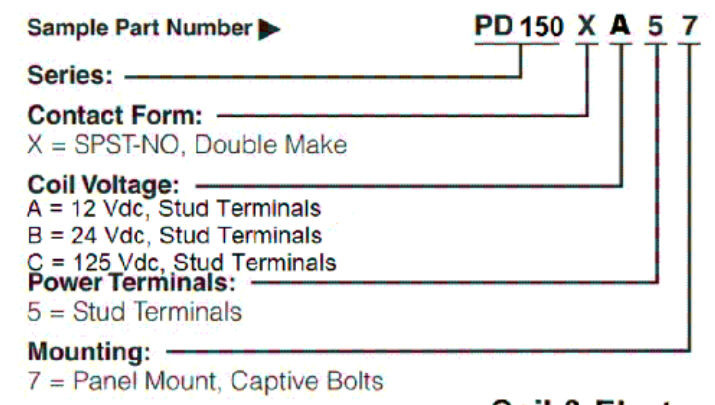

Schematic

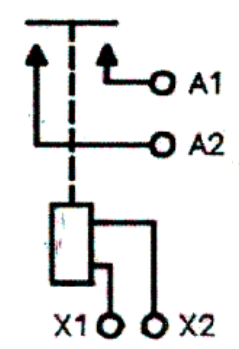

Part Drawing

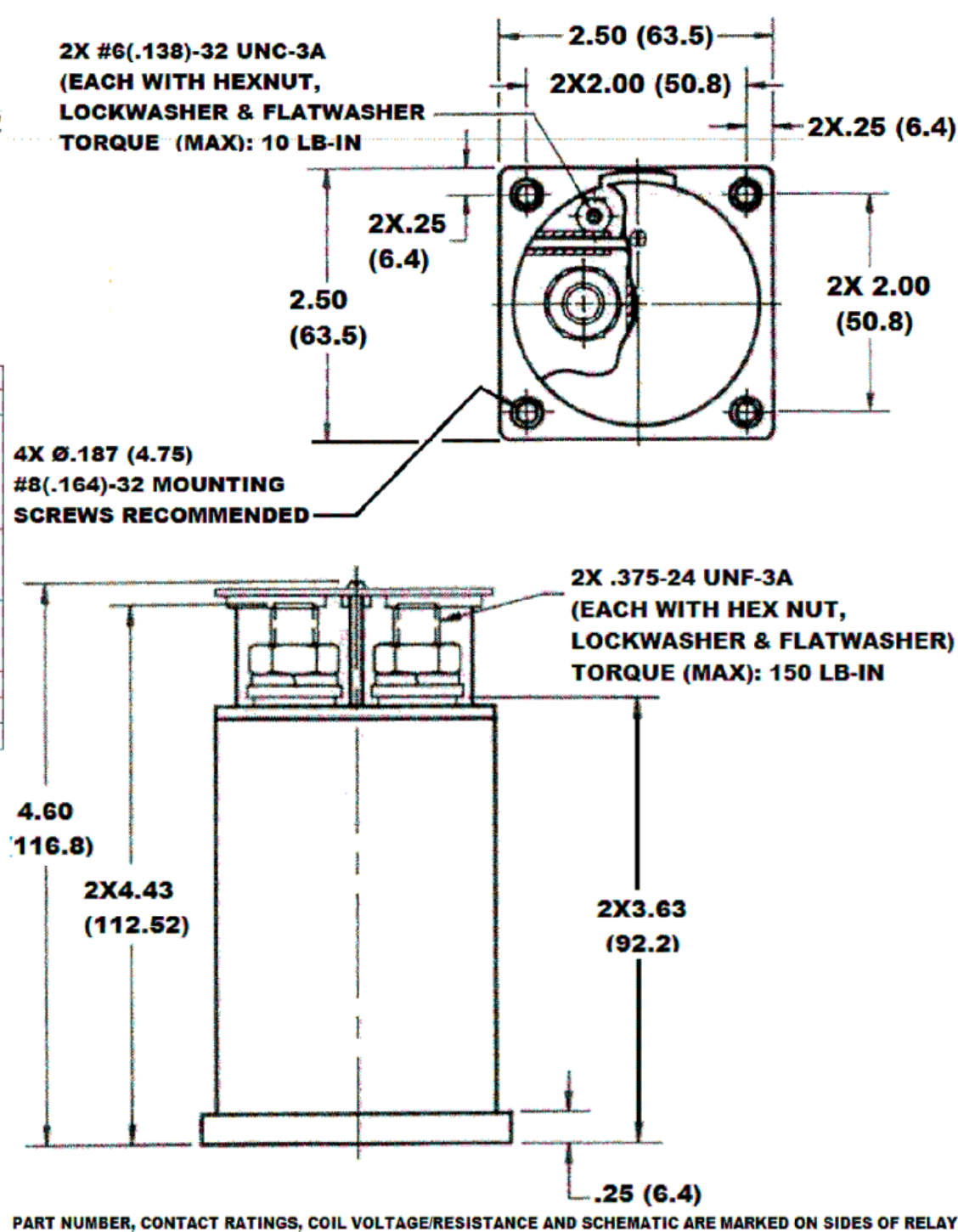

Features

- Physical:**
- Hermetically Sealed: arc contained
 - Maintenance free
- Environmental:**
- Temperature range -40°C to 85°C
 - 30G Shock
- Power Switching:**
- 320 Volts
 - 600A Carry
 - 3300A maximum interrupt

Coil & Electronics Data

	Units	PD150XA57	PD150XB57	PD150XC57
Coil Voltage, Nominal/Maximum	Vdc	12/12.5	24/28	125/145
Coil Resistance (± 10% @25°C)	Ω	9.6	52	960
Pickup Voltage, Maximum				
Cont. Current Test, High Temp. & Alt.	Vdc	9.9	22	115
High Temperature, Hot Coil	Vdc	9.5	21	111
High Temperature, Cold Coil	Vdc	8.6	19	86
Room Temperature, Cold Coil	Vdc	7.1	16.5	71
Dropout Voltage, Minimum				
Over Temperature Range	Vdc	0.5	1.0	5.0
@ 25 °C	Vdc	0.65	1.3	6.5
Hold Voltage, Minimum				
Over Temperature Range	Vdc	5	10	52
@ 25°C	Vdc	4.3	8.7	45
Contact Bounce, Maximum	mSec	8	8	8
Operate Time, Maximum	mSec	35	40	35
Release Time, Maximum	mSec	10	10	10

General Specifications

Physical Data	Units	
Contact Arrangement		SPST-NO
Form		X
Dimensions (L-W-H)	in.	2.5x2.5x4.6
Weight	oz.	26.5

Environmental Data		
Shock, 11ms ½ sine (operating)	G	25
Vibration, Sinusoidal (55-2000 Hz)	G	5
Operating Ambient Temperature Range	°C	-35to +65
Altitude, Maximum	Ft.	15000

Electrical Data		
Rated Operating Voltage	Vdc	250
Load Polarity		Bidirectional
Rated Resistive Load	Amps	150
Resistive Load Life	Cycles	10000
Rated Overload Current		
Beginning of Life (0 to 5k cycles)	Amps	500
End of Life (5k to 10k cycles)	Amps	400
Arc Duration, Nominal/Maximum	mSec	2/15
Overload Life	Cycles	10
Continuous Current Carry	Amps	150
Contact Resistance, Maximum	mΩ	1
Maximum Terminal Temperature	°C	200
Insulation Resistance @ 500 Vdc, Minimum	MΩ	100
Dielectric Strength @ Sea Level		
Coil to Power Terminals	Vrms	1800
All Other Points	Vrms	2000

1. Resistive load includes inductance L = 25uH.
2. For 600A carry use three 00 cables (203 mm²).
3. Testing is limited at this time. Consult factory for official ratings.
4. Operate Time, Release Time, and Contact Bounce are all measured with the relay stabilized at 25 C and operated with nominal coil voltage. Operate Time includes bounce. For normally closed relays, operate time refers to opening of the relay (i.e. operating the coil) and release time to closing the relay

PART NUMBER, CONTACT RATINGS, COIL VOLTAGE/RESISTANCE AND SCHEMATIC ARE MARKED ON SIDES OF RELAY

ALL DIMENSIONS ARE IN INCHES(MM)

THIS DRAWING IS A CONTROLLED DOCUMENT.		DWN VM 25SEP2019	TE Connectivity	
		CHK RV 25SEP2019		
		APVD MP 25SEP2019	NAME PD150X SERIES	
DIMENSIONS: INCHES		TOLERANCES UNLESS OTHERWISE SPECIFIED:		PRODUCT SPEC -
		0 PLC ± -	APPLICATION SPEC -	
		1 PLC ± -	SIZE A3	CAGE CODE -
		2 PLC ± -	DRAWING NO C-PD150X-SERIES	RESTRICTED TO -
		3 PLC ± -	CUSTOMER DRAWING	
MATERIAL -		FINISH -	WEIGHT -	SCALE NTS
				SHEET 1 OF 1
				REV A