

THIS DRAWING CONTAINS INFORMATION PROPRIETARY TO RF INDUSTRIES,
 ANY UNAUTHORIZED USE OF THIS DRAWING IS EXPRESSLY PROHIBITED
 WITHOUT WRITTEN PERMISSION FROM RF INDUSTRIES.
 ANY VIOLATION IS PUNISHABLE UNDER U.S. COPYRIGHT LAWS.

ALL DIMENSIONS ARE REFERENCE ONLY

PART NO.

RSB-4252-1B1

REV	DESCRIPTION	DWN	DATE	APPROVED
-	ENGINEERING RELEASE	CZS	3/3/03	JDMc

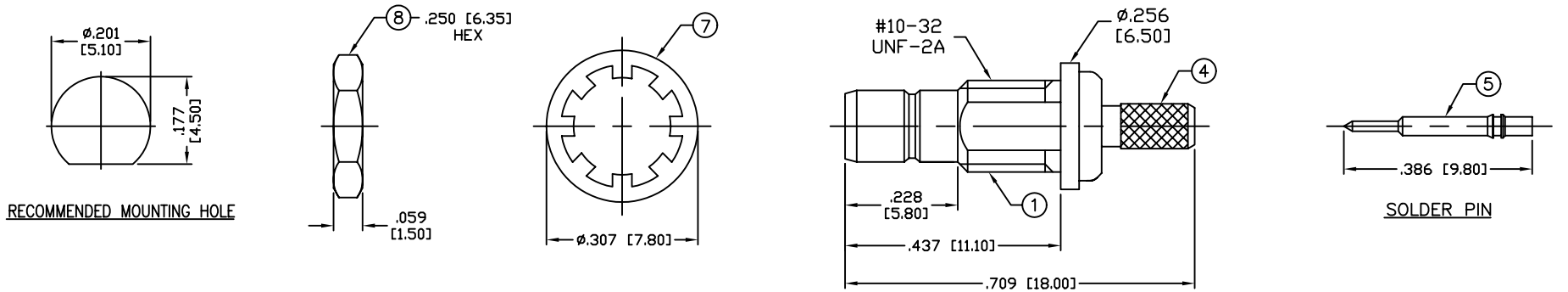

SPECIFICATIONS:

IMPEDANCE: 50 Ohms
 FREQUENCY RANGE: 0-4 GHz
 WORKING VOLTAGE: 335 V rms Max. @ Sea Level
 VSWR MAX: 1.15
 INSERTION LOSS(dB): $0.03 \times \sqrt{f(\text{GHz})}$
 CONTACT RESISTANCE: ≤ 6 m Ohm
 INSULATION RESISTANCE: 1k M Ohms min.
 TEMPERATURE RANGE: -65°C TO 165°C
 FOR RG-316/U DOUBLE SHIELD CABLE

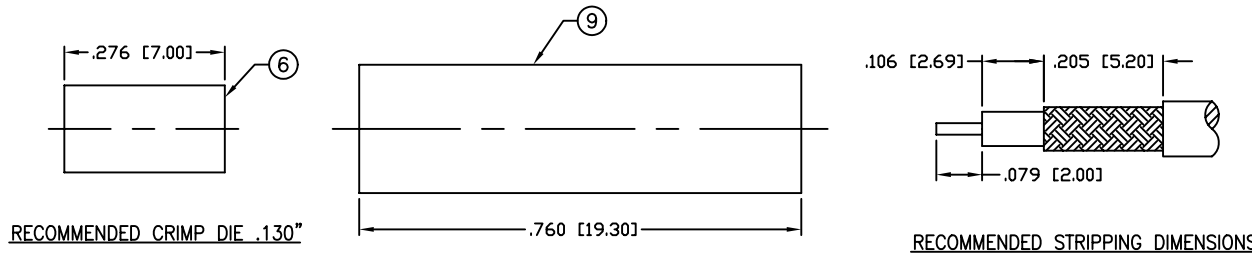

1	BODY	1	BRASS	GOLD, 3μ"
2	INSULATOR	1	PTFE	----
3	INSULATOR	1	PTFE	----
4	FERRULE STUD	1	BRASS	GOLD, 3μ"
5	PIN	1	BRASS	GOLD, 30μ"
6	FERRULE	1	COPPER	GOLD, 3μ"
7	LOCK WASHER	1	BRASS	GOLD, 3μ"
8	HEX NUT	1	BRASS	GOLD, 3μ"
9	TUBING	1	HEAT SHRINK	----
10				
11				
12				
13				
14				
#	DESCRIPTION	QTY	MATERIAL	FINISH

008974		
DRAWN	C. ZUNIGA	05/11/06
CHECKED		
ORJ DRAWN	C. ZUNIGA	05/11/06
APPROVALS	DATE	

UNLESS OTHERWISE SPECIFIED:
 1. REMOVE ALL BURRS
 2. BREAK ALL CORNERS & EDGES .005 R. MAX.
 3. CHAMFER 1ST & LAST THREADS 45°
 4. SURFACE ROUGHNESS 63 FINISH MIL-STD-10
 5. DIAMETERS ON COMMON CENTERS TO BE CONCENTRIC WITHIN .002 T.I.R.
 6. ALL DIMENSIONS ARE AFTER PLATING.

DIMENSIONS ARE IN INCHES AND [MILLIMETERS]
 UNLESS OTHERWISE NOTED TOLERANCES ARE:

DECIMALS	DIAMETER
.XXX±.003 [.08]	.XXX±.001 [.03]
.XX±.005 [.13]	.XX±.003 [.08]

7610 MIRAMAR RD
 SAN DIEGO, CA 92126
 (858) 549-6340
 (858) 549-6345 FAX

RF connectors
 DIVISION OF RF INDUSTRIES, LTD.

SMB JACK, CRIMP

BULKHEAD

SIZE	CABLE GROUP	DWG NO.	REV
A	B1	RSB-4252-1B1	-

SCALE: NTS CAD FILE OUTLINE SHEET 1 OF 1