

PART NUMBER	SML-LX0603SUGW-TR	REV.	F
DATE	E.C.N. NUMBER AND REVISION COMMENTS	REV.	
12.03.02	E.C.N. #10933.	A	
03.14.03	E.C.N. #10967.	B	
12.06.04	E.C.N. #11148.	C	
03.05.09	E.C.N. #11508.	D	
12.01.10	E.C.N. #11685.	E	
11.14.19	ECN-Lumex201900133	F	

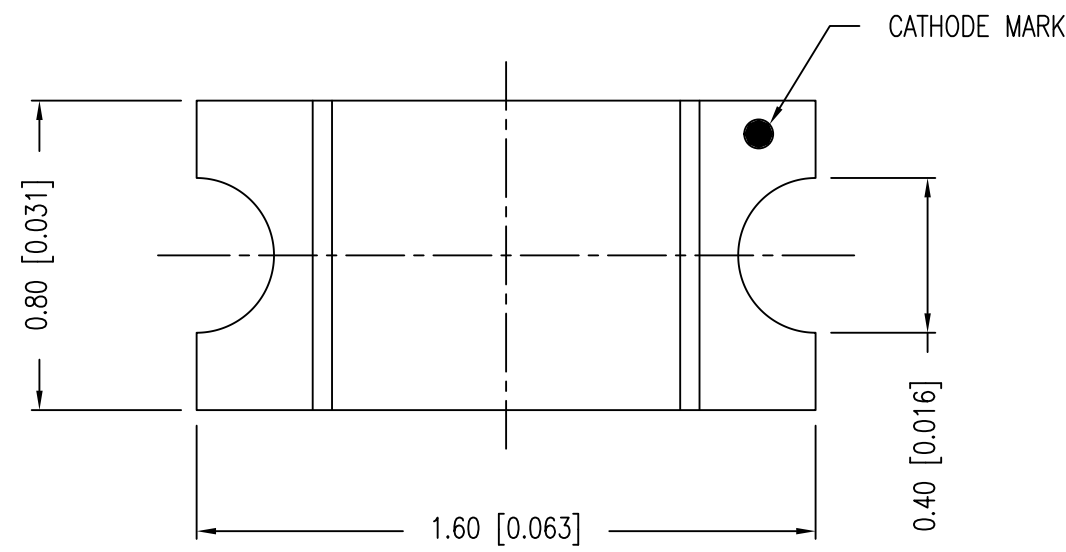

CATHODE MARK

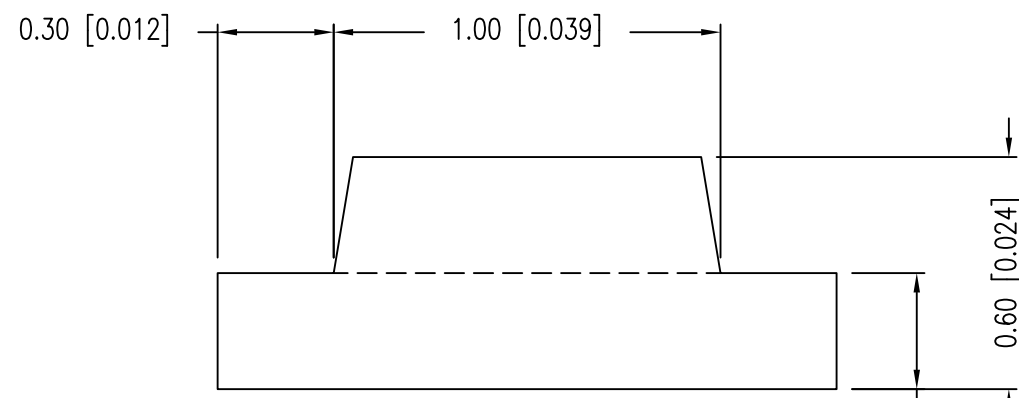

0.30 [0.012]

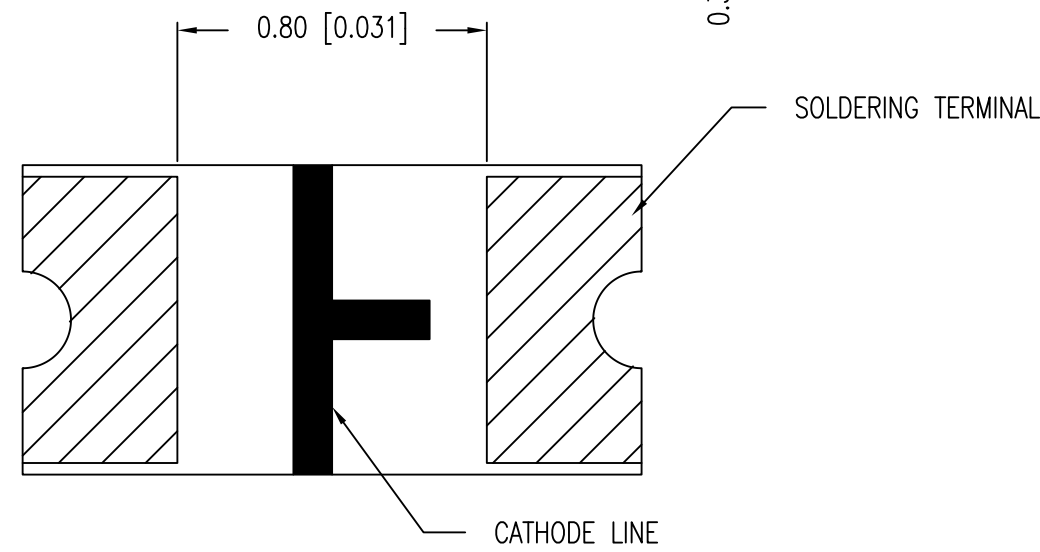

SOLDERING TERMINAL

CATHODE LINE

**C** LEAD FREE REFLOW PROFILE

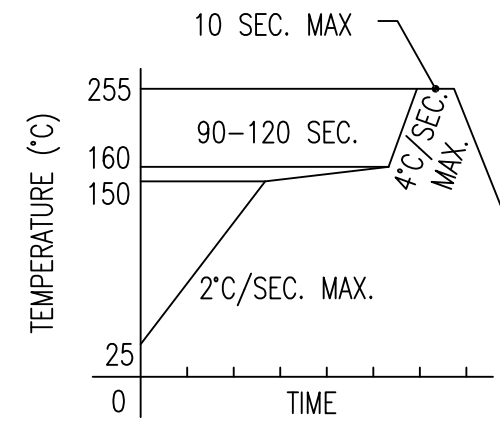

TOTAL TIME ABOVE 220°C IS 60 SECONDS MAX.

**E** ELECTRO-OPTICAL CHARACTERISTICS  $T_A=25^\circ\text{C}$   $I_f=20\text{mA}$

PARAMETER	MIN	TYP	MAX	UNITS	TEST COND
PEAK WAVELENGTH		574		nm	
FORWARD VOLTAGE		2.0	2.4	$V_f$	
REVERSE VOLTAGE	5.0			$V_r$	$I_f=100\mu\text{A}$
AXIAL INTENSITY		71.5		mcd	$I_f=20\text{mA}$
VIEWING ANGLE		140		2x theta	
EMITTED COLOR:	GREEN				
EPOXY LENS FINISH:	MILKY WHITE DIFFUSED				

**E** LIMITS OF SAFE OPERATION AT 25°C

PARAMETER	MAX	UNITS
PEAK FORWARD CURRENT*	100	mA
STEADY CURRENT	30	mA
POWER DISSIPATION	72	mW
DERATE FROM 25°C	-1.2	mW/°C
OPERATING TEMP.	-30 TO +80	°C
STORAGE TEMP.	-40 TO +85	°C

\*  $t < 10\mu\text{s}$

NOTES:

1. THE CATHODE MARK IS ORIENTED TOWARDS THE SPROCKET HOLE.

**F** CAUTION: MOISTURE SENSITIVE DEVICE  
**B** PER JEDEC LEVEL 2a STANDARDS

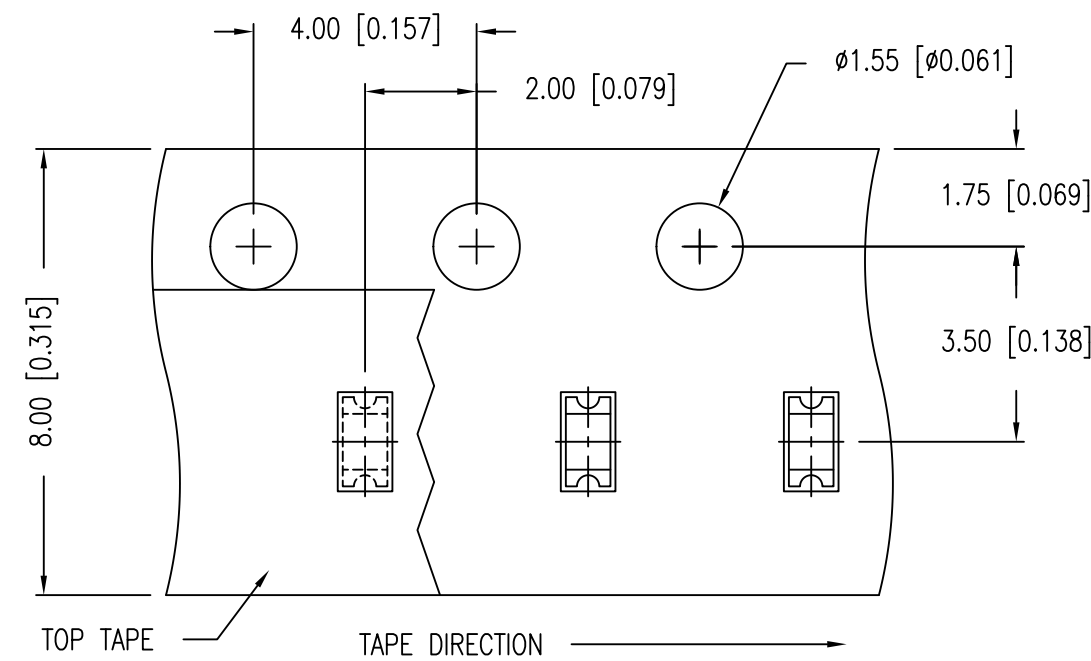

RECOMMENDED SOLDER PAD LAYOUT

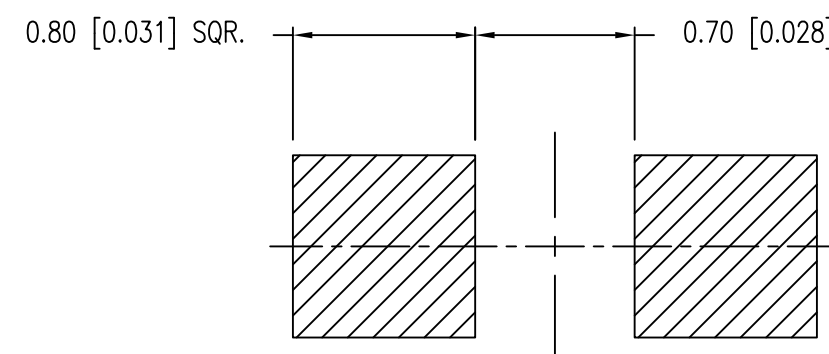

\*UNLESS OTHERWISE SPECIFIED TOLERANCES PER DECIMAL PRECISION ARE: X=±1 (±0.039), X.X=±0.5 (±0.020), X.XX=±0.25 (±0.010), X.XXX=±0.127 (±0.005). LEAD SIZE=±0.05 (±0.002), LEAD LENGTH=±0.75 (±0.030). MIN= +DECIMAL PRECISION -0.00 MAX.= +0.00 -DECIMAL PRECISION UNCONTROLLED DOCUMENT



425 N. GARY AVE.  
CAROL STREAM, IL 60188  
PHONE: 800-278-5666  
FAX: 630-315-2150  
WEB: WWW.LUMEX.COM

1.6mm x 0.8mm PCB CHIP, SURFACE MOUNT LED, 574 SUPER ULTRA GREEN LED, MILKY WHITE DIFFUSED LENS.

\*\*THE SPECIFICATIONS MAY CHANGE AT ANY TIME WITHOUT NOTICE.\*\*

CONFIDENTIAL INFORMATION

THE INFORMATION CONTAINED IN THIS DOCUMENT IS THE PROPERTY OF LUMEX INC. EXCEPT AS SPECIFICALLY AUTHORIZED IN WRITING BY LUMEX INC., THE HOLDER OF THIS DOCUMENT SHALL KEEP ALL INFORMATION CONTAINED HEREIN CONFIDENTIAL AND SHALL PROTECT SAME IN WHOLE OR IN PART FROM DISCLOSURE AND DISSEMINATION TO ALL THIRD PARTIES.

DATE:	11.14.19	DRAWN BY:	C.S.
PAGE:	1 OF 1	CHKD BY:	E.C.
SCALE:		APRVD BY:	G.Y.
UNIT:	mm [INCH]		(Rb)