

APPROVAL SHEET



WLSS528P Series
Shielded SMD Power Inductors

*Contents in this sheet are subject to change without prior notice.

Features

1. Shielded power inductor.
2. Wide inductance range.

Applications

1. Inductor in DC/DC converter.
2. Use in STB、PDA、Notebook.

Shape and Dimension

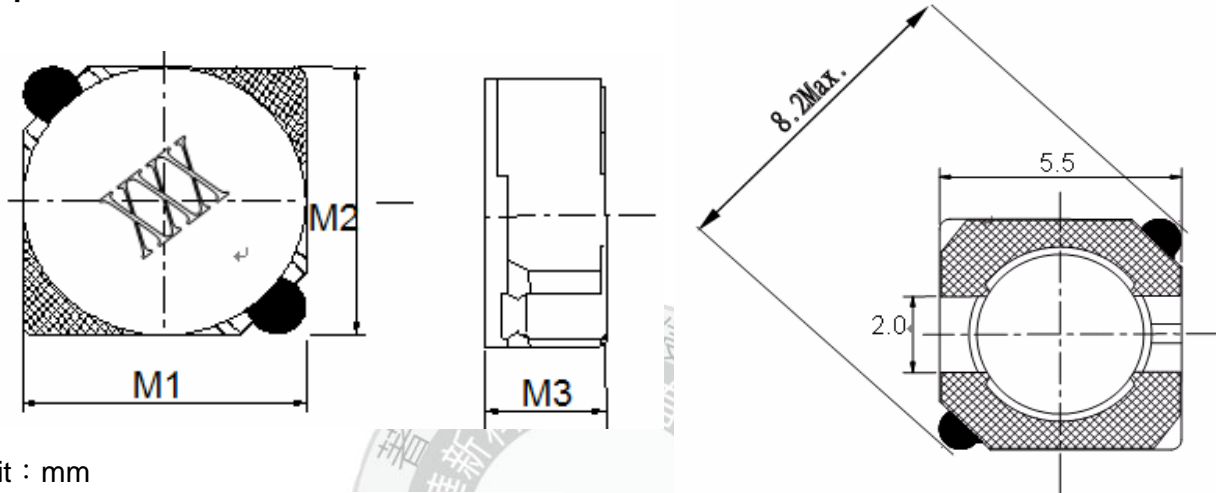

Unit : mm

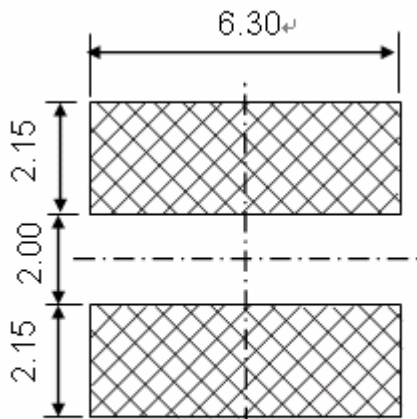

Recommended Patterns

	DIM.	TOL.
M1	5.7	±0.3
M2	5.7	±0.3
M3	3.0	MAX.

Ordering Information

WL	SS	528P	Z0	N	2R5	L	B
Product Code	Series	Dimensions	Series extension	Tolerance	Value	Packing Code	
WL: Inductor	Shielded SMD Power Inductors	5.7 * 5.7 mm	Z0:STD	N: ± 30%	2R5 = 2.5uH 100 = 10.0uH 101 =100uH	L=13" Reeled (Embossed tape)	B:STD

Electrical Characteristics

WLSS528P Series	Marking	L (uH)	Inductance Tolerance	Test Freq (KHz)	DCR (mΩ) MAX.	Rated Current (A)
WLSS528PZ0N2R5LB	2R5	2.5	±30%	10	18	2.60
WLSS528PZ0N3R0LB	3R0	3.0	±30%	10	24	2.40
WLSS528PZ0N4R2LB	4R2	4.2	±30%	10	31	2.20
WLSS528PZ0N5R3LB	5R3	5.3	±30%	10	38	1.90
WLSS528PZ0N6R0LB	6R2	6.2	±30%	10	45	1.80
WLSS528PZ0N8R2LB	8R2	8.2	±30%	10	53	1.60
WLSS528PZ0N100LB	100	10	±30%	10	65	1.30
WLSS528PZ0N120LB	120	12	±30%	10	76	1.20
WLSS528PZ0N150LB	150	15	±30%	10	103	1.10
WLSS528PZ0N180LB	180	18	±30%	10	110	1.00
WLSS528PZ0N220LB	220	22	±30%	10	122	0.90
WLSS528PZ0N270LB	270	27	±30%	10	175	0.85
WLSS528PZ0N330LB	330	33	±30%	10	189	0.75
WLSS528PZ0N390LB	390	39	±30%	10	212	0.70
WLSS528PZ0N470LB	470	47	±30%	10	250	0.62
WLSS528PZ0N560LB	560	56	±30%	10	305	0.58
WLSS528PZ0N680LB	680	68	±30%	10	355	0.52
WLSS528PZ0N820LB	820	82	±30%	10	463	0.46
WLSS528PZ0N101LB	101	100	±30%	10	520	0.42

TEST INSTRUMENT: HP4284A 、 ZENTECH502BC / Chroma3302,1320

- a. Tolerance : N:±30%
- b. Operating Temp : -25°C to +105°C.
- c. Inductance measured using the HP4284A LCR meter, CHROMA 1320 & 3302 & 16502.
- d. DCR measured using the 502BC milli-ohm meter.
- e. Inductance drops no more than 35% of initial value at rated current, temperature rises $\Delta t < 40^\circ\text{C}$.
- f. MSL : LEVEL 1

TYPICAL RoHS REFLOW PROFILE

Typical RoHS Reflow Profile

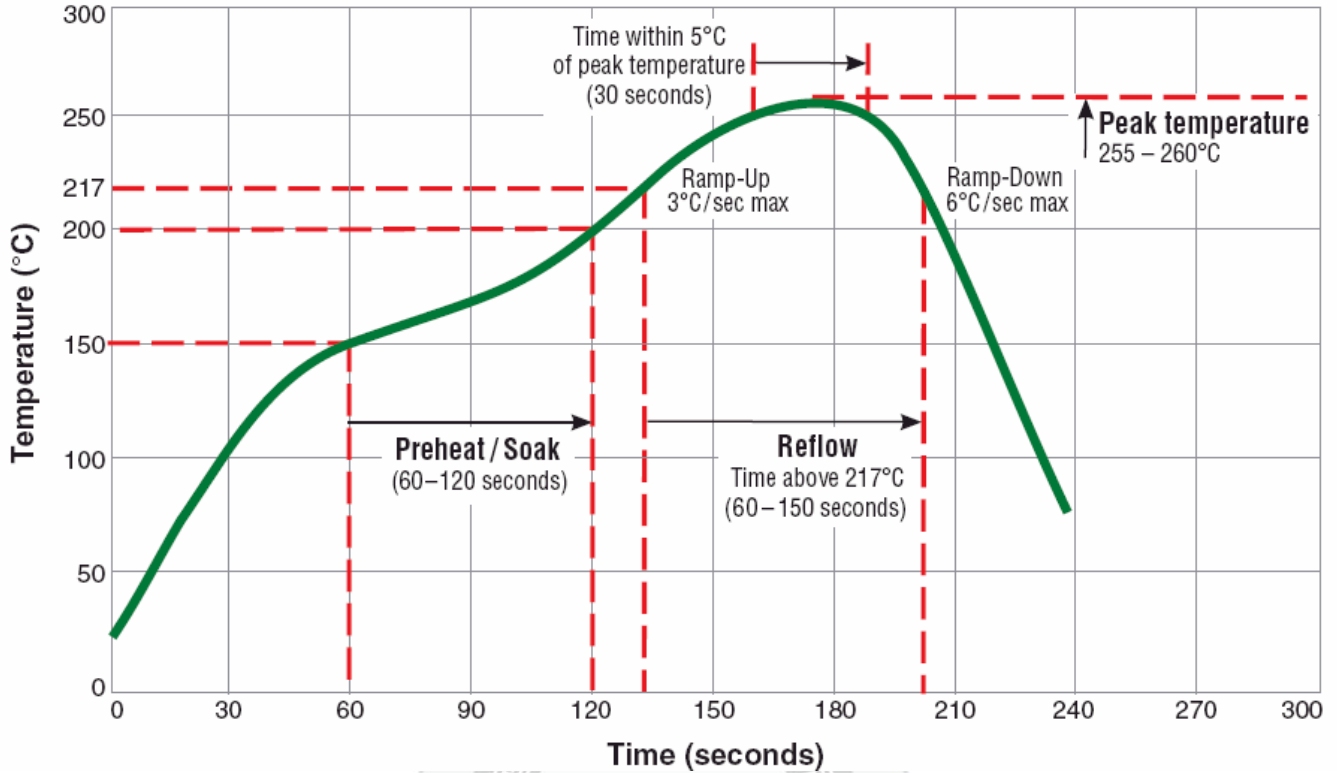

RELIABILITY PERFORMANCE

Reliability Experiment For Electrical

Test Item	Test Condition	Standard Source
Humidity Test	+40°C ± 2°C, humidity of 90% ± 5% (total 96 hours).	MIL-STD-202G Method 103B Test Condition B
High Temperature Test	1. Temperature: +125°C ± 2°C 2. Test time: 48 ± 2hrs	IEC 68-2 Test Condition B
Low Temperature Test	1. Temperature: -40°C ± 2°C 2. Test time: 48 ± 2hrs	IEC 68-2 Test Condition A
Thermal Shock	+125°C ± 5°C (30 minutes) ~ -40 ± 5°C (30 minutes), temperature switch time: 5 minutes (total 50 cycles).	MIL-STD-202G Method 107G Test Condition B-2
Life Test	+70°C ± 5°C (250Hours)	MIL-STD-202G Method 108A Test Condition B

Reliability Experiment For Physical

Test Item	Test Condition	Standard Source
Vibration Test	10-55-10HZ, amplitude: 1.5mm, direction: X, Y, Z axes, each axis 2 hours (total 6 hours).	MIL-STD-202G Method 201A
Solder Heat Resistance Test	IR/convection reflow: Peak Temp 250 ± 5°C for 5Sec in air, Through 2 Cycle. Temperature Ramp: +1~4°C/sec; Above 183°C, must keep 90 s - 120 s	MIL-STD-202G Method 210F Test Condition (Reflow)
Solder Ability Test	Soak in 245 °C solder pot of 3Sec, PAD must have 95% above coverage.	J-STD-003B

Tape & Reel Packaging Dimensions:

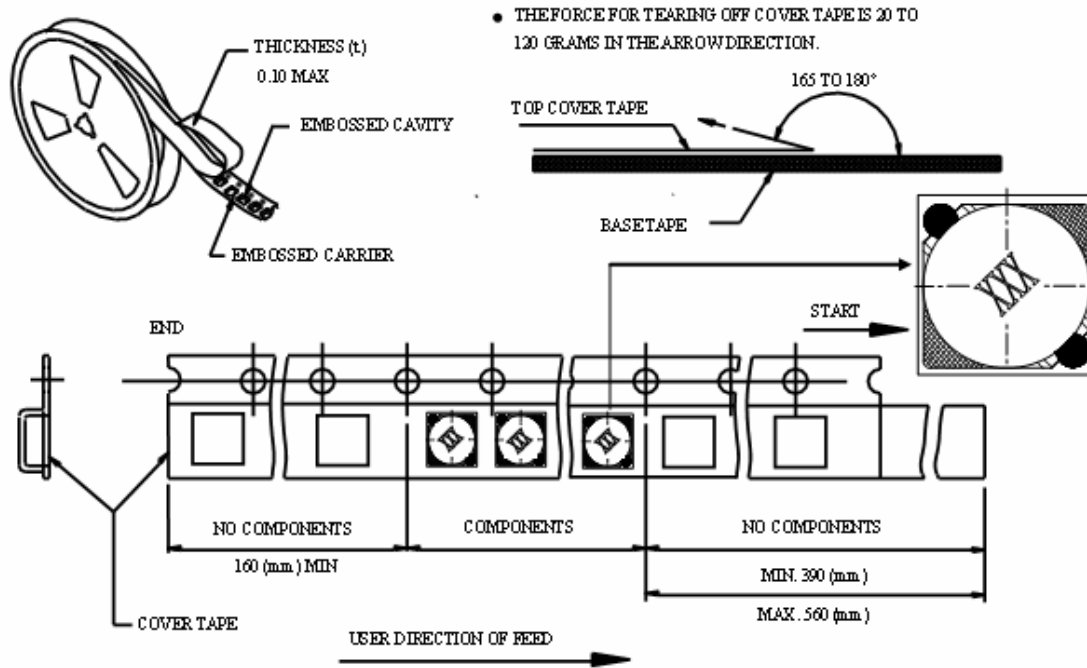

■ CARRIER TAPE REELS (mm)

MATERIAL: PLASTIC

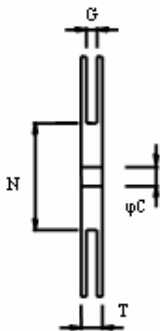
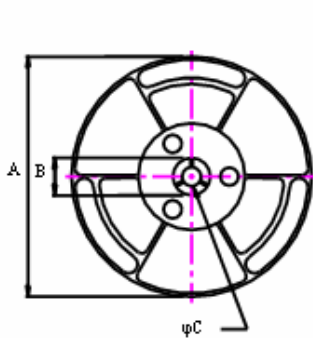

■ DIMENSIONS OF CARRIER TAPE (mm)

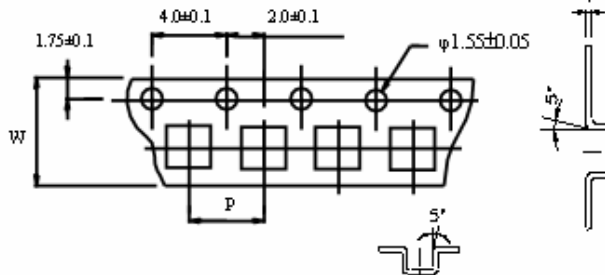

∴ 10 sprocket hole pitch cumulative tolerance ± 0.20

Unit : mm

	A	B	C	G	N	P	T	W	t
DIM.	340	21.0	13.0	16.4	60	12.0	22.4	16	0.35
TOL.	MAX	± 0.8	± 0.5	± 0.2	MIN	± 0.1	MAX	± 0.3	± 0.05

Quantity per reel : 1.5K pcs