



MAX9636 Evaluation Kit

General Description

The MAX9636 evaluation kit (EV kit) is an assembled and tested PCB used to evaluate the MAX9636 low-power, low-noise, CMOS input op amp, which is suitable for photodiode transimpedance front-ends in portable medical instruments. The EV kit is preconfigured for a transimpedance amplifier (TIA). Additionally, an on-board LED driver circuit provides a controlled light source to help evaluate the performance of the MAX9636 TIA circuit. The EV kit can easily be adapted to act as noninverting, inverting, or differential amplifier by changing a few components. Another EV kit is offered for the MAX9638 dual version of this op amp to enable evaluation in an active filter circuit configuration.

The EV kit comes with a MAX9636AXT+ installed.

Features

- ◆ Accommodates Multiple Op-Amp Configurations
- ◆ On-Board LED Driver
- ◆ Accommodates Multiple Wavelength LEDs
- ◆ Proven PCB Layout
- ◆ Fully Assembled and Tested

Ordering Information

PART	TYPE
MAX9636EVKIT+	EV Kit

+Denotes lead(Pb)-free and RoHS compliant.

Component List

DESIGNATION	QTY	DESCRIPTION
C1	1	18pF $\pm 5\%$, 50V C0G ceramic capacitor (0603) TDK C1608C0G1H180J
C2, C7, C8, C9	4	0.1 μ F $\pm 10\%$, 16V X7R ceramic capacitors (0603) Murata GRM188R71C104K
C3, C6	0	Not installed, ceramic capacitors (0603)
C4	0	Not installed, ceramic capacitor (0805)
C5	1	4.7 μ F $\pm 10\%$, 25V X5R ceramic capacitor (0805) Murata GRM21BR61E475K
D1	1	Red side LED (4mm x 3.6mm x 4mm) OSRAM LS A676-R1S1

DESIGNATION	QTY	DESCRIPTION
D2	1	Photodiode Vishay BPW46
JU1, JU2	2	3-pin headers
M1	1	n-channel MOSFET (6 SC70) Fairchild FDG410NZ
R1, R6, R7	3	0 Ω $\pm 5\%$ resistors (0603)
R2	1	10k Ω $\pm 1\%$ resistor (0603)
R3, R9, R12	0	Not installed, resistors (0603)
R4	1	100k Ω $\pm 1\%$ resistor (0603)
R5	1	249 Ω $\pm 1\%$ resistor (0603)
R8, R10, R11	3	976 Ω $\pm 1\%$ resistors (0603)
TP1	1	Red test point
U1, U2	2	Low-power op amps (6 SC70) Maxim MAX9636AXT+
—	2	Shunts
—	1	PCB: MAX9636 EVALUATION KIT+

Component Suppliers

SUPPLIER	PHONE	WEBSITE
Fairchild Semiconductor	888-522-5372	www.fairchildsemi.com
Murata Electronics North America, Inc.	770-436-1300	www.murata-northamerica.com
TDK Corp.	847-803-6100	www.component.tdk.com
Vishay	402-563-6866	www.vishay.com

Note: Indicate that you are using the MAX9636 when contacting these component suppliers.



MAX9636 Evaluation Kit

Quick Start

Required Equipment

- MAX9636 EV kit
- 2.1V to 5.5V DC power supply (e.g., Agilent E3620A)
- Function generator (e.g., Agilent 33220A)
- Digital oscilloscope (e.g., Tektronix TDS3014)

Procedure

The EV kit is fully assembled and tested. Follow the steps below to verify board operation. **Caution: Do not turn on power supply until all connections are completed.**

- 1) Since the photodiode on the EV kit is sensitive to ambient and infrared light, it is recommended that the EV kit be placed in a suitable dark environment to minimize the idling current.
- 2) Verify that a shunt is installed in the 1-2 position of both jumpers JU1 and JU2. See Table 1 for a description of the jumper settings.
- 3) Set the DC power supply to 5V and connect the positive terminal to the VDD and INP pads on the EV kit. Connect the negative terminal to the GND pad.
- 4) Set the function generator for a square-wave frequency of 1kHz, and amplitude to 2VP-P with a DC offset of 1V.
- 5) Disable the function generator.
- 6) Connect the function generator across the VCONTROL and GND pads on the EV kit.
- 7) Connect an oscilloscope channel across the VOUT and GND pads on the EV kit.
- 8) Turn on the DC power supply.
- 9) Enable the function generator.

- 10) Verify that the red LED (D1) turns on. At 1kHz, the LED pulsing cannot be seen due to persistence of vision. Verify that the oscilloscope screen shows a square waveform with an approximate 1kHz frequency.

Detailed Description of Hardware

The MAX9636 EV kit is an assembled and tested PCB used to evaluate the MAX9636 low-power op amp, which is suitable for photodiode transimpedance front-ends in portable medical instruments. The EV kit is preconfigured for a TIA, but can easily be adapted to other topologies by changing a few components.

Transimpedance Amplifier (TIA)

By default, the EV kit is set up for a TIA. The output voltage of the TIA is the photodiode current multiplied by the feedback resistor:

$$V_{OUT} = (I_{PD} \times R_4) + V_{OS}$$

where R4 comes installed as a 100kΩ resistor, I_{PD} is defined as photodiode current, and V_{OS} is the input offset voltage of the op amp. Use capacitor C1 to stabilize the op amp by rolling off high-frequency gain due to the photodiode capacitance.

For ease of evaluation of the TIA circuit, LED D1 is provided on-board to emit light from the side. A second op amp (U2), MOSFET M1, and resistors R8, R10, and R11 form a controlled current-sink circuit to regulate the LED current. Due to the negative feedback action, the voltage at test point TP1 is the same as the control voltage (VCONTROL). The LED current is given by the following equation:

$$I_{LED} = \frac{V_{CONTROL}}{(R_8 || R_{10} || R_{12})}$$

Table 1. Jumper Descriptions (JU1, JU2)

JUMPER	SHUNT POSITION	DESCRIPTION
JU1	1-2*	Connects the \overline{SHDN} pin of the MAX9636 (U1) to VDD for normal operation.
	2-3	Connects the \overline{SHDN} pin of the MAX9636 (U1) to GND to put the part in shutdown mode.
JU2	1-2*	Powers LED D1 using the supply applied at the VDD pad of the EV kit.
	2-3	Powers LED D1 and its LED driver circuit using a separate power supply applied at the VLED pad on the EV kit.

*Default position.

MAX9636 Evaluation Kit

Since the forward-voltage drop across the LED is approximately 2V, the applied control voltage ranges from 0V to VDD1 - 2V.

The silicon pin photodiode (BPW46) has a spectral bandwidth that ranges from 430nm to 1100nm. Hence, the EV kit can also be used with LEDs that range from visible light to infrared light. Table 2 gives a list of LEDs that have the same footprint as installed LED D1, but with different wavelengths. When changing D1, replace R8, R10, R11, and R12 with the appropriate resistor values.

Noninverting Configuration

The EV kit can also be configured as a noninverting amplifier. Remove D2, R5, C1, and C2 from the EV kit. Replace R2 with a 0Ω resistor. The gain is set by the ratio of R4 and R1 when a voltage (VINP) is applied at the INP pad and the INM pad is connected to ground by installing 0Ω on R9 on the EV kit. The output voltage for the noninverting configuration is given by the following equation:

$$V_{OUT} = \left(1 + \frac{R4}{R1}\right)(V_{INP} + V_{OS})$$

Inverting Configuration

The EV kit can also be configured as an inverting amplifier. Remove D2, R2, R5, and R6 from the EV kit. Install a 0Ω resistor across R5 and R3. Install the decoupling capacitors between C4 and C6. The board is operated in dual supply (±1.05V to ±2.75V). The gain is set by the ratio of R4 and R1 when a voltage (VINM) is

applied at the INM pad. The output voltage for the inverting configuration is given by the following equation:

$$V_{OUT} = \left(-\frac{R4}{R1}\right)(V_{INM} + V_{OS})$$

Differential Amplifier

To configure the EV kit as a differential amplifier, remove D2 and replace R1, R2, R4, and R5 with the appropriate resistors. Remove or choose appropriate equal capacitors for C1 and C5. When R1 = R2 and R4 = R5, the CMRR of the differential amplifier is determined by matching of ratios R1/R2 and R4/R5.

$$V_{OUT} = A_V (V_{INP} - V_{INM})$$

where:

$$A_V = \frac{R4}{R1} = \frac{R5}{R2}$$

Shutdown (SHDN)

The MAX9636 (U1) is operational when a shunt is placed in the 1-2 position on jumper JU1. By placing a shunt in the 2-3 position, U1 is disabled.

LED Supply

By default, the LED D1 supply uses the same supply applied at the VDD pad on the EV kit. To use a separate supply for the LED circuit, move the shunt of jumper JU2 to the 2-3 position and apply a voltage from 2.1V to 5.5V on the VLED pad on the EV kit.

Table 2. List of LEDs With the Same Footprint as D1

LED MANUFACTURER PART NUMBER	WAVELENGTH (nm)	COLOR
OSRAM LB A6SG-S1T2-35	470	Blue
OSRAM LT A673-Q1R2-25	532	Green
OSRAM LY A676-R1S2-26	587	Yellow
OSRAM LO A676-R1S2-24	606	Orange
OSRAM LA A676-R1S2-1	615	Amber
OSRAM SFH426	880	Infrared
OSRAM SFH425	950	Infrared

MAX9636 Evaluation Kit

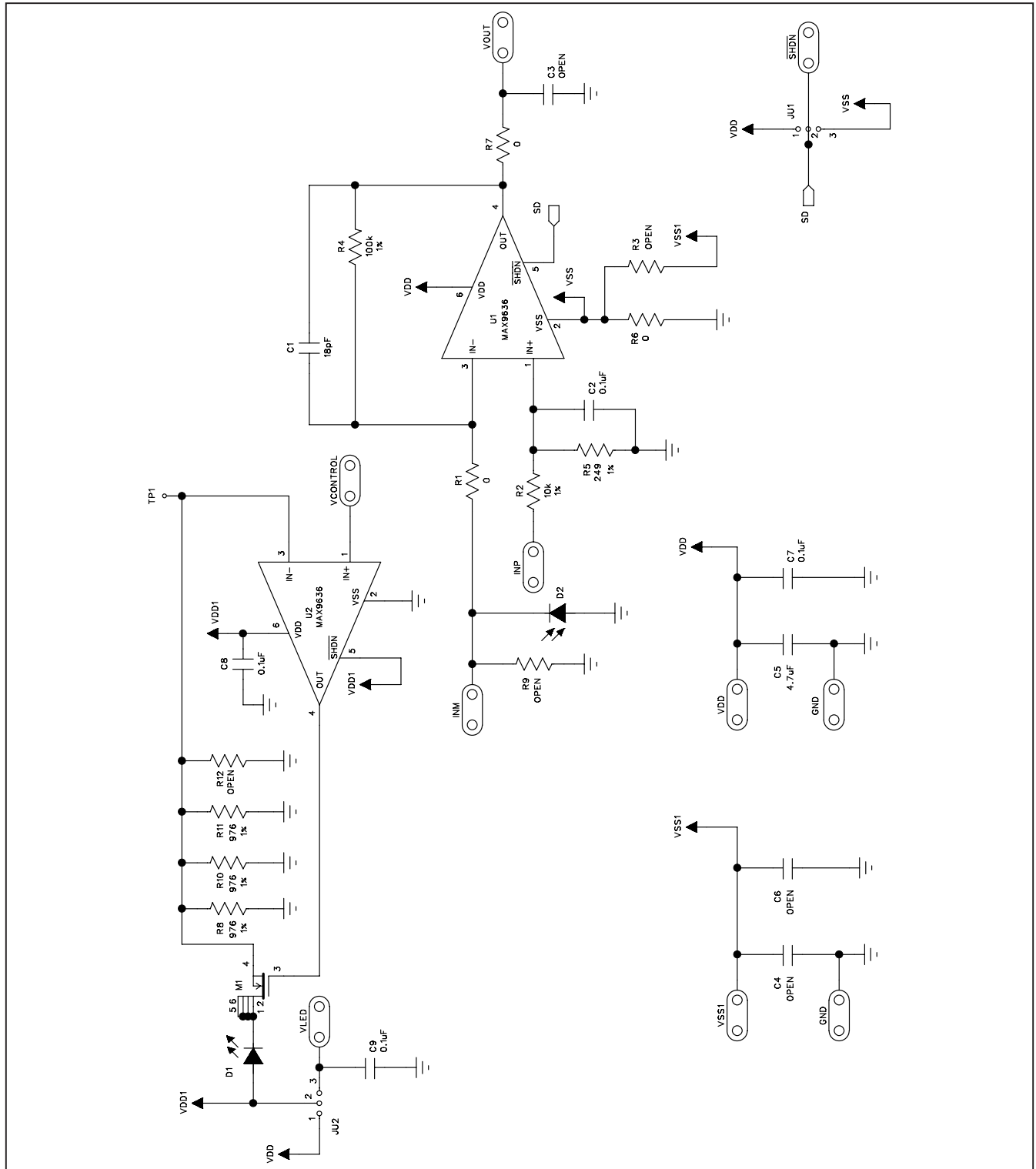

Figure 1. MAX9636 EV Kit Schematic

MAX9636 Evaluation Kit

Evaluates: MAX9636

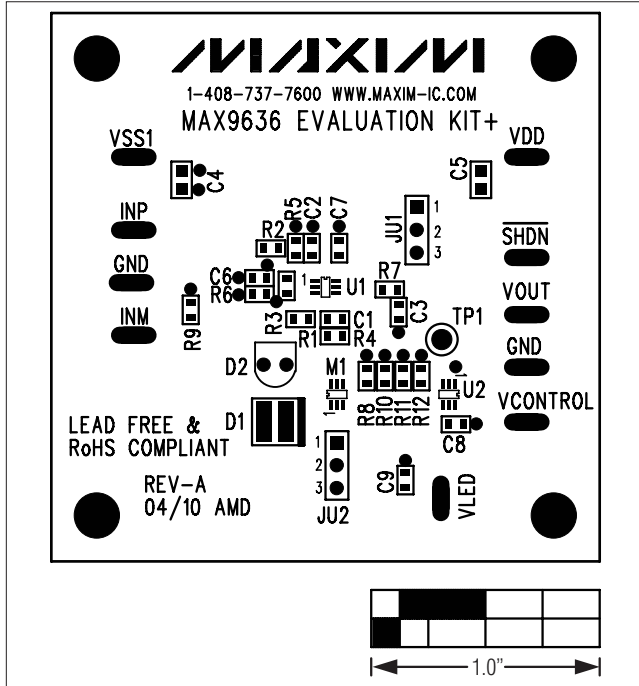

Figure 2. MAX9636 EV Kit Component Placement Guide—Component Side

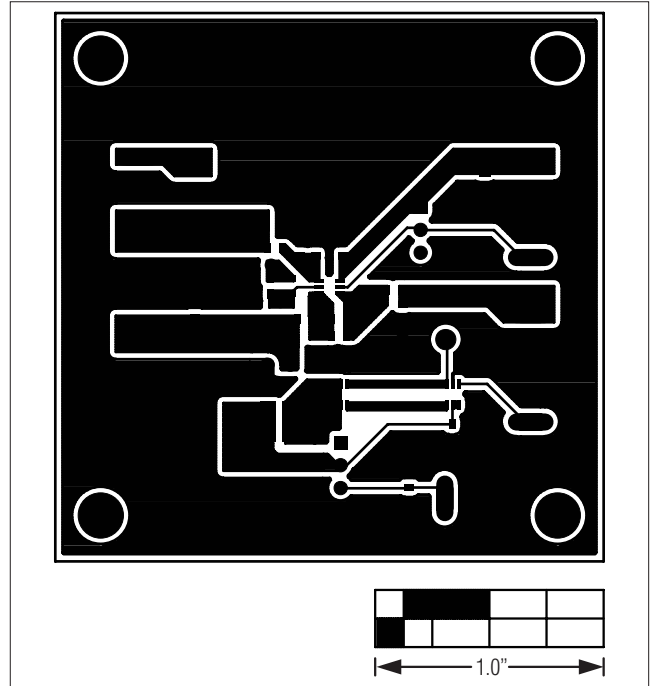

Figure 3. MAX9636 EV Kit PCB Layout—Component Side

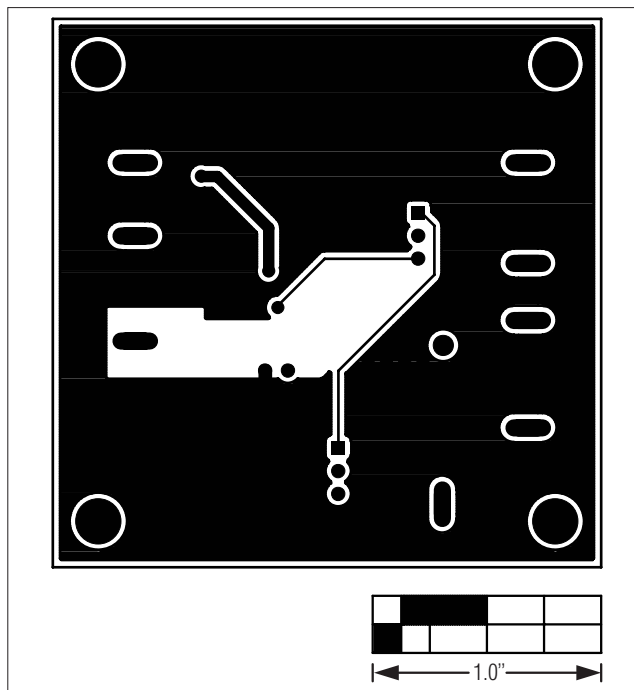

Figure 4. MAX9636 EV Kit PCB Layout—Solder Side

MAX9636 Evaluation Kit

Evaluates: MAX9636

Revision History

REVISION NUMBER	REVISION DATE	DESCRIPTION	PAGES CHANGED
0	5/10	Initial release	—

Maxim cannot assume responsibility for use of any circuitry other than circuitry entirely embodied in a Maxim product. No circuit patent licenses are implied. Maxim reserves the right to change the circuitry and specifications without notice at any time.

6 **Maxim Integrated Products, 120 San Gabriel Drive, Sunnyvale, CA 94086 408-737-7600**

© 2010 Maxim Integrated Products

Maxim is a registered trademark of Maxim Integrated Products, Inc.