

# Approval Sheet

## (產品承認書)

產品名稱 (Product)	<u>BLE AT Command Module</u> <u>in <b>Master + Slave</b> / <b>Central + Peripheral</b> role</u>
解決方案 (Solution)	<u>Nordic nRF52833 aQFN Package</u>
產品型號 (Model No.)	<u><b>MDBT50Q – UATMS</b> (u.FL Connector)</u>
韌體版本 (FW Rev.)	<u>1.1</u>

### **DEFAULT ROLE IS “PERIPHERAL / SLAVE”**

*Working distance of MDBT50Q-UATMS in open space:*

- Working distance in open space:*
  - 125K bps: over 750 meters
  - 1M bps: over 300 meters
- Declaration ID includes all Nordic applied profiles.*
- Four selected antennas to use directly with certification approval. See [10. Antenna](#)*

# Index

<b>1. Overall Introduction .....</b>	<b>5</b>
<b>2. AT Command .....</b>	<b>6</b>
2.1. List of supported commands.....	6
2.1.1. Central.....	6
2.1.2. Peripheral.....	7
2.2. AT Command Sets.....	8
2.2.1. “Central” Commands .....	8
Central “Write” .....	8
Central “Read” .....	13
2.2.2. “Peripheral” Commands.....	15
Peripheral “Write”.....	15
Peripheral “Read” .....	18
2.2.3. Response (Default).....	19
Central.....	19
Peripheral .....	22
2.3. Default Info .....	24
2.3.1. Central.....	24
2.3.2. Peripheral .....	26
2.4. Pin Assignment.....	27
<b>3. How to Control via External MCU .....</b>	<b>29</b>
3.1. How to Send AT Commands.....	29
3.1.1. UART Mode .....	29
3.1.2. USB Mode .....	30
3.2. How to Return to Setting of Default Flash.....	31
3.3. Default Definition of Connect/ADV LED Status.....	32
3.4. How to Start Scanning.....	33
<b>4. Test Report.....</b>	<b>36</b>
4.1. Current Test.....	36
4.1.1. Peripheral .....	36
4.1.2. Central.....	37
4.2. Throughput Test.....	38

<b>5. Product Dimension .....</b>	<b>49</b>
5.1. PCB Dimensions & Pin Indication.....	49
5.2. Recommended Layout of Solder Pad .....	50
5.3. RF Layout Suggestion (aka Keep-Out Area) .....	52
5.4. Footprint & Design Guide .....	53
<b>6. Main Chip Solution.....</b>	<b>54</b>
<b>7. Shipment Packaging Information .....</b>	<b>55</b>
7.1. Marking on Metal Shield .....	56
7.2. Packaging Info.....	57
7.3. Order Code.....	59
<b>8. Specification .....</b>	<b>60</b>
8.1. Absolute Maximum Ratings .....	60
8.2. Operation Conditions .....	61
8.3. Electrical Specifications .....	61
<b>9. Block Diagram .....</b>	<b>68</b>
<b>10. Antenna.....</b>	<b>69</b>
<b>11. Reference Circuit.....</b>	<b>70</b>
11.1. UART Mode .....	70
UART Mode 1 .....	70
UART Mode 2 .....	71
11.2. USB Mode .....	72
USB Mode 1 .....	72
USB Mode 2 .....	73
USB Mode 3 .....	74
<b>12. Certification .....</b>	<b>75</b>
12.1. Declaration ID .....	75
12.2. FCC Certificate (USA) .....	77
12.3. TELEC Certificate (Japan).....	78
12.4. NCC Certificate (Taiwan) .....	80
12.5. CE (EU) & RCM (Australia & New Zealand) Test Report.....	81
12.6. IC Certificate (Canada).....	84
12.7. SRRC Certificate (China).....	85
12.8. KC Certificate (South Korea) .....	86
12.9. RoHS & REACH Report .....	87
12.10. End-Product Label.....	87

**13. Notes and Cautions..... 89**

**14. Basic Facts for nRF52 Family ..... 90**

**15. Useful Links ..... 91**

**History of Firmware Revision ..... 92**

**Full List of Raytac’s BLE Modules ..... 93**

**Release Note ..... 97**

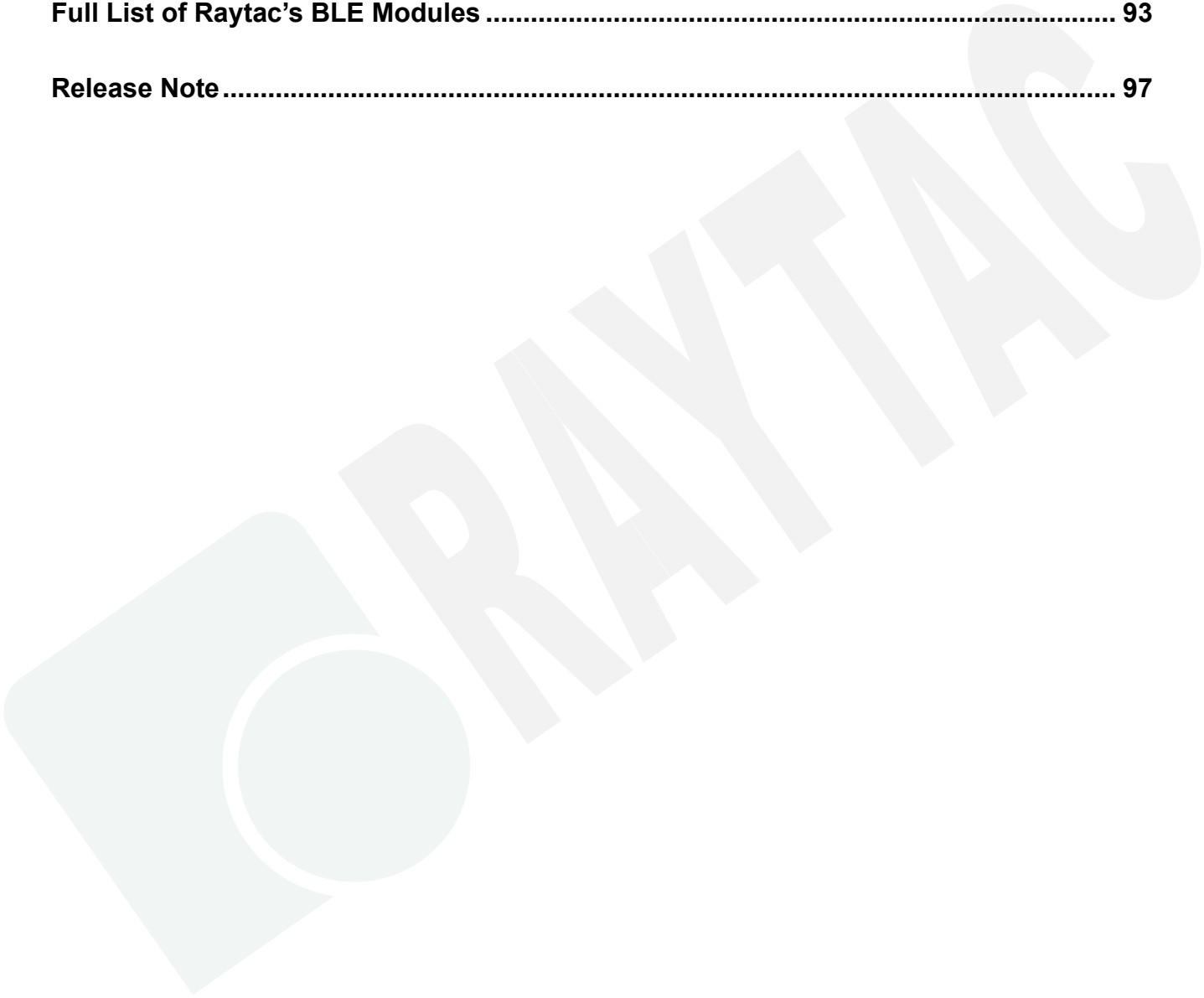

# 1. Overall Introduction

Raytac's MDBT50Q-UATMS is a BT 5.2 stack (Bluetooth low energy or BLE) module designed based on **Nordic nRF52833 SoC solution**, which incorporates: **USB/UART** interface in only **central or peripheral** role for data bridge in compact size **(L) 15.5 x (W) 10.5 x (H) 2.05 mm**.



## 2. AT Command

### 2.1. List of supported commands

#### 2.1.1. Central

- Hardware selecting of UART or USB interface
- Enable/disable interface of UART hardware for saving power
- Setting of device role as Central or Peripheral
- Setting of scanned device name
- Setting of scanned base UUID / service UUID / TX character / RX character
- Setting of scanned RSSI threshold
- Select data rate of 1 Mbps, 2 Mbps or 125 Kbps on-air
- Select output power in 6 levels.
- Select connection interval mode
- Select UART baud rates / auto baud rates under USB mode
- Select LDO or DC-to-DC power mode
- Select external or internal RC 32.768KHz oscillator
- System reset of software or hardware
- Recover-to-default setting with hardware and software method
- Set scanning/ idle time
- Start or stop scanning
- Set LED pattern indicating scanning, idle or connecting status
- Enable/disable UART flow control
- Power-down mode for power saving and GPIO wake-up
- Support DLE / maximum MTU 247 bytes / data payload up to maximum 244 bytes
- Print out scan list including RSSI, MAC address and device name
- Support direct connection to the device with specific MAC address
- Scan beacon company ID/UUID (support extended advertising beacon)
- Enable/Disable beacon information printed out through USB/UART interface (support extended advertising beacon)

## 2.1.2. Peripheral

- Hardware selecting of UART or USB interface
- Enable/disable interface of UART hardware for saving power
- Setting of device role as Central or Peripheral
- Setting of advertising device name
- Setting of base UUID / service UUID / TX character / RX character
- Select data rate of 1 Mbps, 2 Mbps or 125 Kbps on-air
- Select output power in 6 levels.
- Select connection interval mode
- Select UART baud rates / USB mode auto baud rates
- Select LDO or DC-to-DC power mode
- Select external or internal RC 32.768KHz oscillator
- System reset of software or hardware
- Recover-to-default setting with hardware and software method
- Set advertising time
- Setting of advertising interval
- Start or stop advertising
- Set LED pattern indicating advertising or connecting status
- Enable/disable UART flow control
- Power-down mode for power saving and GPIO wake-up
- Set serial number and retrieve
- Set or retrieve MAC Address
- Retrieve ADC value for battery detection, delivering the information through battery service
- Support DLE / maximum MTU 247 bytes / data payload up to maximum 244 bytes

## 2.2. AT Command Sets

### 2.2.1. “Central” Commands

#### ● Central “Write”

No.	Command	Description
(1)	<b>AT+CENTRAL</b>	Set device role as Central
(2)	<b>AT+PERIPHERAL</b>	Set device role as Peripheral
(3)	<b>AT+NAME</b>	Set device name, Max. length of 20 characters e.g. AT+NAME123 (device name 123, 3 characters)
(4)	<b>AT+BASEUUID</b> xxxxxxxxxxxxxxxxxxxx xxxxxxxxxxxxxxxxxxxx	Set base UUID for NUS ( <b>Hex</b> ), e.g. 9ECADC240EE5A9E093F3A3B5 <b>0000</b> 406E 13 <sup>th</sup> & 14 <sup>th</sup> byte is reserved for service / TX character / RX character UUID, always be <b>0000</b> . <b>Warning: The following is SIG standard base UUID</b> <b>“FB 34 9B 5F 80 00 00 80 00 10 00 00 XX XX 00 00”.</b> <b>It is prohibited to use. If used, it will cause the module</b> <b>to malfunction.</b> No matter what you put on 13 <sup>th</sup> & 14 <sup>th</sup> byte, it will lead to the same result.
(5)	<b>AT+SERVICEUUIDuuuuu</b>	Set service UUID for NUS ( <b>Hex</b> ), e.g. 0x0001
(6)	<b>AT+TXCHARACTERUUIDuuuuu</b>	Set TX character UUID for NUS ( <b>Hex</b> ), e.g. 0x0003
(7)	<b>AT+RXCHARACTERUUIDuuuuu</b>	Set RX character UUID for NUS ( <b>Hex</b> ), e.g. 0x0002
(8)	<b>AT+RSSITHRESHOLDnnn</b>	Set RSSI threshold for scanning all devices ( <b>Ascii</b> ), e.g. -90 (min.); -20 (Max.)
(9)	<b>AT+PHYMODE1MBPS</b>	Set PHY mode at 1Mbps
(10)	<b>AT+PHYMODE2MBPS</b>	Set PHY mode at 2Mbps
(11)	<b>AT+PHYMODE125KBPS</b>	Set PHY mode at 125Kbps
(12)	<b>AT+TXPOWER8DBM</b>	Set RF TX power at + 8dBm
(13)	<b>AT+TXPOWER4DBM</b>	Set RF TX power at + 4dBm
(14)	<b>AT+TXPOWER0DBM</b>	Set RF TX power at 0dBm



No.	Command	Description
(15)	AT+TXPOWER-4DBM	Set RF TX power at - 4dBm
(16)	AT+TXPOWER-8DBM	Set RF TX power to - 8dBm
(17)	AT+TXPOWER-20DBM	Set RF TX power at - 20dBm
(18)	AT+CONNECTINTERVALMODE0	Set connection interval mode for Peripheral 20ms/40ms usage (min. 20ms / Max. 40ms),
(19)	AT+CONNECTINTERVALMODE1	Set connection interval mode for Peripheral 8ms/8ms usage (min. 8ms / Max. 8ms)
(20)	AT+CONNECTINTERVALMODE2	Set connection interval mode for Peripheral usage (programmable: min. / Max. range is 8 ms ~ 1,000 ms)
(21)	AT+CONNECTINTERVALTIME $nnnnffff$	Set the range of connection interval for Mode 2, e.g. $nnnn$ = min. time / 0x0008 (Min. 8ms) $ffff$ = Max. time / 0x03E8 (Max. 1,000ms)
(22)	AT+BAUDRATE9600	Set UART baud rate at 9600 bps,n,8,1
(23)	AT+BAUDRATE19200	Set UART baud rate at 19200 bps,n,8,1
(24)	AT+BAUDRATE38400	Set UART baud rate at 38400 bps,n,8,1
(25)	AT+BAUDRATE57600	Set UART baud rate at 57600 bps,n,8,1
(26)	AT+BAUDRATE115200	Set UART baud rate at 115200 bps,n,8,1
(27)	AT+BAUDRATE230400	Set UART baud rate at 230400 bps,n,8,1
(28)	AT+BAUDRATE460800	Set UART baud rate at 460800 bps,n,8,1
(29)	AT+BAUDRATE921600	Set UART baud rate at 921600 bps,n,8,1
(30)	AT+DCDCDIS	Disable DC to DC converter (LDO mode)
(31)	AT+DCDCEN	Enable DC to DC converter (DC-to-DC mode)
(32)	AT+XTALINTERNAL	Use internal RC 32.768 KHZ oscillator
(33)	AT+XTALEXTERNAL	Use external crystal 32.768 KHZ oscillator
(34)	AT+RESET	Set to reset system
(35)	AT+SCANOLDTIME $tttt$	Set time of scanning of paired device ( <b>Hex</b> ) e.g. 0x001E (min. 30secs), 0x0258 (Max. 600secs) 0x0000 (forever)
(36)	AT+SCANNEWTIME $tttt$	Set time of scanning <b>ALL</b> devices ( <b>Hex</b> ) e.g. 0x001E (min. 30secs), 0x0258 (Max. 600secs) 0x0000 (forever)

No.	Command	Description
(37)	AT+IDLETIMEtttt	Set idle time ( <b>Hex</b> ) e.g. 0x001E (min. 30secs), 0x0258 (Max. 600secs) 0x0000 (forever)
(38)	AT+SCANOLDSTART	Set to start scanning paired device
(39)	AT+SCANNEWSTART	Set to start scanning <b>ALL</b> devices
(40)	AT+SCANSTOP	Set to stop scanning
(41)	AT+DISCONNECT	Terminate the connection
(42)	AT+IDLEPATTERNnnnnnffff	Set LED idle pattern ( <b>Hex</b> ), where n = time when LED on, f = time when LED off e.g. 0x0064 (min. 100ms) 0x1388 (Max. 5,000ms) 0x00000000 (off) 0xFFFFFFFF (on)
(43)	AT+CONNECTPATTERNnnnnnffff	Set LED connecting pattern ( <b>Hex</b> ), where n = time when LED on, f = time when LED off e.g. 0x0064 (min. 100ms) 0x1388 (Max. 5,000ms) 0x00000000 (off) 0xFFFFFFFF (on)
(44)	AT+SCANOLDPATTERNnnnnnffff	Set LED pattern for scanning paired device ( <b>Hex</b> ), where n = time when LED on, f = time when LED off e.g. 0x0064 (min. 100ms) 0x1388 (Max. 5,000ms) 0x00000000 (off) 0xFFFFFFFF (on)
(45)	AT+SCANNEWPATTERNnnnnnffff	Set LED pattern for scanning all device ( <b>Hex</b> ), where n = time when LED on, f = time when LED off e.g. 0x0064 (min. 100ms) 0x1388 (Max. 5,000ms) 0x00000000 (off) 0xFFFFFFFF (on)

No.	Command	Description
(46)	AT+FLOWCONTROLDIS	Disable UART flow control
(47)	AT+FLOWCONTROLEN	Enable UART flow control
(48)	AT+CONNECTINDICATORLOW	Set logic low output when connecting BT
(49)	AT+CONNECTINDICATORHIGH	Set logic high output when connecting BT
(50)	AT+WAKEUPLow	Set logic low at wake-up when in deep sleep
(51)	AT+WAKEUPHIGH	Set logic high at wake-up when in deep sleep
(52)	AT+SLEEP	Set to get into deep sleep mode
(53)	AT+SERIALNOnnnnnnnn	Set serial number e.g. AB000001, fixed 8-character length
(54)	AT+RESPONSEDIS	Disable response when sending "write" command
(55)	AT+RESPONSEEN	Enable response when sending "write" command
(56)	AT+DEFAULT	Back to default

(57) **AT+SCANLIST**

Set to output the list of all devices which meet the setting of **base UUID**. Output information in sequence includes:  
 (1) RSSI (2) MAC address (3) device name  
 e.g. -40, AABBCCDDEEFF, Raytac AT-UART (**Ascii**)  
 stands for  
 (1) RSSI: -40dBm  
 (2) MAC address: AABBCCDDEEFF  
 (3) device name: Raytac AT-UART

**Note:** Use "AT+SCANSTOP" to stop scanning  
 (see command (40)).

(58) **AT+SCANNEWMACnnnnnnnnnn**

Set to directly connect to the device with specific MAC address, where nnnnnnnnnnn is 12 bytes high byte to low byte **Ascii** code MAC address.  
 e.g. AT+CONNECTMACAABBCCDDEEFF (**Ascii**)

**Note:** This command is like "AT+SCANNEWSTART" command, but only scans the device with **specified** MAC address. Setting of scanning time is the same as "AT+SCANNEWTIMEttt" command.

No.	Command	Description
(59)	AT+COMPANYIDdddd	Set company ID for beacon ( <b>Hex</b> ), e.g. 0x004C (for Apple ID)
(60)	AT+BEACONUUI xxxxxxxxxxxxxxxxxxxx xxxxxxxxxxxxxxxxxxxx	Set UUID for beacon ( <b>Hex</b> ), e.g. 0112233445566778899AABBCCDDEEFF0
(61)	AT+BEACONINFOEN	Enable scanning beacon data <b>When AT+BEACONINFOEN is set, the device become a BEACON SCANNER only. If you want to exchange data, please set "AT+BEACONINFODIS".</b>
(62)	AT+BEACONINFODIS	Disable scanning beacon data
(63)	AT+COMMANDEN	Switch to command mode when BLE is connected (USB communication mode only)
(64)	AT+COMMANDDIS	Switch to transmission mode when BLE is connected (USB communication mode only)
(65)	AT+BOOTLOADER	For Raytac Test only

## ● Central “Read”

No.	Command	Description
(1)	AT?ROLE	To retrieve device role
(2)	AT?NAME	To retrieve scanned device name
(3)	AT?BASEUUID	To retrieve base UUID value <b>(Hex)</b>
(4)	AT?SERVICEUUID	To retrieve service UUID value <b>(Hex)</b>
(5)	AT?TXCHARACTERUUID	To retrieve TX character UUID value <b>(Hex)</b>
(6)	AT?RXCHARACTERUUID	To retrieve RX character UUID value <b>(Hex)</b>
(7)	AT?RSSITHRESHOLD	To retrieve scanning new RSSI threshold value <b>(Ascii)</b>
(8)	AT?CONNECTRSSI	To retrieve RSSI value when in BLE connection <b>(Ascii)</b>
(9)	AT?PHYMODE	To retrieve status of PHY mode
(10)	AT?TXPOWER	To retrieve RF TX power
(11)	AT?CONNECTINTERVALMODE	To retrieve status of connection interval mode
(12)	AT?CONNECTINTERVALTIME	To retrieve value of connection interval time under Mode 2
(13)	AT?BAUDRATE	To retrieve current UART baud rate
(14)	AT?DCDC	To retrieve DC to DC converter status
(15)	AT?XTAL	To retrieve status of 32.768KHz oscillator
(16)	AT?IDLETIME	To retrieve idle time <b>(Hex)</b>
(17)	AT?SCANOLDTIME	To retrieve time of scanning paired device <b>(Hex)</b>
(18)	AT?SCANNEWTIME	To retrieve time of scanning all devices <b>(Hex)</b>
(19)	AT?IDLEPATTERN	To retrieve LED idle pattern <b>(Hex)</b>
(20)	AT?CONNECTPATTERN	To retrieve LED connecting pattern <b>(Hex)</b>
(21)	AT?SCANOLDPATTERN	To retrieve LED pattern when scanning paired device <b>(Hex)</b>
(22)	AT?SCANNEWPATTERN	To retrieve LED pattern when scanning all devices <b>(Hex)</b>
(23)	AT?FLOWCONTROL	To retrieve UART status of flow control
(24)	AT?WAKEUP	To retrieve logic of wake-up pin
(25)	AT?CONNECTINDICATOR	To retrieve logic of pin for BT-connecting indicator
(26)	AT?SERIALNO	To retrieve serial number
(27)	AT?MACADDR	To retrieve IC MAC address
(28)	AT?ADCVALUE	To retrieve 10bit ADC value

No.	Command	Description
(29)	AT?RESPONSE	To retrieve status of response
(30)	AT?VERSION	To retrieve firmware version
(31)	AT?COMPANYID	To retrieve company ID value (Hex)
(32)	AT?BEACONUUID	To retrieve beacon UUID value (Hex)
(33)	AT?BEACONINFO	To retrieve beacon information
(34)	AT?ALLPARAMETERS	To retrieve value of all parameters
(35)	AT?BLESTATUS	To retrieve status of BLE



No.	Command	Description
(17)	AT+CONNECTINTERVALMODE0	Set connection interval mode for Peripheral 20ms/40ms usage (min. 20ms / Max. 40ms),
(18)	AT+CONNECTINTERVALMODE1	Set connection interval mode for Peripheral 8ms/8ms usage (min. 8ms / Max. 8ms)
(19)	AT+CONNECTINTERVALMODE2	Set connection interval mode for Peripheral usage (programmable: min. / Max. range is 8 ms ~ 1,000 ms)
(20)	AT+CONNECTINTERVALTIME $nnnnffff$	Set the range of connection interval for Mode 2, e.g. $nnnn$ = min. time / 0x0008 (Min. 8ms) $ffff$ = Max. time / 0x03E8 (Max. 1,000ms) "min. time $\leq$ connection interval $\leq$ Max. time"
(21)	AT+BAUDRATE9600	Set UART baud rate at 9600 bps,n,8,1
(22)	AT+BAUDRATE19200	Set UART baud rate at 19200 bps,n,8,1
(23)	AT+BAUDRATE38400	Set UART baud rate at 38400 bps,n,8,1
(24)	AT+BAUDRATE57600	Set UART baud rate at 57600 bps,n,8,1
(25)	AT+BAUDRATE115200	Set UART baud rate at 115200 bps,n,8,1
(26)	AT+BAUDRATE230400	Set UART baud rate at 230400 bps,n,8,1
(27)	AT+BAUDRATE460800	Set UART baud rate at 460800 bps,n,8,1
(28)	AT+BAUDRATE921600	Set UART baud rate at 921600 bps,n,8,1
(29)	AT+DCDCDIS	Disable DC to DC converter (LDO mode)
(30)	AT+DCDCEN	Enable DC to DC converter (DC-to-DC mode)
(31)	AT+XTALINTERNAL	Use internal RC 32.768 KHZ oscillator
(32)	AT+XTALEXTERNAL	Use external crystal 32.768 KHZ oscillator
(33)	AT+RESET	Set to reset system
(34)	AT+ADVTIME $tttt$	Set advertising time ( <b>Hex</b> ) e.g. 0x001E(min. 30secs) 0x0258(Max. 600secs) 0x0000(never)
(35)	AT+ADVINTERVALTIME $nnnn$	Set advertising interval ( <b>Hex</b> ), in units of 0.625 ms. e.g. 0x0040(min. 40ms) 0x1900(Max. 4,000ms)
(36)	AT+ADVSTART	Set to start advertising
(37)	AT+ADVSTOP	Set to stop advertising



No.	Command	Description
(38)	<b>AT+DISCONNECT</b>	Terminate the connection
(39)	<b>AT+ADVPATTERNNnnnnffff</b>	Set LED advertising pattern ( <b>Hex</b> ), where N = time when LED on, f = time when LED off e.g. 0x0064 (min. 100ms); 0x1388 (Max. 5,000ms), 0x00000000 (off) 0xFFFFFFFF (on)
(40)	<b>AT+CONNECTPATTERNNnnnnffff</b>	Set LED connecting pattern ( <b>Hex</b> ), where n = time when LED on, f = time when LED off e.g. 0x0064 (min. 100ms) 0x1388 (Max. 5,000ms) 0x00000000 (off) 0xFFFFFFFF (on)
(41)	<b>AT+FLOWCONTROLDIS</b>	Disable UART flow control
(42)	<b>AT+FLOWCONTROLEN</b>	Enable UART flow control
(43)	<b>AT+CONNECTINDICATORLOW</b>	Set logic low output when connecting BT
(44)	<b>AT+CONNECTINDICATORHIGH</b>	Set logic high output when connecting BT
(45)	<b>AT+WAKEUPLOW</b>	Set logic low at wake-up when in deep sleep
(46)	<b>AT+WAKEUPHIGH</b>	Set logic high at wake-up when in deep sleep
(47)	<b>AT+SLEEP</b>	Set to get into deep sleep mode
(48)	<b>AT+SERIALNONnnnnnnnn</b>	Set serial number e.g. AB000001, fixed 8-character length
(49)	<b>AT+MACADDRnnnnnnnnnnnn</b>	Set IC MAC address, where n is <b>Hex</b> . Written order is from MSB byte to LSB byte.
(50)	<b>AT+RESPONSEDIS</b>	Disable response when sending "write" command
(51)	<b>AT+RESPONSEEN</b>	Enable response when sending "write" command
(52)	<b>AT+DEFAULT</b>	Back to default setting
(53)	<b>AT+COMMANDEN</b>	Switch to command mode when BLE is connected (USB communication mode only)
(54)	<b>AT+COMMANDDIS</b>	Switch to transmission mode when BLE is connected (USB communication mode only)
(55)	<b>AT+BOOTLOADER</b>	For Raytac Test only

## ● Peripheral “Read”

No.	Command	Description
(1)	AT?ROLE	To retrieve device role
(2)	AT?NAME	To retrieve scanned device name
(3)	AT?BASEUUID	To retrieve base UUID value ( <b>Hex</b> )
(4)	AT?SERVICEUUID	To retrieve service UUID value ( <b>Hex</b> )
(5)	AT?TXCHARACTERUUID	To retrieve TX character UUID value ( <b>Hex</b> )
(6)	AT?RXCHARACTERUUID	To retrieve RX character UUID value ( <b>Hex</b> )
(7)	AT?PHYMODE	To retrieve status of PHY mode
(8)	AT?TXPOWER	To retrieve RF TX power
(9)	AT?CONNECTINTERVALMODE	To retrieve status of connection interval mode
(10)	AT?CONNECTINTERVALTIME	To retrieve value of connection interval time under Mode 2
(11)	AT?BAUDRATE	To retrieve current UART baud rate
(12)	AT?DCDC	To retrieve DC to DC converter status
(13)	AT?XTAL	To retrieve status of 32.768 KHZ oscillator
(14)	AT?ADVTIME	To retrieve advertising time ( <b>Hex</b> )
(15)	AT?ADVINTERVALTIME	To retrieve advertising interval time setting.
(16)	AT?ADVPATTERN	To retrieve LED advertising pattern ( <b>Hex</b> )
(17)	AT?CONNECTPATTERN	To retrieve LED connecting pattern ( <b>Hex</b> )
(18)	AT?FLOWCONTROL	To retrieve UART status of flow control
(19)	AT?WAKEUP	To retrieve logic of wake-up pin
(20)	AT?CONNECTINDICATOR	To retrieve logic of pin for BT-connecting indicator
(21)	AT?SERIALNO	To retrieve serial number
(22)	AT?MACADDR	To retrieve IC MAC address
(23)	AT?ADCVALUE	To retrieve 10bit ADC value
(24)	AT?CONNECTRSSI	To retrieve RSSI value when in BLE connection ( <b>Ascii</b> )
(25)	AT?RESPONSE	To retrieve status of response
(26)	AT?VERSION	To retrieve firmware version
(27)	AT?ALLPARAMETERS	To retrieve value of all parameters
(28)	AT?BLESTATUS	To retrieve status of BLE



No.	Command	Response
(16)	AT?IDLETIME	0000 (default: <b>Hex</b> , forever advertising with no timeout, tttt: 0x0000)
(17)	AT?SCANOLDTIME	0000 (default: <b>Hex</b> , forever scanning paired device with no timeout, tttt: 0x0000)
(18)	AT?SCANNEWTIME	0000 default: <b>Hex</b> , forever scanning ALL devices with no timeout, tttt: 0x0000)
(19)	AT?IDLEPATTERN	00640f3c (default: <b>Hex</b> , 0.1sec on / 3.9sec off, nnnn: 0x0064, ffff: 0x0f3c)
(20)	AT?CONNECTPATTERN	00c80708 (default: <b>Hex</b> , 0.2sec on / 1.8sec off, nnnn: 0x00c8, ffff: 0x0708)
(21)	AT?SCANOLDPATTERN	03e803e8 (default: <b>Hex</b> , 1sec on / 1sec off, nnnn: 0x03e8, ffff: 0x03e8)
(22)	AT?SCANNEWPATTERN	00640064 (default: <b>Hex</b> , 0.1sec on / 0.1sec off, nnnn: 0x0064, ffff: 0x0064)
(23)	AT?FLOWCONTROL	0 flowcontrol dis (default) (0 = disable; 1 = enable)
(24)	AT?WAKEUP	0 wakeup low (default) (0 = low active; 1 = high active)
(25)	AT?CONNECTINDICATOR	0 connect indicator low (default) (0 = output low; 1 = output high)
(26)	AT?SERIALNO	Display " no data! " string (default)
(27)	AT?MACADDR	e.g. D352BDE1E414
(28)	AT?ADCVALUE	Value varies from input voltage
(29)	AT?RESPONSE	1 response en (default) (0 = disable response; 1 = enable response)
(30)	AT?VERSION	e.g. version: 1.1
(31)	AT?COMPANYID	0059 (default: <b>Hex</b> , dddd: 0x0059)

No.	Command	Response
(32)	AT?BEACONUUID	0112233445566778899AABBCCDDEEFF0 (default: <b>Hex</b> , <code>xx</code> : 0x0112233445566778899AABBCCDDEEFF0)
(33)	AT?BEACONINFO	0 beaconinfo dis (default) (0 = disable to print beacon info.; 1 = enable to print beacon info.)
(34)	AT?ALLPARAMETERS	Display value of all parameters, separated by "0x0d0x0a"
(35)	AT?BLESTATUS	0 = scan idle (default) (1 = scan old start, 2 = scan new start, 3 = scan new mac, 4 = scan list, 5 = scan beacon, 8 = BLE connected.)



No.	Command	Response
(15)	AT?ADVINTERVALTIME	0040 (default: <b>Hex</b> , 40 ms)
(16)	AT?ADVPATTERN	01F401F4 (default: <b>Hex</b> , 0.5sec on / 0.5sec off, nnnn: 0x01F4, fff: 0x01F4)
(17)	AT?CONNECTPATTERN	00c80708 (default: <b>Hex</b> , 0.2sec on / 1.8sec off, nnnn: 0x00c8, ffff: 0x0708)
(18)	AT?FLOWCONTROL	0 flowcontrol dis (default) (0 = disable; 1 = enable)
(19)	AT?WAKEUP	0 wakeup low (default) (0 = low active; 1 = high active)
(20)	AT?CONNECTINDICATOR	0 connect indicator low (default) (0 = output low; 1 = output high)
(21)	AT?SERIALNO	Display " no data! " string (default)
(22)	AT?MACADDR	e.g. D352BDE1E414
(23)	AT?ADCVALUE	Value varies from input voltage
(24)	AT?CONNECTRSSI	-30 (dBm, value varies from RSSI)
(25)	AT?RESPONSE	1 response en (default) (0 = disable response; 1 = enable response)
(26)	AT?VERSION	e.g. version: 1.1
(27)	AT?ALLPARAMETERS	Display value of all parameters, separated by "0x0d0x0a"
(28)	AT?BLESTATUS	7 = adv start (default) (6 = adv. stop, 7 = adv. start, 8 = BLE connected)

## 2.3. Default Info

### 2.3.1. Central

No.	Description	Default
(1)	Scanned device name	MDBT50Q-ATMS
(2)	Base UUID	0x9E, 0xCA, 0xDC, 0x24, 0x0E, 0xE5, 0xA9, 0xE0, 0x93, 0xF3, 0xA3, 0xB5, 0x00, 0x00, 0x40, 0x6E
(3)	Service UUID	0x0001 TX characteristic: 0x0003; RX characteristic: 0x0002
(4)	Scanning new RSSI threshold	-61 (Ascii).
(5)	PHY mode	1Mbps
(6)	RF TX power	+8dBm
(7)	Connection interval mode	Mode 0 (min. 20ms / Max. 40ms),
(8)	Baud rate	9600bps,n,8,1
(9)	Status of DC-to-DC converter	Disabled (LDO mode)
(10)	32.768Khz oscillator	Using internal RC oscillator with 1,000ms calibration time
(11)	Idle time	Forever idle with no timeout
(12)	Time of scanning paired device	Forever scanning for paired device with no timeout
(13)	Time of scanning all devices	Forever scanning for all devices with no timeout
(14)	Idle LED pattern	0.1sec on / 3.9sec off
(15)	Connecting LED pattern	0.2sec on / 1.8secs off
(16)	LED pattern for scanning paired device	1sec on / 1sec off
(17)	LED pattern for scanning all devices	0.1sec on / 0.1sec off
(18)	Status of flow control	Disabled
(19)	Logic of wake-up pin	Set logic low to wake up in deep sleep
(20)	Logic of BT connecting indicator	Output set as logic low when BT is connecting
(21)	Serial number	Display " no data! " string
(22)	ADC value	Value varies from input voltage between 0x0000 ~ 0x03FF (Hex).



No.	Description	Default
(23)	State of response	Enabled
(24)	Firmware version	1.1
(25)	Company ID	0x0059
(26)	Beacon UUID	0x01, 0x12, 0x23, 0x34, 0x45, 0x56, 0x67, 0x78, 0x89, 0x9A, 0xAB, 0xBC, 0xCD, 0xDE, 0xEF, 0xF0
(27)	Communication Interface	By hardware setting



## 2.3.2. Peripheral

No.	Description	Default
(1)	Device name	MDBT50Q-ATMS
(2)	Base UUID	0x9E, 0xCA, 0xDC, 0x24, 0x0E, 0xE5, 0xA9, 0xE0, 0x93, 0xF3, 0xA3, 0xB5, 0x00, 0x00, 0x40, 0x6E
(3)	Service UUID	0x0001 TX characteristic: 0x0003; RX characteristic: 0x0002
(4)	PHY mode	1Mbps
(5)	RF TX power	+8dBm
(6)	Connection interval mode	Mode 0(min. 20ms / Max. 40ms)
(7)	Baud rate	9600bps,n,8,1
(8)	Status of DC-to-DC converter	Disable (LDO mode)
(9)	32.768KHz oscillator	Using internal RC oscillator with 1000ms calibration time
(10)	Advertising time	Forever advertising with no timeout
(11)	Advertising Interval	0x0040 Advertising interval is 40 ms
(12)	Advertising LED pattern	0.5sec on / 0.5sec off
(13)	Connecting LED pattern	0.2sec on / 1.8secs off
(14)	Status of flow control	Disable
(15)	Logic of wake-up pin	Set logic low to wake up in deep sleep
(16)	Logic of BT connecting indicator	Output set as logic low when BT is connecting
(17)	Serial number	Display “ no data! ” string
(18)	ADC value	Value varies from input voltage between 0x0000 ~ 0x03FF ( <b>Hex</b> ).
(19)	State of response	Enabled
(20)	Firmware version	1.1

## 2.4. Pin Assignment

Pin No.	Name	Pin Function	Description
(1)	<b>GND</b>	Ground	The pad must be connected to a solid ground plane
(2)	<b>GND</b>	Ground	The pad must be connected to a solid ground plane
(3)	<b>NC</b>	No function	Not connected
(4)	<b>NC</b>	No function	Not connected
(5)	<b>NC</b>	No function	Not connected
(6)	<b>USB</b>	Input	Connect to GND to enter USB mode
(7)	<b>Flash Default</b>	Input	Active-low with internal pull-high for $0.48\text{sec} \leq \text{logic low} \leq 1\text{sec}$ and return to logic high, then system will back to default.
(8)	<b>Wakeup</b>	Input / Logic	Output logic is selective about the action of wakeup from deep sleep
(9)	<b>ADC</b>	Analog input	10bit resolution ADC is always on and update every 200ms
(10)	<b>GND</b>	Ground	The pad must be connected to a solid ground plane
(11)	<b>UART PD</b>	Input	Active-high with internal pull-high to disable hardware UART interface. The default is disabled.
(12)	<b>NC</b>	No function	Not connected when using internal RC (LFXO)
	<b>XL1</b>	Analog input	Connecting to 32.768KHz crystal when using external LFXO
(13)	<b>NC</b>	No function	Not connected when using internal RC (LFXO)
	<b>XL2</b>	Analog input	Connecting to 32.768KHz crystal when using external LFXO
(14)	<b>UART RTS</b>	Output	RTS, request to send
(15)	<b>UART CTS</b>	Input	CTS, clear to send
(16)	<b>UART RX</b>	Input	UART receiver
(17)	<b>UART TX</b>	Output	UART transmitter
(18)	<b>VDD</b>	Power	Power-supply pin
(19)	<b>VDDH</b>	Power	High voltage power supply
(20)	<b>NC</b>	No function	Not connected
(21)	<b>VBUS</b>	Power	5V input for USB 3.3V regulator

Pin No.	Name	Pin Function	Description
(22)	<b>GND</b>	Ground	The pad must be connected to a solid ground plane
(23)	<b>D-</b>	Digital I/O	USB D-
(24)	<b>D+</b>	Digital I/O	USB D+
(25)	<b>Indicator</b>	Output / Logic	Output logic is selective about the action of BT connection
(26)	<b>Connect or Adver. LED</b>	Output	Setting of LED pattern is changeable when it is active-low
(27)	<b>RESET</b>	Input	Active-low to enable hardware system RESET pin
(28)	<b>NC</b>	No function	Not connected
(29)	<b>NC</b>	No function	Not connected
(30)	<b>NC</b>	No function	Not connected
(31)	<b>NC</b>	No function	Not connected
(32)	<b>SWDIO</b>	Digital I/O	Serial Wire debug I/O for debug and programming
(33)	<b>SWDCLK</b>	Digital input	Serial Wire debug clock input for debug and programming
(34)	<b>GND</b>	Ground	The pad must be connected to a solid ground plane

## 3. How to Control via External MCU

### 3.1. How to Send AT Commands

#### 3.1.1. UART Mode

- **When BT is **NOT** connected, for ALL commands**

1. Output low to **UART PD** pin to enable UART interface. Please keep it LOW during the whole time when sending AT commands.
2. Send any AT commands you want. **Please wait for at least 250 ms between sending each command.**

We recommend sending corresponding “Read” command right after the delay to know whether the writing is successful before moving on to step 3 to save your settings.

*Please prolong the delay (over 250 ms) when writing or/and reading is not successful.*

3. **Send command “ AT+RESET ” (not HW reset) to save all your settings.**
4. Output high or NC to **UART PD** pin to turn off UART interface.

- **When BT is connected, for following commands ONLY**

**Write: AT+RESET, AT+SLEEP, AT+DISCONNECT,  
AT+SCANNEWSTART**

**Read: AT?PHYMODE, AT?CONNECTRSSI, AT?ADCVALUE**

1. Output low to **flash default** pin to enable the module to receive AT commands. Please keep it LOW during the whole time when sending AT commands.
2. Send “AT+RESET” or “AT+SLEEP” or “AT+DISCONNECT” or “AT+SCANNEWSTART” “AT?PHYMODE” or “AT?CONNECTRSSI” or “AT?ADCVALUE”.
3. Output high or NC to **flash default** pin to disable the module to receive the AT commands.

### 3.1.2. USB Mode

- **When BT is **NOT** connected, for ALL commands**

1. Send any AT commands you want through COM port software. **Please wait for at least 250 ms between sending each command.**

We recommend sending corresponding “Read” command right after the delay to know whether the writing is successful before moving on to step 2 to save your settings.

*Please prolong the delay (over 250 ms) when writing or/and reading is not successful.*

2. Send command “ **AT+RESET** ” (**not HW reset**) to save all your settings through COM port software.

- **When BT is connected, for following commands ONLY**

**Write: AT+RESET, AT+SLEEP, AT+DISCONNECT,  
AT+SCANNEWSTART**

**Read: AT?PHYMODE, AT?CONNECTRSSI, AT?ADCVALUE**

1. Send “AT+COMMANDEN” to enter **command** mode when BLE is connected.
2. Send “AT+RESET” or “AT+SLEEP” or “AT+DISCONNECT” or “AT+SCANNEWSTART” or “AT?PHYMODE” or “AT?CONNECTRSSI” or “AT?ADCVALUE”.
3. Send “AT+COMMANDDIS” to go back to **data** mode when BLE is connected.

## 3.2. How to Return to Setting of Default Flash

**\* Only when BT is NOT connected \***

**\* Note that default baud rate is “9600bps,n,8,1”. For other default, please check [“2.3 Default Info”](#)**

### ● Use Hardware Method

1. Read [indicator](#) pin first to check if BT is *NOT* in connection.
2. Output a low pulse to [flash default](#) pin, then system will return to default setting.

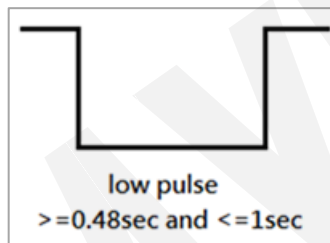



### ● Use Software method

1. Output low to [UART PD](#) pin to enable UART interface. Please keep it LOW during the whole time when sending AT commands.
2. Send command “AT+DEFAULT”, then system will return to default setting.

### 3.3. Default Definition of Connect/ADV LED Status

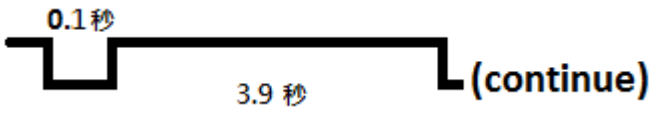
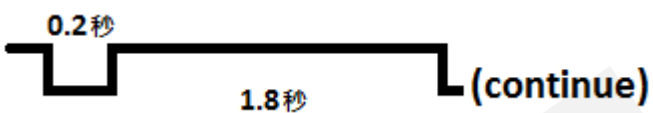
#### ● Central

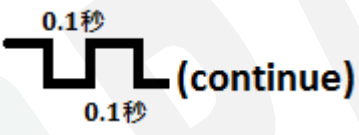
Mode	LED Status
Idle	 <p>0.1秒 3.9秒 (continue)</p> <p>0.1 sec ON / 3.9 secs OFF</p>
Connected	 <p>0.2秒 1.8秒 (continue)</p> <p>0.2 sec ON / 1.8 secs OFF</p>
Scan the paired device	 <p>1秒 1秒 (continue)</p> <p>1 sec ON / 1 sec OFF</p>
Scan all devices	 <p>0.1秒 0.1秒 (continue)</p> <p>0.1 sec ON / 0.1 sec OFF</p>

#### ● Peripheral

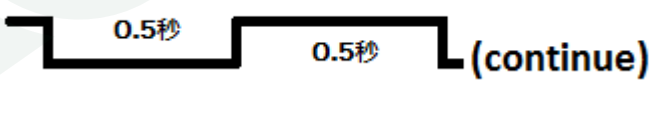
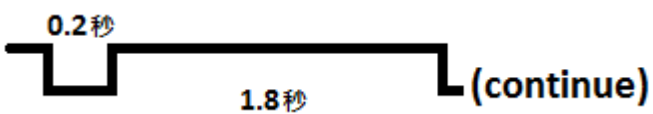
Mode	LED Status
Advertising	 <p>0.5秒 0.5秒 (continue)</p> <p>0.5 sec ON / 0.5 sec OFF</p>
Connected	 <p>0.2秒 1.8秒 (continue)</p> <p>0.2 sec ON / 1.8 secs OFF</p>



## 3.4. How to Start Scanning

This section describes how to start scanning using a physical button (hardware) or the AT Command (firmware) under various occasions. Before getting started, here are some notes applied to both methods.

- Each central device is only able to pair with 1 Peripheral.
- The device will be in idle directly when it is powered or not in BLE connection.
- A few criteria must be met in order to complete BLE connection:

	<b>Under Paired Scanning</b>	<b>Under All-Devices Scanning</b>
<b>Base UUID</b>	√	√
<b>Service UUID</b>	√	√
<b>Device name</b>	√	√
<b>RSSI Threshold</b>		√
<b>Mac Address in Paired Record</b>	√	
<b>RF Data Rate</b>	√	√

## ● Use Key/Button

### **START** Scanning Paired Device --- (a)

- Press the button for less than 2 seconds and release it to start scanning paired device.

### **START** Scanning All Devices --- (b)

- Press the button for 2 seconds or longer directly to start scanning all devices.

### **STOP** Scanning Paired / All Device(s)

- Press the button for less than 2 seconds and release it to stop scanning. The device will be back to idle and go into deep sleep after a given a timeout (no timeout in default).

<b>Device Status</b>	<b>How to Start Scanning</b>	
	Paired Device	All Devices
Idle	(a) <sup>1</sup>	(b)
BLE Connection	Not Available	(b)
Scanning Paired Device	Not Available	(b)
Scanning All Devices	(a) <sup>1</sup>	Not Available

**Remark 1:** The device stays in idle when there is no paired record.

## ● Use AT Command

### **START** Scanning Paired Device --- (a)

- Enter "AT+SCANOLDSTART" to start scanning paired device.

### **START** Scanning All Devices --- (b)

- Enter "AT+SCANNEWSTART" to start scanning all devices.

### **STOP** Scanning Paired / All Device(s)

- Enter "AT+SCANSTOP" to stop scanning. The device will be back to idle and go into deep sleep after a given timeout.

<b>Device Status</b>	<b>How to Start Scanning</b>	
	Paired Device	All Devices
Idle	(a)	(b)
BLE Connection	Not Available	(b)
Scanning Paired Device	Not Available	(b)
Scanning All Devices	(a)	Not Available

## 4. Test Report

### 4.1. Current Test

#### 4.1.1. Peripheral

##### ● UART

###### Under PHY Mode at 1 Mbps

DC/DC	Logic of UART PD pin	Advertising Current	Connected Current
Disable	High	1.271 mA	1.039 mA
	Low	1.523 mA	1.302 mA
Enable	High	0.697 mA	0.577 mA
	Low	0.946 mA	0.832 mA

##### ● USB

###### Under PHY Mode at 1 Mbps

DC/DC	Advertising Current	Connected Current
Disable	2.138 mA	1.869 mA
Enable	1.828 mA	1.703 mA

## 4.1.2. Central

### ● UART

#### Under PHY Mode at 1 Mbps

DC/DC	Logic of UART PD pin	Advertising Current	Connected Current
Disable	High	6.025 mA	1.047 mA
	Low	6.283 mA	1.309 mA
Enable	High	3.172 mA	0.577 mA
	Low	3.405 mA	0.829 mA

### ● USB

#### Under PHY Mode at 1 Mbps

DC/DC	Scanning Current	Connected Current
Disable	6.606 mA	1.861 mA
Enable	3.880 mA	1.697 mA

## 4.2. Throughput Test

Here **D.L.** means “**Data Length**” and **D.I.** means “**Data Interval**” in the table.

- MCU→ Peripheral (MDBT50Q-ATMS UART)→ Central (MDBT50Q-ATMS UART)→ PC Console
- Under **PHY mode** at **2 Mbps**

Central Connection Interval	Peripheral Connection Interval	Baud Rate	Flow Control	MCU D.L. (bytes)	MCU D.I. (ms)	Total D.L. (bytes)	Total Trans. Time (sec)	Data Rate (k-bytes/sec)
min = 20 ms Max = 40 ms	min = 20 ms Max = 40 ms	9600	X V	244	255	1049200	1095	0.93
min = 20 ms Max = 40 ms	min = 20 ms Max = 40 ms	115200	X V	244	23	1049200	98	10.45
min = 20 ms Max = 40 ms	min = 20 ms Max = 40 ms	460800	X V	244	7	1049200	30	34.15
min = 20 ms Max = 40 ms	min = 20 ms Max = 40 ms	921600	X V	244	4	1049200	16	64.03
min = Max = 8ms	min = Max = 8ms	9600	X V	244	255	1049200	1095	0.93
min = Max = 8ms	min = Max = 8ms	115200	X V	244	23	1049200	97	10.56
min = Max = 8ms	min = Max = 8ms	460800	X V	244	7	1049200	29	35.33
min = Max = 8ms	min = Max = 8ms	921600	X V	244	4	1049200	16	64.03

- Under **PHY mode** at **1 Mbps**

Central Connection Interval	Peripheral Connection Interval	Baud Rate	Flow Control	MCU D.L. (bytes)	MCU D.I. (ms)	Total D.L. (bytes)	Total Trans. Time (sec)	Data Rate (k-bytes/sec)
min = 20 ms Max = 40 ms	min = 20 ms Max = 40 ms	9600	<u>X</u> V	244	255	1049200	1095	0.93
min = 20 ms Max = 40 ms	min = 20 ms Max = 40 ms	115200	<u>X</u> V	244	23	1049200	98	10.45
min = 20 ms Max = 40 ms	min = 20 ms Max = 40 ms	460800	<u>X</u> V	244	7	1049200	30	34.15
min = 20 ms Max = 40 ms	min = 20 ms Max = 40 ms	921600	<u>X</u> V	244	4	1049200	16	64.03
min = Max = 8ms	min = Max = 8ms	9600	<u>X</u> V	244	255	1049200	1095	0.93
min = Max = 8ms	min = Max = 8ms	115200	<u>X</u> V	244	23	1049200	97	10.56
min = Max = 8ms	min = Max = 8ms	460800	<u>X</u> V	244	7	1049200	29	35.33
min = Max = 8ms	min = Max = 8ms	921600	<u>X</u> V	244	4	1049200	16	64.03

- Under **PHY mode** at **125 Kbps**

Central Connection Interval	Peripheral Connection Interval	Baud Rate	Flow Control	MCU D.L. (bytes)	MCU D.I. (ms)	Total D.L. (bytes)	Total Trans. Time (sec)	Data Rate (k-bytes/sec)
min = 20 ms Max = 40 ms	min = 20 ms Max = 40 ms	9600	$\frac{X}{V}$	244	255	1049200	1095	0.93
min = 20 ms Max = 40 ms	min = 20 ms Max = 40 ms	115200	$\frac{X}{V}$	244	39	1049200	167	6.13
min = 20 ms Max = 40 ms	min = 20 ms Max = 40 ms	460800	$\frac{X}{V}$	244	39	1049200	167	6.13
min = 20 ms Max = 40 ms	min = 20 ms Max = 40 ms	921600	$\frac{X}{V}$	244	39	1049200	167	6.13
min = Max = 8ms	min = Max = 8ms	9600	$\frac{X}{V}$	244	255	1049200	1095	0.93
min = Max = 8ms	min = Max = 8ms	115200	$\frac{X}{V}$	244	77	1049200	330	3.10
min = Max = 8ms	min = Max = 8ms	460800	$\frac{X}{V}$	244	77	1049200	330	3.10
min = Max = 8ms	min = Max = 8ms	921600	$\frac{X}{V}$	244	77	1049200	330	3.10



● MCU→ Central (MDBT50Q-ATMS UART)→ Peripheral (MDBT50Q-ATMS UART)→ PC Console

- Under **PHY mode** at **2 Mbps**

Central Connection Interval	Peripheral Connection Interval	Baud Rate	Flow Control	MCU D.L. (bytes)	MCU D.I. (ms)	Total D.L. (bytes)	Total Trans. Time (sec)	Data Rate (k-bytes/sec)
min = 20 ms Max = 40 ms	min = 20 ms Max = 40 ms	9600	X V	244	255	1049200	1095	0.93
min = 20 ms Max = 40 ms	min = 20 ms Max = 40 ms	115200	X V	244	39	1049200	167	6.13
min = 20 ms Max = 40 ms	min = 20 ms Max = 40 ms	460800	X V	244	30	1049200	129	7.94
min = 20 ms Max = 40 ms	min = 20 ms Max = 40 ms	921600	X V	244	28	1049200	119	8.61
min = Max = 8ms	min = Max = 8ms	9600	X V	244	255	1049200	1095	0.93
min = Max = 8ms	min = Max = 8ms	115200	X V	244	23	1049200	97	10.56
min = Max = 8ms	min = Max = 8ms	460800	X V	244	9	1049200	38	26.96
min = Max = 8ms	min = Max = 8ms	921600	X V	244	8	1049200	34	30.13

- Under **PHY mode** at **1 Mbps**

Central Connection Interval	Peripheral Connection Interval	Baud Rate	Flow Control	MCU D.L. (bytes)	MCU D.I. (ms)	Total D.L. (bytes)	Total Trans. Time (sec)	Data Rate (k-bytes/sec)
min = 20 ms Max = 40 ms	min = 20 ms Max = 40 ms	9600	<u>X</u> V	244	255	1049200	1095	0.93
min = 20 ms Max = 40 ms	min = 20 ms Max = 40 ms	115200	<u>X</u> V	244	39	1049200	167	6.13
min = 20 ms Max = 40 ms	min = 20 ms Max = 40 ms	460800	<u>X</u> V	244	30	1049200	128	8.00
min = 20 ms Max = 40 ms	min = 20 ms Max = 40 ms	921600	<u>X</u> V	244	28	1049200	119	8.61
min = Max = 8ms	min = Max = 8ms	9600	<u>X</u> V	244	255	1049200	1095	0.93
min = Max = 8ms	min = Max = 8ms	115200	<u>X</u> V	244	23	1049200	97	10.56
min = Max = 8ms	min = Max = 8ms	460800	<u>X</u> V	244	9	1049200	37	27.69
min = Max = 8ms	min = Max = 8ms	921600	<u>X</u> V	244	9	1049200	37	27.69

- Under **PHY mode** at **125 Kbps**

Central Connection Interval	Peripheral Connection Interval	Baud Rate	Flow Control	MCU D.L. (bytes)	MCU D.I. (ms)	Total D.L. (bytes)	Total Trans. Time (sec)	Data Rate (k-bytes/sec)
min = 20 ms Max = 40 ms	min = 20 ms Max = 40 ms	9600	<u>X</u> V	244	255	1049200	1095	0.93
min = 20 ms Max = 40 ms	min = 20 ms Max = 40 ms	115200	<u>X</u> V	244	46	1049200	197	5.20
min = 20 ms Max = 40 ms	min = 20 ms Max = 40 ms	460800	<u>X</u> V	244	46	1049200	197	5.20
min = 20 ms Max = 40 ms	min = 20 ms Max = 40 ms	921600	<u>X</u> V	244	46	1049200	197	5.20
min = Max = 8ms	min = Max = 8ms	9600	<u>X</u> V	244	255	1049200	1095	0.93
min = Max = 8ms	min = Max = 8ms	115200	<u>X</u> V	244	77	1049200	330	3.10
min = Max = 8ms	min = Max = 8ms	460800	<u>X</u> V	244	77	1049200	330	3.10
min = Max = 8ms	min = Max = 8ms	921600	<u>X</u> V	244	77	1049200	330	3.10

● MCU→ Peripheral (MDBT50Q-ATMS UART)→ Central (MDBT50Q-RX-ATM)→ PC Console

- Under **PHY mode** at **2 Mbps**

Central Connection Interval	Peripheral Connection Interval	Baud Rate	Flow Control	MCU D.L. (bytes)	MCU D.I. (ms)	Total D.L. (bytes)	Total Trans. Time (sec)	Data Rate (k-bytes/sec)
min = 20 ms Max = 40 ms	min = 20 ms Max = 40 ms	9600	<u>X</u> V	244	255	1049200	1095	0.93
min = 20 ms Max = 40 ms	min = 20 ms Max = 40 ms	115200	<u>X</u> V	244	22	1049200	93	11.01
min = 20 ms Max = 40 ms	min = 20 ms Max = 40 ms	460800	<u>X</u> V	244	6	1049200	25	40.98
min = 20 ms Max = 40 ms	min = 20 ms Max = 40 ms	921600	<u>X</u> V	244	3	1049200	12	85.38
min = Max = 8ms	min = Max = 8ms	9600	<u>X</u> V	244	255	1049200	1095	0.93
min = Max = 8ms	min = Max = 8ms	115200	<u>X</u> V	244	23	1049200	98	10.45
min = Max = 8ms	min = Max = 8ms	460800	<u>X</u> V	244	6	1049200	25	40.98
min = Max = 8ms	min = Max = 8ms	921600	<u>X</u> V	244	3	1049200	12	85.38

- Under **PHY mode** at **1 Mbps**

Central Connection Interval	Peripheral Connection Interval	Baud Rate	Flow Control	MCU D.L. (bytes)	MCU D.I. (ms)	Total D.L. (bytes)	Total Trans. Time (sec)	Data Rate (k-bytes/sec)
min = 20 ms Max = 40 ms	min = 20 ms Max = 40 ms	9600	<u>X</u> V	244	255	1049200	1095	0.93
min = 20 ms Max = 40 ms	min = 20 ms Max = 40 ms	115200	<u>X</u> V	244	22	1049200	93	11.01
min = 20 ms Max = 40 ms	min = 20 ms Max = 40 ms	460800	<u>X</u> V	244	6	1049200	25	40.98
min = 20 ms Max = 40 ms	min = 20 ms Max = 40 ms	921600	<u>X</u> V	244	3	1049200	12	85.38
min = Max = 8ms	min = Max = 8ms	9600	<u>X</u> V	244	255	1049200	1095	0.93
min = Max = 8ms	min = Max = 8ms	115200	<u>X</u> V	244	22	1049200	93	11.01
min = Max = 8ms	min = Max = 8ms	460800	<u>X</u> V	244	8	1049200	33	31.04
min = Max = 8ms	min = Max = 8ms	921600	<u>X</u> V	244	8	1049200	33	31.04

- Under **PHY mode** at **125 Kbps**

Central Connection Interval	Peripheral Connection Interval	Baud Rate	Flow Control	MCU D.L. (bytes)	MCU D.I. (ms)	Total D.L. (bytes)	Total Trans. Time (sec)	Data Rate (k-bytes/sec)
min = 20 ms Max = 40 ms	min = 20 ms Max = 40 ms	9600	$\frac{X}{V}$	244	255	1049200	1095	0.93
min = 20 ms Max = 40 ms	min = 20 ms Max = 40 ms	115200	$\frac{X}{V}$	244	39	1049200	167	6.13
min = 20 ms Max = 40 ms	min = 20 ms Max = 40 ms	460800	$\frac{X}{V}$	244	39	1049200	167	6.13
min = 20 ms Max = 40 ms	min = 20 ms Max = 40 ms	921600	$\frac{X}{V}$	244	39	1049200	167	6.13
min = Max = 8ms	min = Max = 8ms	9600	$\frac{X}{V}$	244	255	1049200	1095	0.93
min = Max = 8ms	min = Max = 8ms	115200	$\frac{X}{V}$	244	78	1049200	334	3.06
min = Max = 8ms	min = Max = 8ms	460800	$\frac{X}{V}$	244	78	1049200	334	3.06
min = Max = 8ms	min = Max = 8ms	921600	$\frac{X}{V}$	244	78	1049200	334	3.06

● MCU→ Peripheral (MDBT50Q-ATMS UART)→ Central (MDBT42Q-ATM/PATM)→ PC Console

- Under **PHY mode** at **2 Mbps**

Central Connection Interval	Peripheral Connection Interval	Baud Rate	Flow Control	MCU D.L. (bytes)	MCU D.I. (ms)	Total D.L. (bytes)	Total Trans. Time (sec)	Data Rate (k-bytes/sec)
min = 20 ms Max = 75 ms	min = 20 ms Max = 40 ms	9600	X V	244	255	1049200	1095	0.93
min = 20 ms Max = 75 ms	min = 20 ms Max = 40 ms	115200	X V	244	26	1049200	111	9.23
min = 20 ms Max = 75 ms	min = 20 ms Max = 40 ms	460800	X V	244	8	1049200	34	30.13
min = Max = 8ms	min = Max = 8ms	9600	X V	244	255	1049200	1095	0.93
min = Max = 8ms	min = Max = 8ms	115200	X V	244	26	1049200	111	9.23
min = Max = 8ms	min = Max = 8ms	921600	X V	244	8	1049200	33	31.04

- Under **PHY mode** at **1 Mbps**

Central Connection Interval	Peripheral Connection Interval	Baud Rate	Flow Control	MCU D.L. (bytes)	MCU D.I. (ms)	Total D.L. (bytes)	Total Trans. Time (sec)	Data Rate (k-bytes/sec)
min = 20 ms Max = 75 ms	min = 20 ms Max = 40 ms	9600	<u>X</u> V	244	255	1049200	1095	0.93
min = 20 ms Max = 75 ms	min = 20 ms Max = 40 ms	115200	<u>X</u> V	244	26	1049200	111	9.23
min = 20 ms Max = 75 ms	min = 20 ms Max = 40 ms	460800	<u>X</u> V	244	8	1049200	34	30.13
min = Max = 8ms	min = Max = 8ms	9600	<u>X</u> V	244	255	1049200	1095	0.93
min = Max = 8ms	min = Max = 8ms	115200	<u>X</u> V	244	26	1049200	111	9.23
min = Max = 8ms	min = Max = 8ms	921600	<u>X</u> V	244	8	1049200	33	31.04



# 5. Product Dimension

## 5.1. PCB Dimensions & Pin Indication

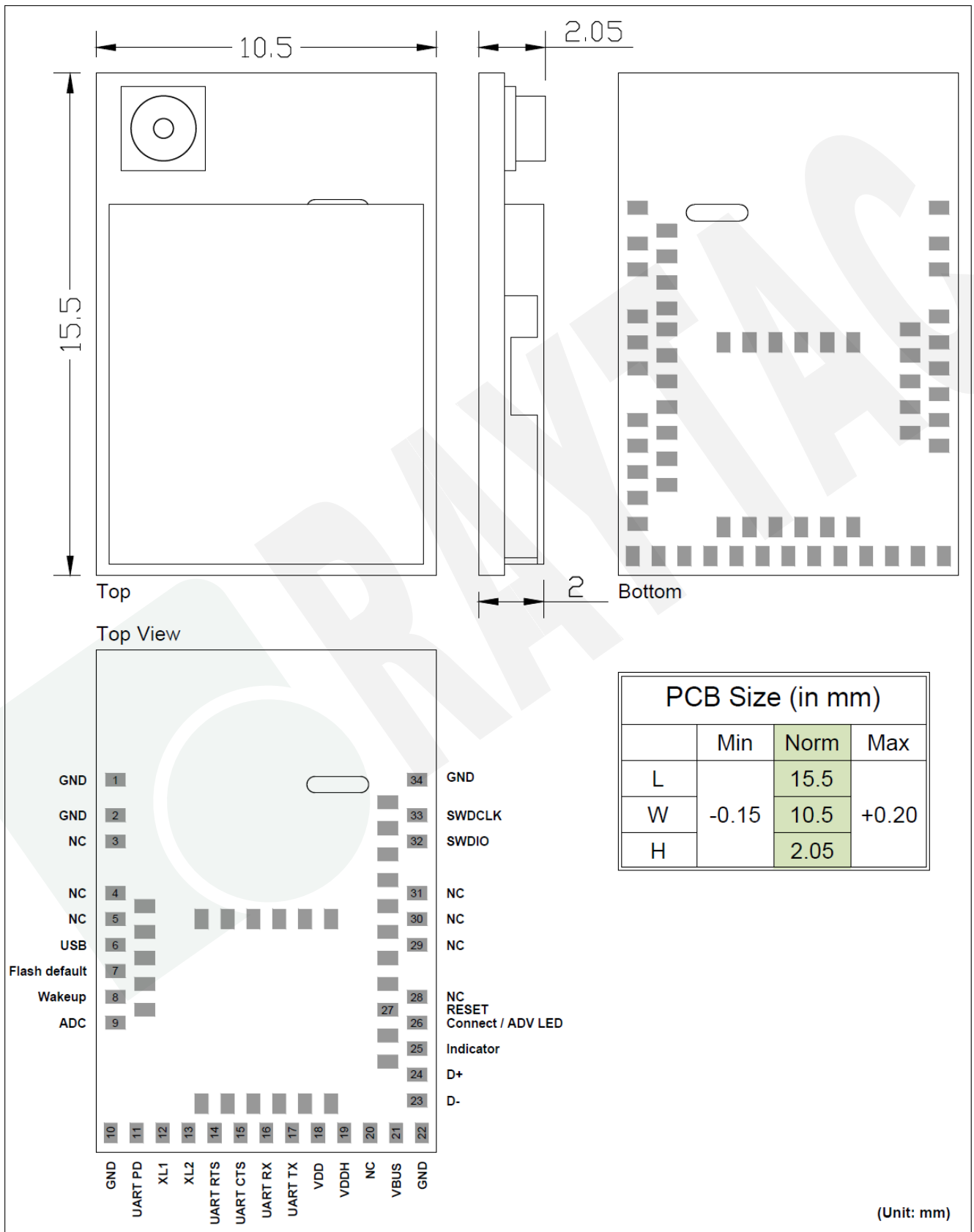

## 5.2. Recommended Layout of Solder Pad

*Graphs are all in Top View, Unit in mm.*

Top View

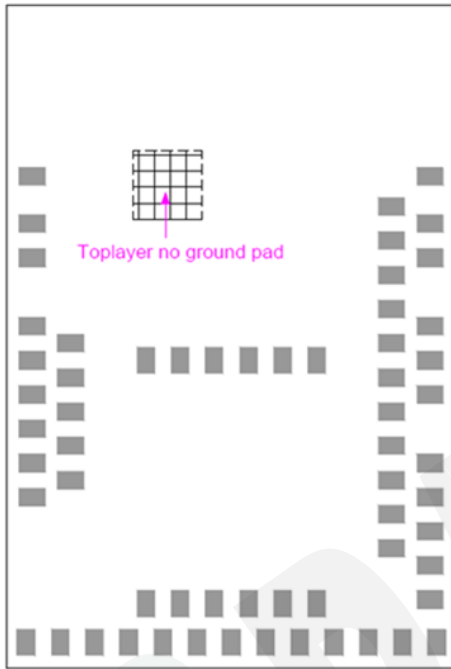

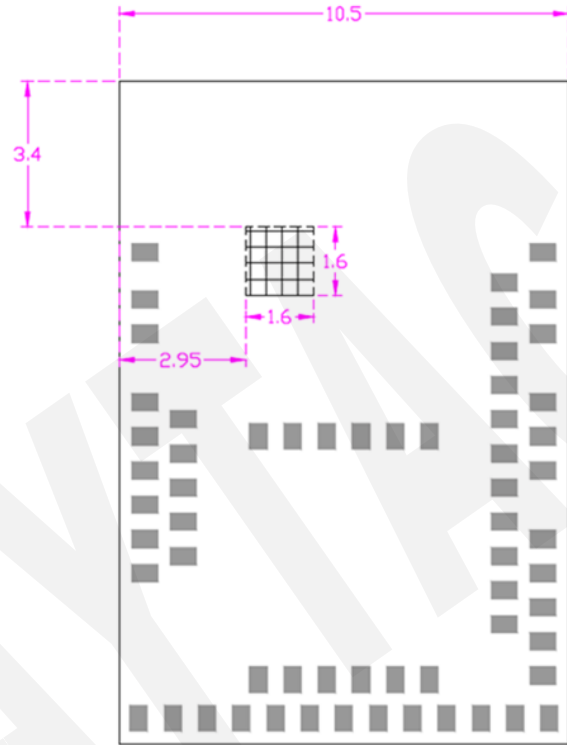

Top View (Unit: mm)

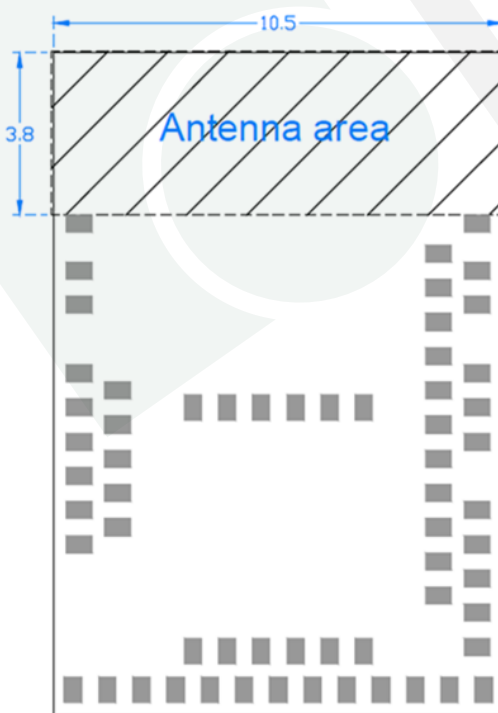

 Toplayer no ground pad

Top View (Unit: mm)



 Antenna area

Top View (Unit: mm)

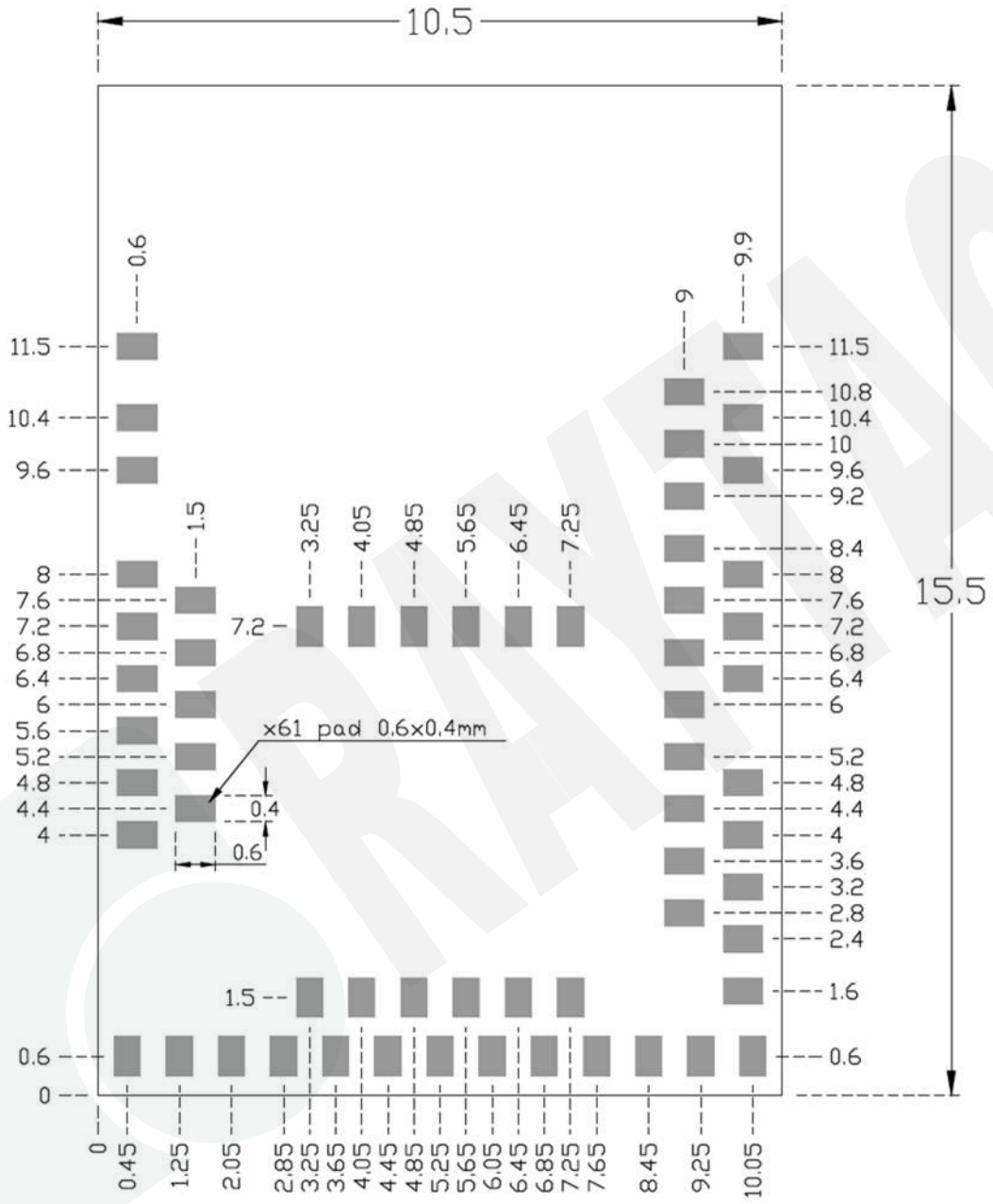

### 5.3. RF Layout Suggestion (aka Keep-Out Area)

Please follow below instruction to avoid from having Ground Pad in the area of our RF test pad. Otherwise, it may cause shortage to the module.

Welcome to send us your layout in PDF for review at [service@raytac.com](mailto:service@raytac.com) or your contact at Raytac with title "Layout reviewing – Raytac Model No. – YOUR company's name".

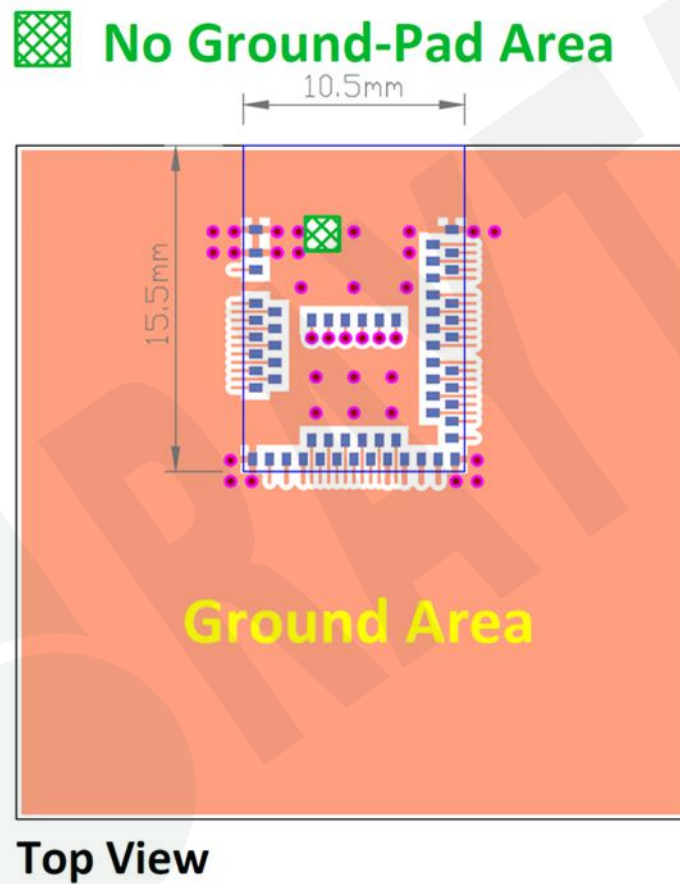

Please add via holes in GROUND area as many as possible, especially around the four corners.

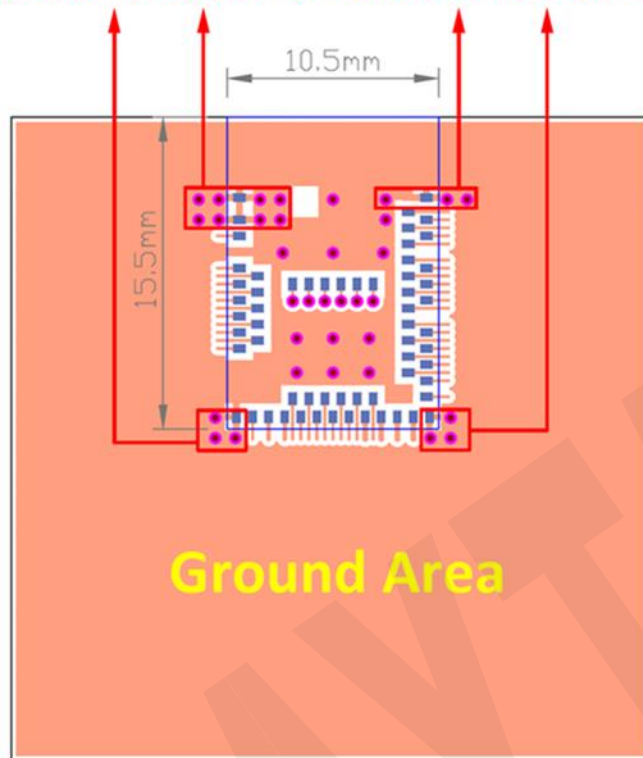

Top View



Perspective View

## 5.4. Footprint & Design Guide

Please visit "[Support](#)" page of our website to download. The package includes footprint, 2D/3D drawing, reflow graph and recommended spec for external 32.768khz.

## 6. Main Chip Solution

RF IC	Crystal Frequency
Nordic NRF52833	32MHZ

*32MHz crystal and RF (VDD) DC/DC inductor (Reg1) are already inside the module.*



## 7. Shipment Packaging Information

Model	Antenna	Photo
MDBT50Q-U512K	u.FL Connector	

- Unit Weight of Module: 0.68 g ( $\pm 0.02$  g)
- Packaging Type: Anti-static tray or Tape & Reel

	Tray	Tape & Reel
<b>MPQ (Min. Package Q'ty)</b>	88 pcs per tray	1,500 pcs per reel
<b>Carton Contents (per carton)</b>	1,760 pcs	1,500 pcs
<b>Carton Dimension (L) x (W) x (H) cm</b>	37 x 21 x 13	37 x 36 x 6
<b>Gross Weight</b>	about 2.8 kgs	about 1.9 kgs

## 7.1. Marking on Metal Shield

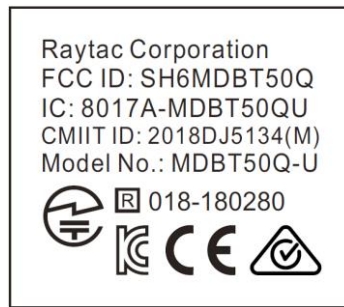



## 7.2. Packaging Info

### 7.2.1. Tray Packaging

Anti-static tray is specifically designed for mass production. It can be used directly on SMT automatic machine.

**Before July 1<sup>st</sup>, 2022**

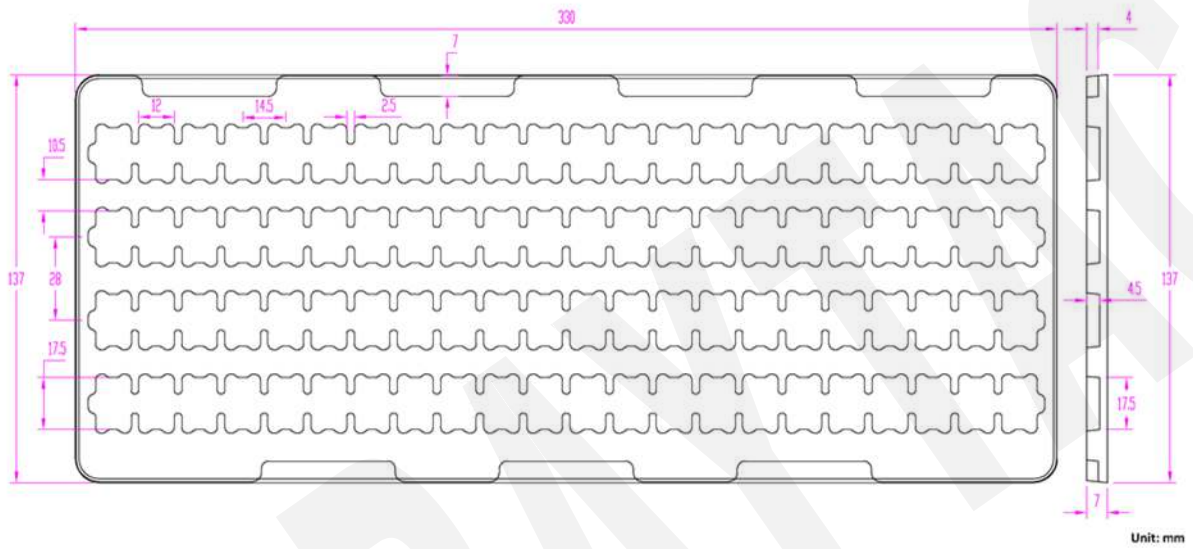

**After July 1<sup>st</sup>, 2022**

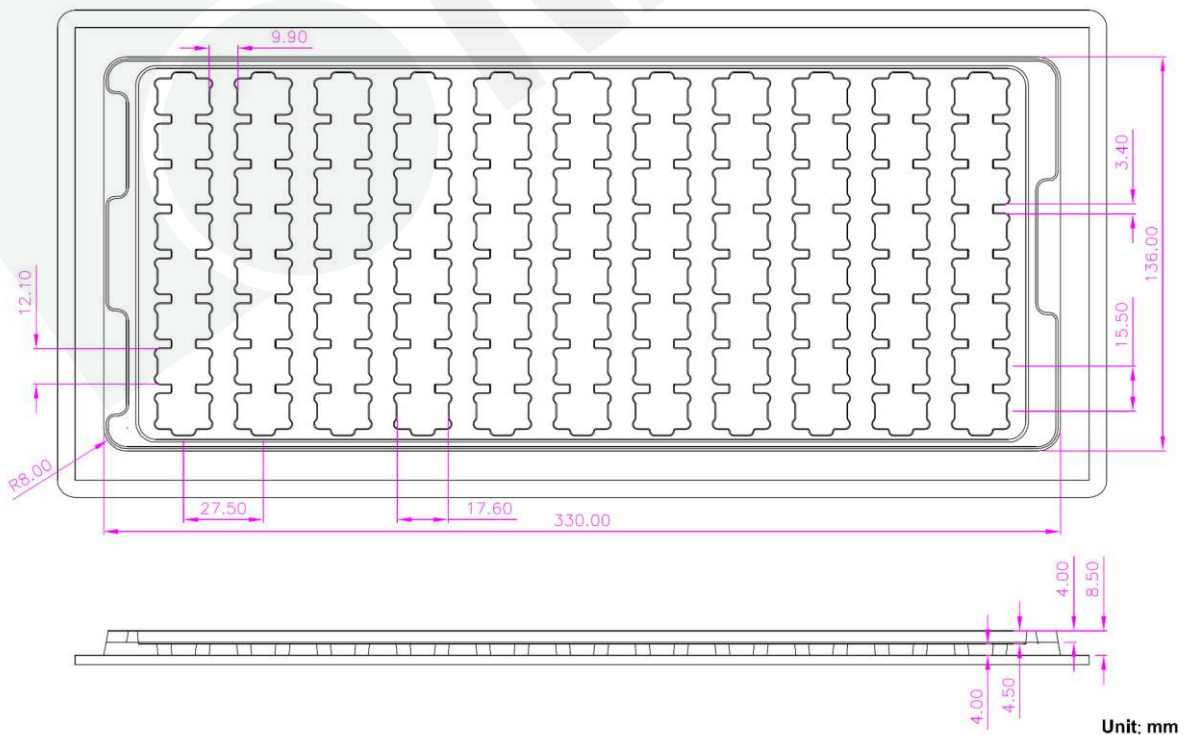

## 7.2.2. Tape & Reel Packaging

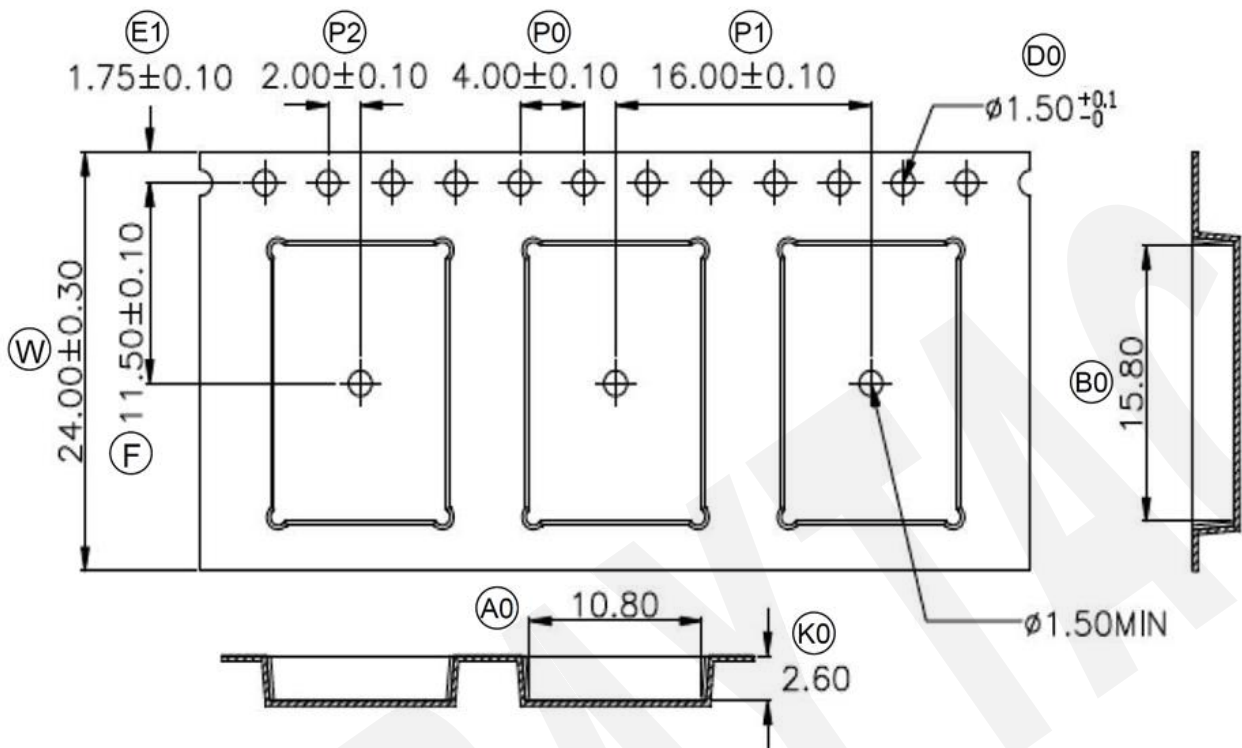

W	<b>24.00</b>	±0.30
P1	<b>16.00</b>	±0.10
E1	<b>1.75</b>	±0.10
F	<b>11.50±0.10</b>	
D0	1.50	+0.1/-0
P0	4.00	±0.10
P2	2.00±0.10	
A0	<b>10.80</b>	±0.10
B0	<b>15.80</b>	±0.10
K0	<b>2.60</b>	±0.10
T	0.30	±0.05

### 7.3. Order Code

Each model has two options of packaging. Please use following part no. when placing order to us.

<b>Model</b>	<b>Tray</b>	<b>Tape &amp; Reel</b>
MDBT50Q-UATMS	MD-240A3-046	MD-240A3-046R

*MPQ of Reel packaging is 1,500 pcs and Tray packaging is 88 pcs.*

## 8. Specification

Any technical spec shall refer to Nordic's official documents as final reference. Contents below are from "[nRF52833 Production Specification v1.5](#)", please click to download full spec.

### 8.1. Absolute Maximum Ratings

	Note	Min.	Max.	Unit
<b>Supply voltages</b>				
VDD		-0.3	+3.9	V
VDDH		-0.3	+5.8	V
VBUS		-0.3	+5.8	V
VSS			0	V
<b>I/O pin voltage</b>				
$V_{I/O}$ , VDD $\leq$ 3.6 V		-0.3	VDD + 0.3	V
$V_{I/O}$ , VDD > 3.6 V		-0.3	3.9	V
<b>NFC antenna pin current</b>				
$I_{NFC1/2}$			80	mA
<b>Environmental aQFN™ package</b>				
Storage temperature		-40	+125	°C
MSL	Moisture Sensitivity Level		2	
ESD HBM	Human Body Model		4	kV
ESD HBM Class	Human Body Model Class		3A	
ESD CDM	Charged Device Model		750	V
<b>Flash memory</b>				
Endurance		10 000		write/erase cycles
Retention at 85 °C		10		years
Retention at 105 °C	Limited to 1000 write/erase cycles	3		years
Retention at 105 °C-85 °C, execution split	Limited to 1000 write/erase cycles	6.7		years
	75% execution time at 85 °C or less			

## 8.2. Operation Conditions

Symbol	Parameter	Min.	Nom.	Max.	Units
VDD	VDD supply voltage, independent of DCDC enable	1.7	3.0	3.6	V
VDD <sub>POR</sub>	VDD supply voltage needed during power-on reset	1.75			V
VDDH	VDDH supply voltage	2.5	3.7	5.5	V
VBUS	VBUS USB supply voltage	4.35	5.0	5.5	V
t <sub>R,VDD</sub>	Supply rise time (0 V to 1.7 V)			60	ms
t <sub>R,VDDH</sub>	Supply rise time (0 V to 3.7 V)			100	ms
TA	Operating temperature	-40	25	85	°C
TA <sub>EXT</sub>	Extended operating temperature	85		105	°C
T <sub>J</sub>	Junction temperature			110	°C

Note: The on-chip power-on reset circuitry may not function properly for rise times longer than the specified maximum.

## 8.3. Electrical Specifications

### 8.3.1. General Radio Characteristics

Symbol	Description	Min.	Typ.	Max.	Units
f <sub>OP</sub>	Operating frequencies	2360		2500	MHz
f <sub>PLL,CH,SP</sub>	PLL channel spacing		1		MHz
f <sub>DELTA,1M</sub>	Frequency deviation @ 1 Mbps		±170		kHz
f <sub>DELTA,BLE,1M</sub>	Frequency deviation @ BLE 1 Mbps		±250		kHz
f <sub>DELTA,2M</sub>	Frequency deviation @ 2 Mbps		±320		kHz
f <sub>DELTA,BLE,2M</sub>	Frequency deviation @ BLE 2 Mbps		±500		kHz
f <sub>skBPS</sub>	On-the-air data rate	125		2000	kbps
f <sub>chip, IEEE 802.15.4</sub>	Chip rate in IEEE 802.15.4 mode		2000		kchips

### 8.3.2. Radio Current Consumption (Transmitter)

Symbol	Description	Min.	Typ.	Max.	Units
$I_{TX,PLUS8dBm,DCDC}$	TX only run current (DC/DC, 3 V) $P_{RF} = +8$ dBm		14.2		mA
$I_{TX,PLUS8dBm}$	TX only run current $P_{RF} = +8$ dBm		30.4		mA
$I_{TX,PLUS4dBm,DCDC}$	TX only run current (DC/DC, 3 V) $P_{RF} = +4$ dBm		9.6		mA
$I_{TX,PLUS4dBm}$	TX only run current $P_{RF} = +4$ dBm		20.7		mA
$I_{TX,0dBm,DCDC}$	TX only run current (DC/DC, 3 V) $P_{RF} = 0$ dBm		4.9		mA
$I_{TX,0dBm}$	TX only run current $P_{RF} = 0$ dBm		10.3		mA
$I_{TX,MINUS4dBm,DCDC}$	TX only run current DC/DC, 3 V $P_{RF} = -4$ dBm		3.8		mA
$I_{TX,MINUS4dBm}$	TX only run current $P_{RF} = -4$ dBm		8.0		mA
$I_{TX,MINUS8dBm,DCDC}$	TX only run current DC/DC, 3 V $P_{RF} = -8$ dBm		3.4		mA
$I_{TX,MINUS8dBm}$	TX only run current $P_{RF} = -8$ dBm		7.1		mA
$I_{TX,MINUS12dBm,DCDC}$	TX only run current DC/DC, 3 V $P_{RF} = -12$ dBm		3.1		mA
$I_{TX,MINUS12dBm}$	TX only run current $P_{RF} = -12$ dBm		6.4		mA
$I_{TX,MINUS16dBm,DCDC}$	TX only run current DC/DC, 3 V $P_{RF} = -16$ dBm		2.9		mA
$I_{TX,MINUS16dBm}$	TX only run current $P_{RF} = -16$ dBm		5.9		mA
$I_{TX,MINUS20dBm,DCDC}$	TX only run current DC/DC, 3 V $P_{RF} = -20$ dBm		2.7		mA
$I_{TX,MINUS20dBm}$	TX only run current $P_{RF} = -20$ dBm		5.5		mA
$I_{TX,MINUS40dBm,DCDC}$	TX only run current DC/DC, 3 V $P_{RF} = -40$ dBm		2.3		mA
$I_{TX,MINUS40dBm}$	TX only run current $P_{RF} = -40$ dBm		4.5		mA
$I_{START,TX,DCDC}$	TX start-up current DC/DC, 3 V, $P_{RF} = 4$ dBm		4.3		mA
$I_{START,TX}$	TX start-up current, $P_{RF} = 4$ dBm		8.9		mA

### 8.3.3. Radio Current Consumption (Receiver)

Symbol	Description	Min.	Typ.	Max.	Units
$I_{RX,1M,DCDC}$	RX only run current (DC/DC, 3 V) 1 Mbps/1 Mbps BLE		4.6		mA
$I_{RX,1M}$	RX only run current (LDO, 3 V) 1 Mbps/1 Mbps BLE		9.6		mA
$I_{RX,2M,DCDC}$	RX only run current (DC/DC, 3 V) 2 Mbps/2 Mbps BLE		5.2		mA
$I_{RX,2M}$	RX only run current (LDO, 3 V) 2 Mbps/2 Mbps BLE		10.7		mA
$I_{START,RX,1M,DCDC}$	RX start-up current (DC/DC, 3 V) 1 Mbps/1 Mbps BLE		3.4		mA
$I_{START,RX,1M}$	RX start-up current 1 Mbps/1 Mbps BLE		6.8		mA

### 8.3.4. Transmitter Specification

Symbol	Description	Min.	Typ.	Max.	Units
$P_{RF}$	Maximum output power		8		dBm
$P_{RFC}$	RF power control range		28		dB
$P_{RFCR}$	RF power accuracy			$\pm 4$	dB
$P_{RF1,1}$	1st Adjacent Channel Transmit Power 1 MHz (1 Mbps)		-25		dBc
$P_{RF2,1}$	2nd Adjacent Channel Transmit Power 2 MHz (1 Mbps)		-54		dBc
$P_{RF1,2}$	1st Adjacent Channel Transmit Power 2 MHz (2 Mbps)		-26		dBc
$P_{RF2,2}$	2nd Adjacent Channel Transmit Power 4 MHz (2 Mbps)		-54		dBc
$E_{vm}$	Error vector magnitude IEEE 802.15.4		9		%rms
$P_{harm2nd, IEEE 802.15.4}$	2nd harmonics in IEEE 802.15.4 mode		-51		dBm
$P_{harm3rd, IEEE 802.15.4}$	3rd harmonics in IEEE 802.15.4		-51		dBm

### 8.3.5. RSSI Specifications

Symbol	Description	Min.	Typ.	Max.	Units
$RSSI_{ACC}$	RSSI accuracy valid range -90 to -30 dBm		$\pm 2$		dB
$RSSI_{RESOLUTION}$	RSSI resolution		1		dB
$RSSI_{PERIOD}$	RSSI sampling time from $RSSI\_START$ task		0.25		$\mu s$
$RSSI_{SETTLE}$	RSSI settling time after signal level change		15		$\mu s$



## 8.3.6. Receiver Operation

Symbol	Description	Min.	Typ.	Max.	Units
P <sub>RX,MAX</sub>	Maximum received signal strength at < 0.1% PER		0		dBm
P <sub>SENS,IT,1M</sub>	Sensitivity, 1 Mbps nRF mode ideal transmitter <sup>17</sup>		-93		dBm
P <sub>SENS,IT,2M</sub>	Sensitivity, 2 Mbps nRF mode ideal transmitter <sup>17</sup>		-89		dBm
P <sub>SENS,IT,SP,1M,BLE</sub>	Sensitivity, 1 Mbps BLE ideal transmitter, packet length ≤ 37 bytes BER=1E-3 <sup>18</sup>		-96		dBm
P <sub>SENS,IT,LP,1M,BLE</sub>	Sensitivity, 1 Mbps BLE ideal transmitter, packet length ≥ 128 bytes BER=1E-4 <sup>19</sup>		-94		dBm
P <sub>SENS,IT,SP,2M,BLE</sub>	Sensitivity, 2 Mbps BLE ideal transmitter, packet length ≤ 37 bytes		-92		dBm
P <sub>SENS,IT,BLE LE125k</sub>	Sensitivity, 125 kbps BLE mode		-103		dBm
P <sub>SENS,IT,BLE LE500k</sub>	Sensitivity, 500 kbps BLE mode		-98		dBm
P <sub>SENS,IEEE 802.15.4</sub>	Sensitivity in IEEE 802.15.4 mode		-100		dBm

<sup>17</sup> Typical sensitivity applies when ADDR0 is used for receiver address correlation. When ADDR[1...7] are used for receiver address correlation, the typical sensitivity for this mode is degraded by 3 dB.

<sup>18</sup> As defined in the *Bluetooth Core Specification v4.0 Volume 6: Core System Package (Low Energy Controller Volume)*.

<sup>19</sup> Equivalent BER limit < 10E-04.

## 8.3.7. RX Selectivity

Symbol	Description	Min.	Typ.	Max.	Units
C/I <sub>1M,co-channel</sub>	1Mbps mode, co-channel interference		10		dB
C/I <sub>1M,-1MHz</sub>	1 Mbps mode, Adjacent (-1 MHz) interference		-5		dB
C/I <sub>1M,+1MHz</sub>	1 Mbps mode, Adjacent (+1 MHz) interference		-14		dB
C/I <sub>1M,-2MHz</sub>	1 Mbps mode, Adjacent (-2 MHz) interference		-19		dB
C/I <sub>1M,+2MHz</sub>	1 Mbps mode, Adjacent (+2 MHz) interference		-42		dB
C/I <sub>1M,-3MHz</sub>	1 Mbps mode, Adjacent (-3 MHz) interference		-37		dB
C/I <sub>1M,+3MHz</sub>	1 Mbps mode, Adjacent (+3 MHz) interference		-47		dB
C/I <sub>1M,±6MHz</sub>	1 Mbps mode, Adjacent (≥6 MHz) interference		-52		dB
C/I <sub>1MBLE,co-channel</sub>	1 Mbps BLE mode, co-channel interference		6		dB
C/I <sub>1MBLE,-1MHz</sub>	1 Mbps BLE mode, Adjacent (-1 MHz) interference		-2		dB
C/I <sub>1MBLE,+1MHz</sub>	1 Mbps BLE mode, Adjacent (+1 MHz) interference		-10		dB
C/I <sub>1MBLE,-2MHz</sub>	1 Mbps BLE mode, Adjacent (-2 MHz) interference		-23		dB
C/I <sub>1MBLE,+2MHz</sub>	1 Mbps BLE mode, Adjacent (+2 MHz) interference		-45		dB
C/I <sub>1MBLE,&gt;3MHz</sub>	1 Mbps BLE mode, Adjacent (≥3 MHz) interference		-54		dB
C/I <sub>1MBLE,image</sub>	Image frequency interference		-24		dB
C/I <sub>1MBLE,image,1MHz</sub>	Adjacent (1 MHz) interference to in-band image frequency		-37		dB



Symbol	Description	Min.	Typ.	Max.	Units
$C/I_{2M,co-channel}$	2 Mbps mode, co-channel interference		10		dB
$C/I_{2M,-2MHz}$	2 Mbps mode, Adjacent (-2 MHz) interference		-4		dB
$C/I_{2M,+2MHz}$	2 Mbps mode, Adjacent (+2 MHz) interference		-16		dB
$C/I_{2M,-4MHz}$	2 Mbps mode, Adjacent (-4 MHz) interference		-19		dB
$C/I_{2M,+4MHz}$	2 Mbps mode, Adjacent (+4 MHz) interference		-46		dB
$C/I_{2M,-6MHz}$	2 Mbps mode, Adjacent (-6 MHz) interference		-41		dB
$C/I_{2M,+6MHz}$	2 Mbps mode, Adjacent (+6 MHz) interference		-48		dB
$C/I_{2M,\geq 12MHz}$	2 Mbps mode, Adjacent ( $\geq 12$ MHz) interference		-52		dB
$C/I_{2MBLE,co-channel}$	2 Mbps BLE mode, co-channel interference		7		dB
$C/I_{2MBLE,-2MHz}$	2 Mbps BLE mode, Adjacent (-2 MHz) interference		-2		dB
$C/I_{2MBLE,+2MHz}$	2 Mbps BLE mode, Adjacent (+2 MHz) interference		-12		dB
$C/I_{2MBLE,-4MHz}$	2 Mbps BLE mode, Adjacent (-4 MHz) interference		-22		dB
$C/I_{2MBLE,+4MHz}$	2 Mbps BLE mode, Adjacent (+4 MHz) interference		-46		dB
$C/I_{2MBLE,\geq 6MHz}$	2 Mbps BLE mode, Adjacent ( $\geq 6$ MHz) interference		-52		dB
$C/I_{2MBLE,image}$	Image frequency interference		-22		dB
$C/I_{2MBLE,image, 2MHz}$	Adjacent (2 MHz) interference to in-band image frequency		-37		dB
$C/I_{125k BLE LR,co-channel}$	125 kbps BLE LR mode, co-channel interference		3		dB
$C/I_{125k BLE LR,-1MHz}$	125 kbps BLE LR mode, Adjacent (-1 MHz) interference		-9		dB
$C/I_{125k BLE LR,+1MHz}$	125 kbps BLE LR mode, Adjacent (+1 MHz) interference		-16		dB
$C/I_{125k BLE LR,-2MHz}$	125 kbps BLE LR mode, Adjacent (-2 MHz) interference		-27		dB
$C/I_{125k BLE LR,+2MHz}$	125 kbps BLE LR mode, Adjacent (+2 MHz) interference		-54		dB
$C/I_{125k BLE LR,>3MHz}$	125 kbps BLE LR mode, Adjacent ( $\geq 3$ MHz) interference		-60		dB
$C/I_{125k BLE LR,image}$	Image frequency interference		-27		dB
$C/I_{IEEE 802.15.4,-5MHz}$	IEEE 802.15.4 mode, Adjacent (-5 MHz) rejection		-33		dB
$C/I_{IEEE 802.15.4,+5MHz}$	IEEE 802.15.4 mode, Adjacent (+5 MHz) rejection		-38		dB
$C/I_{IEEE 802.15.4,\pm 10MHz}$	IEEE 802.15.4 mode, Alternate ( $\pm 10$ MHz) rejection		-49		dB

Remark: Desired signal level at PIN = -67 dBm. One interferer is used, having equal modulation as the desired signal. The input power of the interferer where the sensitivity equals BER = 0.1% is presented.

## 8.3.8. RX Intermodulation

Symbol	Description	Min.	Typ.	Max.	Units
P <sub>IMD,5TH,1M</sub>	IMD performance, 1 Mbps, 5th offset channel, packet length ≤ 37 bytes		-34		dBm
P <sub>IMD,5TH,1M,BLE</sub>	IMD performance, BLE 1 Mbps, 5th offset channel, packet length ≤ 37 bytes		-32		dBm
P <sub>IMD,5TH,2M</sub>	IMD performance, 2 Mbps, 5th offset channel, packet length ≤ 37 bytes		-33		dBm
P <sub>IMD,5TH,2M,BLE</sub>	IMD performance, BLE 2 Mbps, 5th offset channel, packet length ≤ 37 bytes		-32		dBm

Remark: Desired signal level at PIN = -64 dBm. Two interferers with equal input power are used. The interferer closest in frequency is not modulated, the other interferer is modulated equal with the desired signal. The input power of the interferers where the sensitivity equals BER = 0.1% is presented.

## 8.3.9. Radio Timing Parameters

Symbol	Description	Min.	Typ.	Max.	Units
t <sub>TXEN,BLE,1M</sub>	Time between TXEN task and READY event after channel FREQUENCY configured (1 Mbps BLE and 150 μs TIFS)	140		140	μs
t <sub>TXEN,FAST,BLE,1M</sub>	Time between TXEN task and READY event after channel FREQUENCY configured (1 Mbps BLE with fast ramp-up and 150 μs TIFS)	40		40	μs
t <sub>TXDIS,BLE,1M</sub>	When in TX, delay between DISABLE task and DISABLED event for MODE = Nrf_1Mbit and MODE = Ble_1Mbit	6		6	μs
t <sub>RXEN,BLE,1M</sub>	Time between the RXEN task and READY event after channel FREQUENCY configured (1 Mbps BLE)	140		140	μs
t <sub>RXEN,FAST,BLE,1M</sub>	Time between the RXEN task and READY event after channel FREQUENCY configured (1 Mbps BLE with fast ramp-up)	40		40	μs
t <sub>RXDIS,BLE,1M</sub>	When in RX, delay between DISABLE task and DISABLED event for MODE = Nrf_1Mbit and MODE = Ble_1Mbit	0		0	μs
t <sub>TXDIS,BLE,2M</sub>	When in TX, delay between DISABLE task and DISABLED event for MODE = Nrf_2Mbit and MODE = Ble_2Mbit	4		4	μs
t <sub>RXDIS,BLE,2M</sub>	When in RX, delay between DISABLE task and DISABLED event for MODE = Nrf_2Mbit and MODE = Ble_2Mbit	0		0	μs
t <sub>TXEN,IEEE 802.15.4</sub>	Time between TXEN task and READY event after channel FREQUENCY configured (IEEE 802.15.4)	130		130	μs
t <sub>TXEN,FAST,IEEE 802.15.4</sub>	Time between TXEN task and READY event after channel FREQUENCY configured (IEEE 802.15.4 with fast ramp-up)	40		40	μs
t <sub>TXDIS,IEEE 802.15.4</sub>	When in TX, delay between DISABLE task and DISABLED event (IEEE 802.15.4)	21		21	μs
t <sub>RXEN,IEEE 802.15.4</sub>	Time between the RXEN task and READY event after channel FREQUENCY configured (IEEE 802.15.4)	130		130	μs
t <sub>RXEN,FAST,IEEE 802.15.4</sub>	Time between the RXEN task and READY event after channel FREQUENCY configured (IEEE 802.15.4 with fast ramp-up)	40		40	μs
t <sub>RXDIS,IEEE 802.15.4</sub>	When in RX, delay between DISABLE task and DISABLED event (IEEE 802.15.4)	0.5		0.5	μs
t <sub>RX-to-TX turnaround</sub>	Maximum TX-to-RX or RX-to-TX turnaround time in IEEE 802.15.4 mode		40		μs

## 8.3.10. CPU

Symbol	Description	Min.	Typ.	Max.	Units
$W_{FLASH}$	CPU wait states, running CoreMark from flash, cache disabled			2	
$W_{FLASHCACHE}$	CPU wait states, running CoreMark from flash, cache enabled			3	
$W_{RAM}$	CPU wait states, running CoreMark from RAM			0	
$CM_{FLASH}$	CoreMark, running CoreMark from flash, cache enabled		217		CoreMark
$CM_{FLASH/MHz}$	CoreMark per MHz, running CoreMark from flash, cache enabled		3.4		CoreMark/ MHz
$CM_{FLASH/mA}$	CoreMark per mA, running CoreMark from flash, cache enabled, DCDC 3V		65.8		CoreMark/ mA

## 8.3.11. Power Management





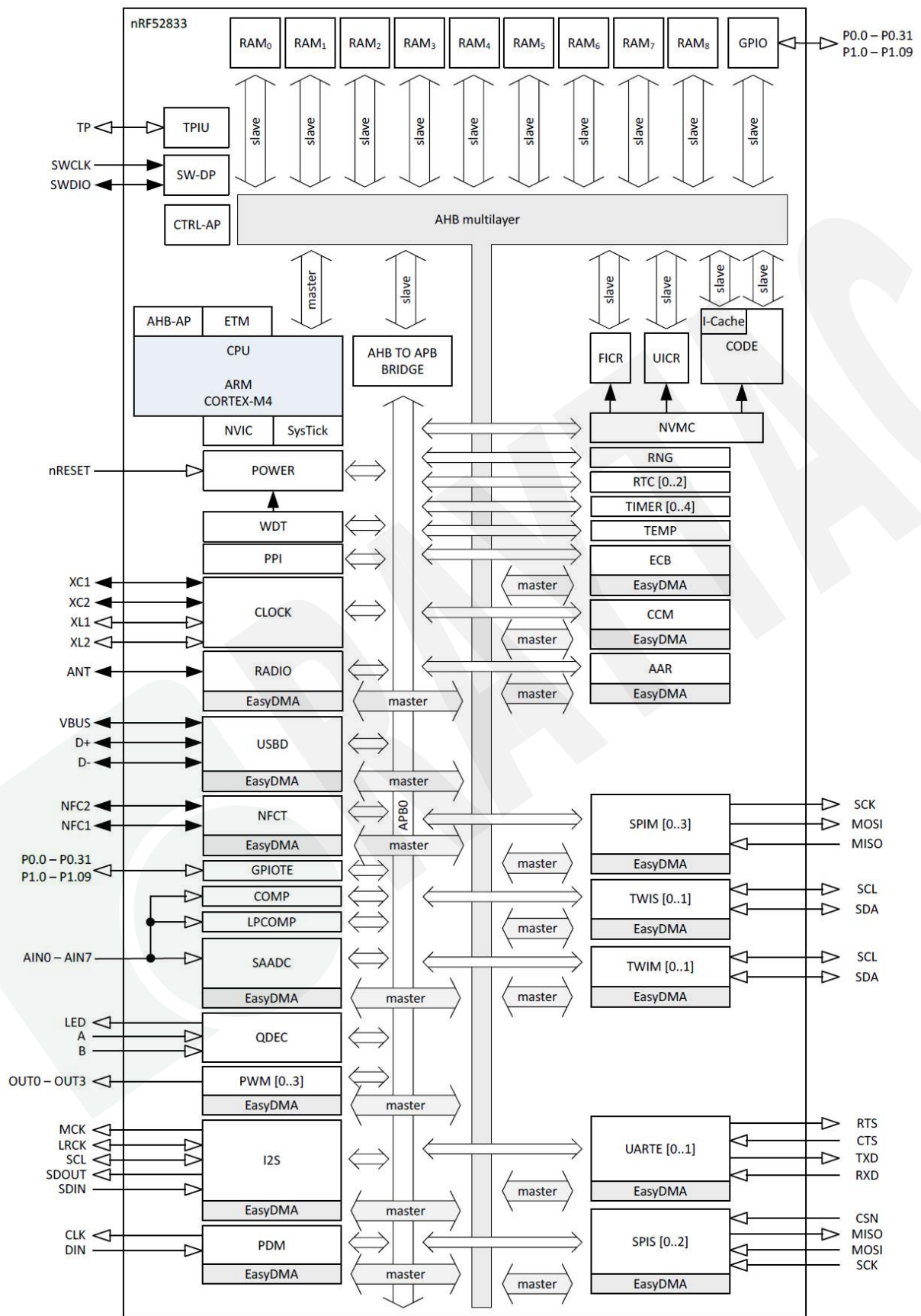



Symbol	Description	Min.	Typ.	Max.	Units
$I_{ON\_RAMOFF\_EVENT}$	System ON, no RAM retention, wake on any event		1.1		$\mu A$
$I_{ON\_RAMON\_EVENT}$	System ON, full 128 kB RAM retention, wake on any event		1.8		$\mu A$
$I_{ON\_RAMON\_POF}$	System ON, full 128 kB RAM retention, wake on any event, power-fail comparator enabled		1.9		$\mu A$
$I_{ON\_RAMON\_GPIOTE}$	System ON, full 128 kB RAM retention, wake on GPIOTE input (event mode)		7.4		$\mu A$
$I_{ON\_RAMON\_GPIOTEPORT}$	System ON, full 128 kB RAM retention, wake on GPIOTE PORT event		1.8		$\mu A$
$I_{ON\_RAMOFF\_RTC}$	System ON, no RAM retention, wake on RTC (running from LFRC clock)		1.5		$\mu A$
$I_{ON\_RAMON\_RTC}$	System ON, full 128 kB RAM retention, wake on RTC (running from LFRC clock)		2.6		$\mu A$
$I_{OFF\_RAMOFF\_RESET}$	System OFF, no RAM retention, wake on reset		0.6		$\mu A$
$I_{OFF\_RAMOFF\_LPCOMP}$	System OFF, no RAM retention, wake on LPCOMP		0.9		$\mu A$
$I_{OFF\_RAMON\_RESET}$	System OFF, full 128 kB RAM retention, wake on reset		1.3		$\mu A$
$I_{ON\_RAMOFF\_EVENT\_5V}$	System ON, no RAM retention, wake on any event, 5 V supply on VDDH, REG0 output = 3.3 V		1.3		$\mu A$
$I_{OFF\_RAMOFF\_RESET\_5V}$	System OFF, no RAM retention, wake on reset, 5 V supply on VDDH, REG0 output = 3.3 V		1.0		$\mu A$

# 9. Block Diagram



# 10. Antenna

Below chart shows a few options of external antenna which has been tested and approved to use with MDBT50Q-U. Please check [12 Certification](#) for more details.

#	Photo	Model No.	Type	Supplier	Gain	Spec	Certification
1		ANTX100 ETHAB24553	External	Yageo	≤ 2 dBi		FCC, IC, TELEC KC, NCC, CE SRRC, RCM
2		RFA-02-5 -F17H170100B	External	Aristotle	5 dBi		FCC, IC, KC NCC, SRRC
3		ANTX100 P011B24003	PCB	Yageo	2.2 dBi		FCC, IC, TELEC KC, NCC, CE SRRC, RCM
4		ANTX100 P111B24003	PCB	Yageo	3.3 dBi		FCC, IC, TELEC KC, NC, SRRC

*\* End-product may need to perform further testing when applying CE, RCM and SRRC. Others are modular approval.*

*\* Our certificate(s) might not be applicable when using antenna apart from above list.*



# 11. Reference Circuit

*Module is pre-programmed with Raytac's AT command firmware. Default is "LDO mode" and uses internal 32.768khz RC oscillator.*

## 11.1. UART Mode

- UART Mode 1

**\*\* PIN 6 (USB) is NOT connected**

**\*\* Recommend using when VDDH is less than 3.6V. Supply power from VDDH.**

**\*\* GPIO logic level follows the voltage of VDDH.**

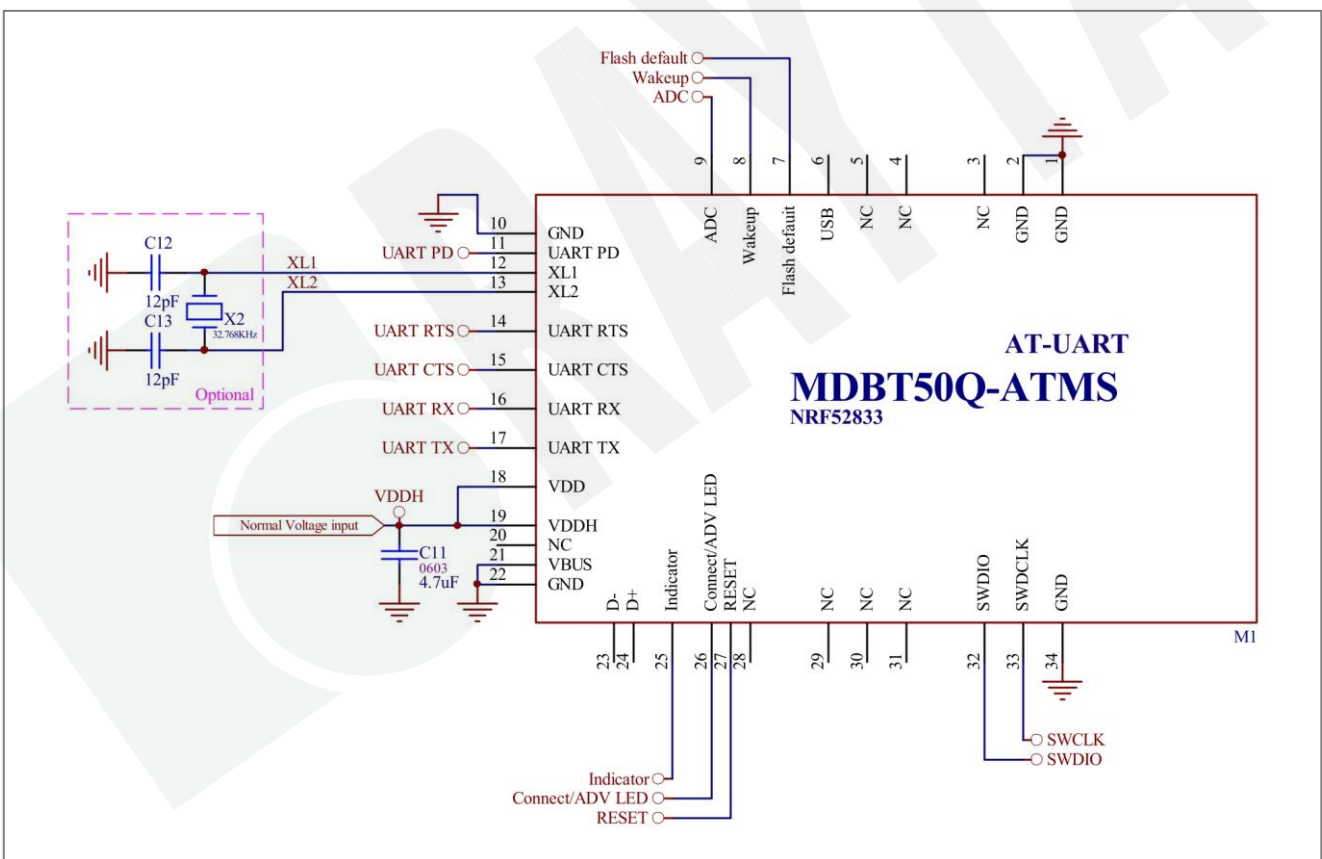

- UART Mode 2

**\*\* PIN 6 (USB) is NOT connected**

**\*\* Recommend using when VDDH is equal or greater than 3.6V. Supply power from VDDH.**

**\*\* GPIO logic level is 3.3V.**

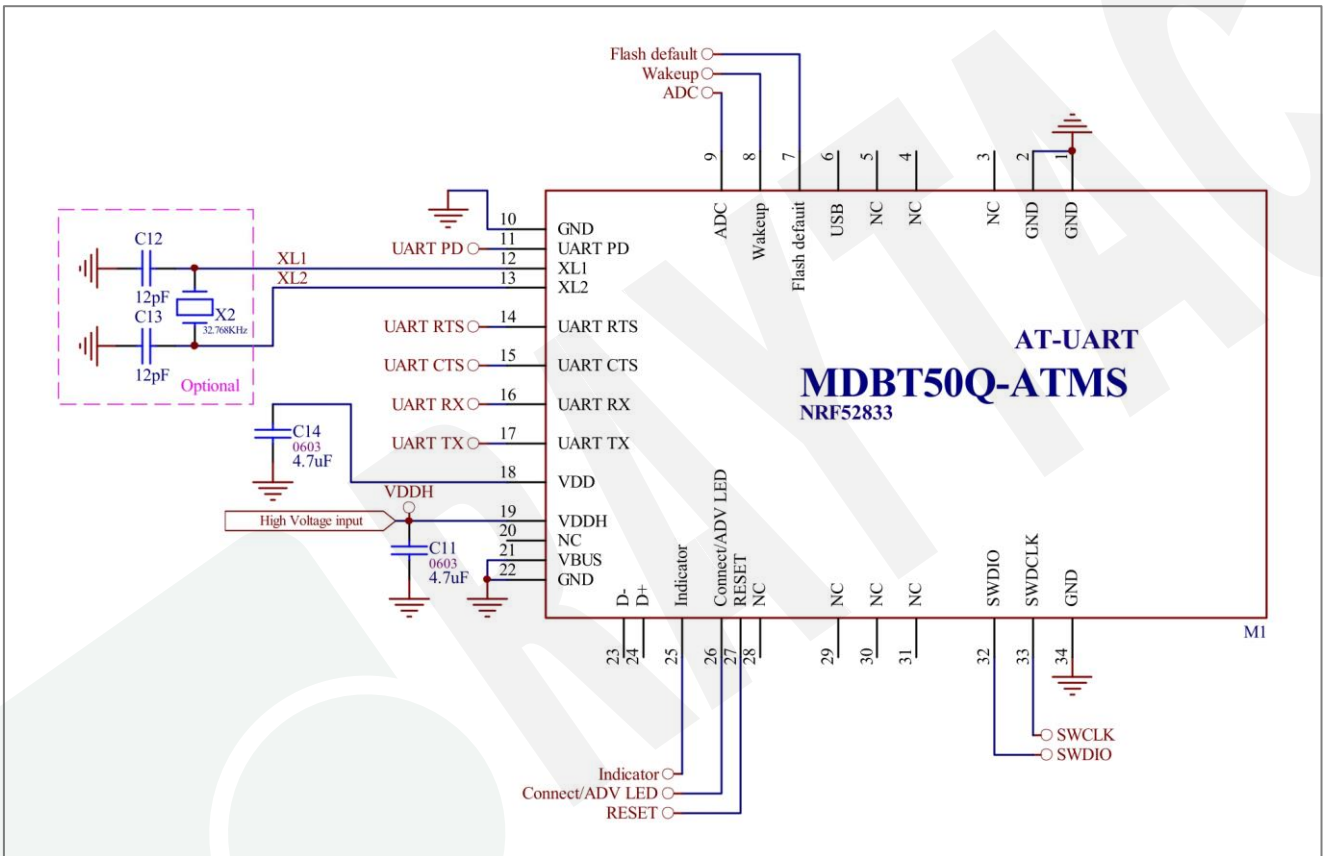

## 11.2. USB Mode

- USB Mode 1

\*\* PIN 6 (USB) connects to GND.

\*\* Recommend using when VDDH is less than 3.6V. Supply power from VDDH.

\*\* GPIO logic level follows the voltage of VDDH.

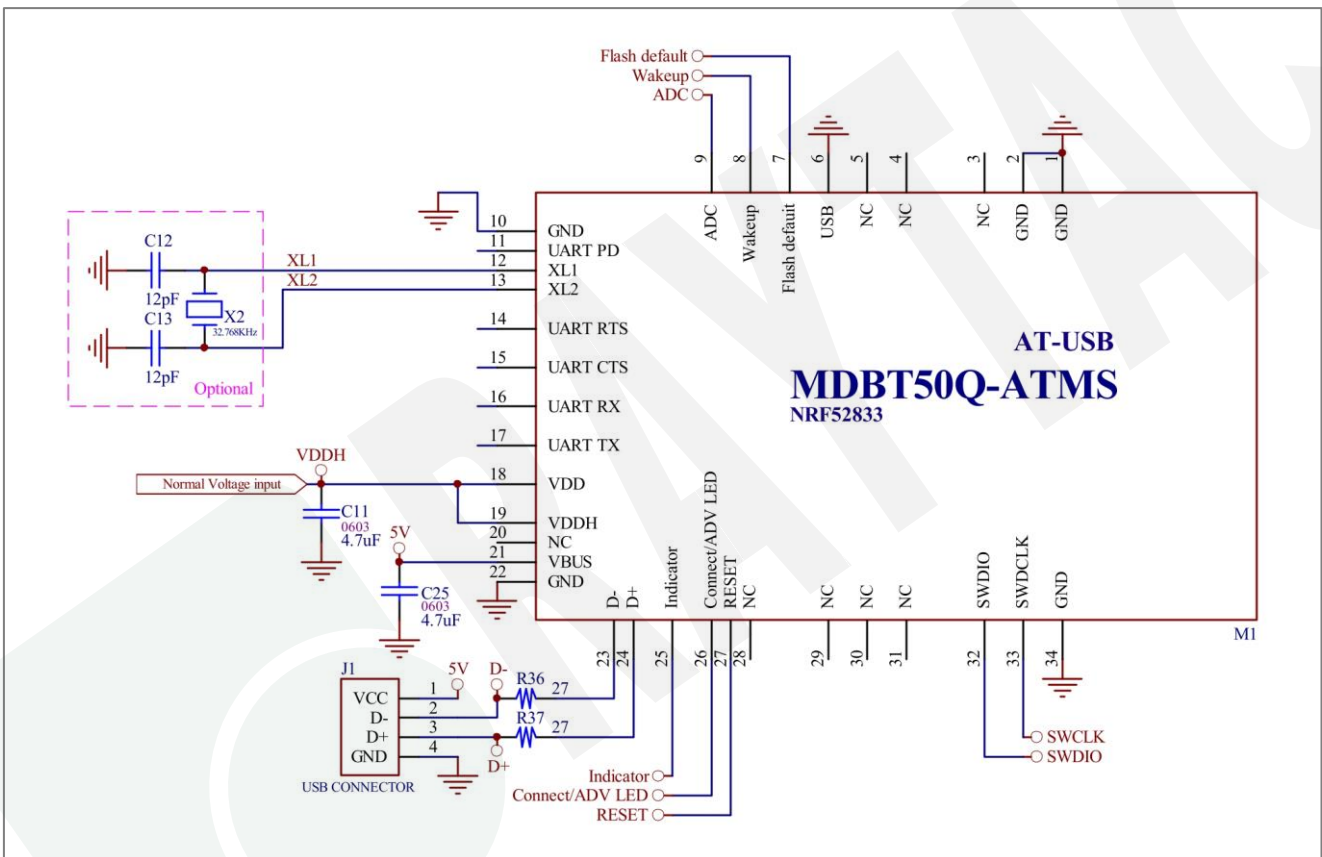



- USB Mode 2

**\*\* PIN 6 (USB) connects to GND.**

**\*\* Recommend using when the device is powered by USB**

**\*\* GPIO logic level is 3.3V.**

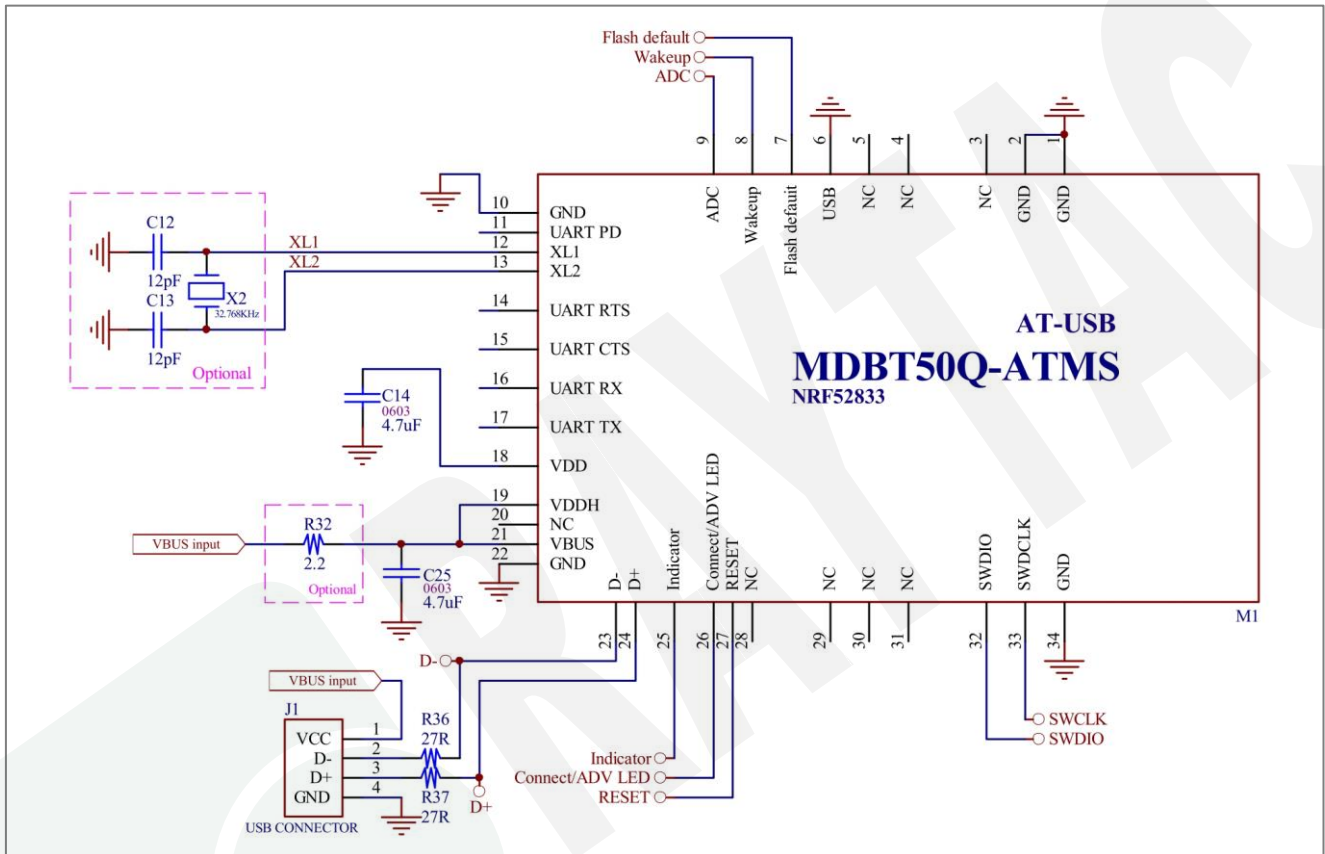

- USB Mode 3

**\*\* PIN 6 (USB) connects to GND.**

**\*\* Recommend using when VDDH is equal or greater than 3.6V. Supply power from VDDH.**

**\*\* GPIO logic level is 3.3V.**

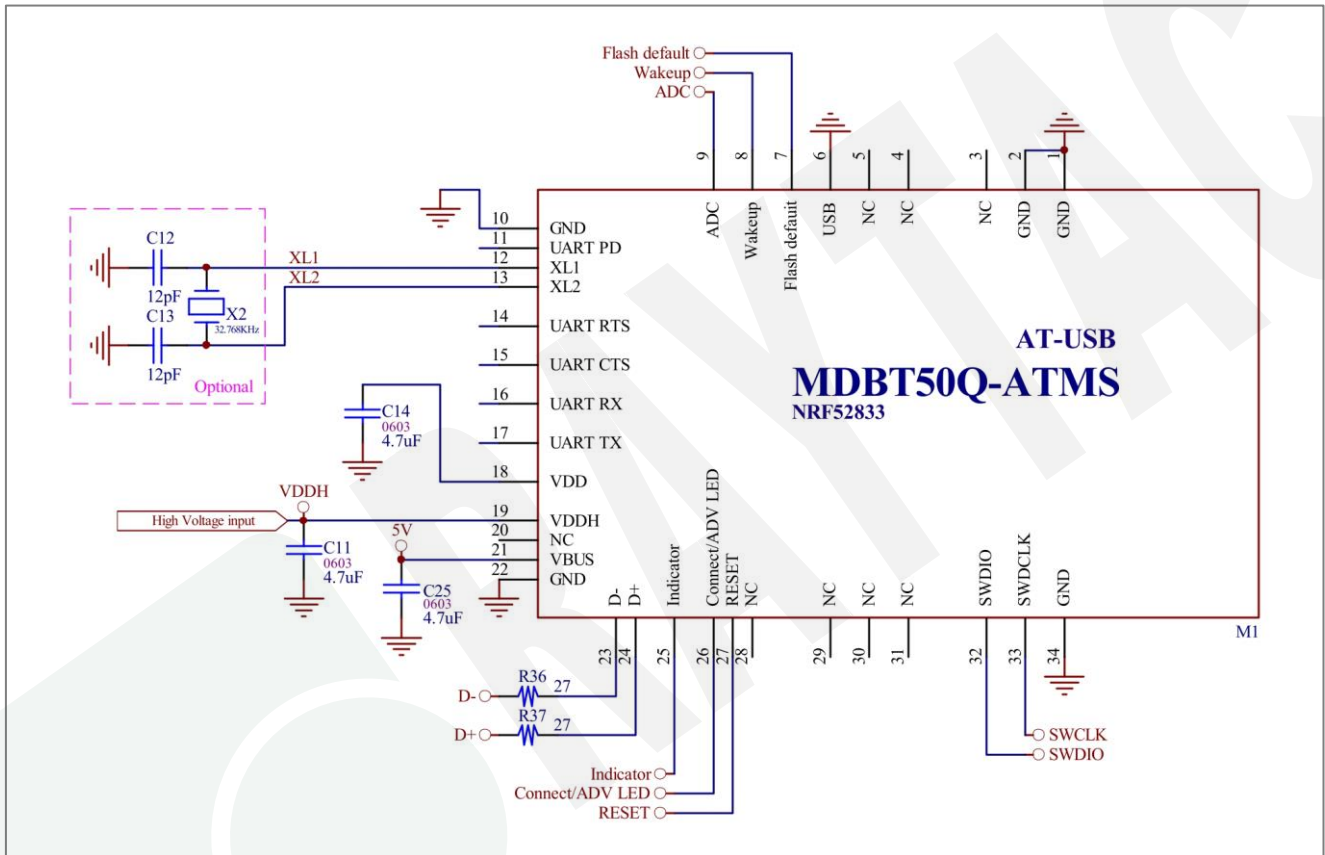

## 12. Certification

### 12.1. Declaration ID

#### BT 5.1

Declaration ID	QDID(s)	Company	Specification Name
D047708	139361 - End Product	Raytac Corporation	5.1

#### BT 5.2

Declaration ID	QDID(s)	Company	Specification Name
D053149	159932 - End Product	Raytac Corporation	5.2

<b>Profile Description</b>	<b>Service Description</b>
Alert Notification Profile	Alert Notification Service
Blood Pressure Profile	Blood Pressure Service
	Device Information Service
Cycling Speed & Cadence Profile	Cycling Speed & Cadence Service
	Device Information Service
Glucose Profile	Glucose Service
	Device Information Service
Health Thermometer Profile	Health Thermometer Service
	Device Information Service
Heart Rate Profile	Heart Rate Service
	Device Information Service
HID over GATT Profile	HID Service
	Battery Service
Proximity Profile	Link Loss Service
	Immediate Alert Service
	TX Power Service
Running Speed & Cadence Profile	Running Speed & Cadence Service
	Device Information Service
Time Profile	Time Profile Service
Glucose Profile (Central)	
Mesh Profile	Mesh Provisioning Service
	Mesh Proxy Service





## 12.2. FCC Certificate (USA)

**BLE 1Mbps & 2Mbps, IEEE 802.15.4 approved.**

				
<b>TCB</b>	<b>GRANT OF EQUIPMENT AUTHORIZATION</b>	<b>TCB</b>		
Certification Issued Under the Authority of the Federal Communications Commission By:				
Telefication B.V. Edisonstraat 12a Zevenaar, NL-6902 PK Netherlands		Date of Grant: 07/26/2018		
Raytac Corp. 5F., No.3, Jiankang Rd., Zhonghe Dist., New Taipei City,, 23586 Taiwan		Application Dated: 07/25/2018		
Attention: Venson Liao , R&D Manager				
<b>NOT TRANSFERABLE</b> EQUIPMENT AUTHORIZATION is hereby issued to the named GRANTEE, and is VALID ONLY for the equipment identified hereon for use under the Commission's Rules and Regulations listed below.				
FCC IDENTIFIER:	SH6MDBT50Q			
Name of Grantee:	Raytac Corp.			
Equipment Class:	Digital Transmission System			
Notes:	Bluetooth Low Energy & IEEE 802.15.4 Combo Module			
Modular Type:	Single Modular			
Grant Notes	FCC Rule Parts	Frequency Range (MHZ)	Output Watts	Frequency Emission Tolerance Designator
	15C	2402.0 - 2480.0	0.0066	
	15C	2405.0 - 2480.0	0.0066	
Modular Approval. This is a portable device. Power Output is conducted. This grant is valid only when the module is sold to OEM integrators and must be installed by the OEM or OEM integrators. End-users may not be provided with the module installation instructions. OEM integrators and end-users must be provided with transmitter operating conditions for satisfying RF exposure compliance.				
Certificate No.: 182180940/AA/00	Ramy Nabod Product Assessor			

## 12.3. TELEC Certificate (Japan)

**BLE 1 Mbps & 2 Mbps**

	<i>Certificate Technical Support Center Co., Ltd.</i> <b>RAB ID No. 018</b>
<b>Construction Type Certification</b>	
Registration No.	CSRT180280-1
Certificate Holder	Raytac Corporation 5F, No.3, Jiankang Rd., Zhonghe Dist., New Taipei City, 235, Taiwan
Product Category	Article 2, Paragraph 1, Item 19
Model Type or Name	MDBT50Q, MDBT50Q-1M, MDBT50Q-P1M, MDBT50Q-U1M, MDBT50Q-P, MDBT50Q-U
Type of Emission, Frequency and Antenna Power	F1D 2402MHz - 2480MHz (2MHz separation, 40 channels) 5.9704mW, 5.0816mW
Manufacturer	Raytac Corporation 5F, No.3, Jiankang Rd., Zhonghe Dist., New Taipei City, 235, Taiwan
Factory	Tech-Lin's Electronics Corp. 5F/11F, No. 778, Zhongzheng Rd., Zhonghe Dist., New Taipei City 23586, Taiwan R.O.C
Remarks	The scope of evaluation relates to the submitted documents and product only. It is only valid in conjunction with the Annex.
When the product is placed on the Japanese market, the Specified Radio Equipment marking as shown on the right must be attached on visible part of the product.	 <b>R 018-180280</b>
Witnesses that the certification is on Construction Type Certification under Article 38-24 of the Radio Law.	
Date of Certificate 2018/7/30	 Certification Examiner : Takuji Nakano  Certificate Technical Support Center Co., Ltd.
	
Address: 610-1 Kishine-cho, Kohoku-ku, Yokohama-City, 222-0034 Japan Tel.: +81 45 594 9185 • Fax: +81 45 594 9183 • E-mail: cert@cns-web.co.jp	

## IEEE 802.15.4



Certificate Technical Support Center Co., Ltd.  
RAB ID No. 018

### Construction Type Certification

Registration No. CSRT180280-1

Certificate Holder Raytac Corporation  
5F, No.3, Jiankang Rd., Zhonghe Dist., New Taipei City, 235, Taiwan

Product Category Article 2, Paragraph 1, Item 19

Model Type or Name MDBT50Q, MDBT50Q-1M, MDBT50Q-P1M, MDBT50Q-U1M,  
MDBT50Q-P, MDBT50Q-U

Type of Emission, Frequency and Antenna Power G1D 2405MHz - 2480MHz (5MHz separation, 16 channels)  
3.539mW/MHz

Manufacturer Raytac Corporation  
5F, No.3, Jiankang Rd., Zhonghe Dist., New Taipei City, 235, Taiwan

Factory Tech-Lin's Electronics Corp.  
5F/11F, No. 778, Zhongzheng Rd., Zhonghe Dist., New Taipei City 23586,  
Taiwan R.O.C

Remarks The scope of evaluation relates to the submitted documents and product only.  
It is only valid in conjunction with the Annex.

When the product is placed on the Japanese market, the Specified Radio Equipment marking as shown on the right must be attached on visible part of the product.



**R** 018-180280

Witnesses that the certification is on Construction Type Certification under Article 38-24 of the Radio Law.

Date of Certificate  
2018/7/30

*Takuji Nakano*

Certification Examiner : Takuji Nakano  
C&S Certificate Technical Support Center Co., Ltd.





Address: 610-1 Kishine-cho, Kohoku-ku, Yokohama-City, 222-0034 Japan  
Tel.: +81 45 594 9185 • Fax: +81 45 594 9183 • E-mail: cert@cns-web.co.jp



## 12.4. NCC Certificate (Taiwan)

**BLE 1Mbps & 2Mbps, IEEE 802.15.4 approved.**

### **MDBT50Q-U**

	<b>台灣檢驗科技股份有限公司 電信管制射頻器材型式認證證明</b>
一、申請者：	勁達國際電子有限公司
二、地址：	臺北市大安區和平東路1段145號5樓之1
三、製造廠商：	勁達國際電子有限公司
四、器材名稱：	低功耗藍牙及 IEEE 802.15.4 整合模組
五、廠牌：	Raytac
六、型號：	MDBT50Q-U
七、發射功率(電場強度)：	詳細射頻規格如備註欄
八、工作頻率：	詳細射頻規格如備註欄
九、審驗日期：	108年10月24日
十、審驗合格標籤式樣：	
十一、警語或標示要求：	(器材本體、使用手冊、外包裝盒等應遵守下列標示要求)
1.	應依審驗合格標籤或符合性聲明標籤式樣自製標籤黏貼或印鑄於電信管制射頻器材本體明顯處，並於包裝盒標示本會標章，始得開陳列或販賣。
2.	電信管制射頻器材應依本會或相關技術規範規定於指定位置標示中文警語。
3.	經授權使用射頻模組(組件)之審驗合格標籤者，應於最終產品說明書及包裝盒提供充分與正確之資訊。
4.	於網際網路販賣取得審驗證明之電信管制射頻器材者，應於該網際網路網頁提供審驗合格標籤或符合性聲明標籤資訊。
5.	使用手冊應標示下列資訊： (1)經型式認證合格之低功率射頻電機，非經許可，公司、商號或使用者均不得擅自變更頻率、加大功率或變更原設計之特性及功能。低功率射頻電機之使用不得影響飛航安全及干擾合法通信；經發現有干擾現象時，應立即停用，並改善至無干擾時方得繼續使用。前項合法通信，指依電信法規定作業之無線電通信。低功率射頻電機須忍受合法通信或工業、科學及醫療用電波輻射性電機設備之干擾。
6.	本器材之審驗範圍僅限無線射頻硬體功能，不及於器材之資通安全檢測。



型式認證號碼：CCAM18LP0825T4      第 1 頁，共 2 頁      本證書與續頁分開使用無效



## 12.5. CE (EU) & RCM (Australia & New Zealand) Test Report

**BLE 1 Mbps & 2 Mbps**

	Report No.: E2/2018/50088-02 Page: 1 of 73
<b>RED (2014/53/EU) ETSI EN 300 328 v2.2.2 : 2019 &amp; Australian/New Zealand Standard AS/NZS 4268:2017 TEST REPORT</b>	
<b>FOR</b>	
<b>Applicant:</b>	Raytac Corporation 5F, No.3, Jiankang Rd., Zhonghe Dist., New Taipei City, 235, Taiwan
<b>Product Name:</b>	Bluetooth Low Energy & IEEE 802.15.4 Combo Module
<b>Brand Name:</b>	Raytac
<b>Model No.:</b>	MDBT50Q, MDBT50Q-P, MDBT50Q-U
<b>Model Difference:</b>	Different Antenna Type
<b>Report Number:</b>	E2/2018/50088-02
<b>Issue Date:</b>	Jun. 15, 2020
<b>Date of Test:</b>	May 31, 2018 ~ Jun. 28, 2018 (Original test), Jun. 05, 2020 (Update receiver blocking)
<b>Date of EUT Received:</b>	May 31, 2018 (Original test), Apr. 16, 2020 (Update receiver blocking)
<b>We hereby certify that:</b> The above equipment was tested by SGS Taiwan Ltd., Central RF Lab for compliance with the requirements set forth in the European Standard ETSI EN 300 328 v2.2.2: 2019 under RED 2014/53/EU and Australian/New Zealand Standard AS/NZS 4268:2017, Row 59. Test report to determine compliance with AS/NZS 4268 requirements. The results of testing in this report apply to the product system that was tested only. Other similar equipment will not necessarily produce the same results due to production tolerance and measurement uncertainties.	
<b>Approved By:</b>	 <u>Jay Lin / Asst. Supervisor</u>
	 

## IEEE 802.15.4



Report No.: E2/2018/50089-02  
Page: 1 of 57

### RED (2014/53/EU) ETSI EN 300 328 v2.2.2: 2019 & Australian/New Zealand Standard AS/NZS 4268:2017 TEST REPORT

FOR

**Applicant:** Raytac Corporation  
5F, No.3, Jiankang Rd., Zhonghe Dist., New Taipei City, 235,  
Taiwan

**Product Name:** Bluetooth Low Energy & IEEE 802.15.4 Combo Module

**Brand Name:** Raytac

**Model No.:** MDBT50Q, MDBT50Q-P, MDBT50Q-U

**Model Difference:** Different Antenna Type

**Report Number:** E2/2018/50089-02

**Issue Date:** Jun. 11, 2020

**Date of Test:** May 31, 2018 ~ Jul. 23, 2018 (Original test),  
Jun. 08, 2020 (Update receiver blocking)

**Date of EUT Received:** May 31, 2018 (Original test),  
Apr. 16, 2020 (Update receiver blocking)

We hereby certify that:

The above equipment was tested by SGS Taiwan Ltd., Central RF Lab for compliance with the requirements set forth in the European Standard ETSI EN 300 328 v2.2.2: 2019 under RED 2014/53/EU and Australian/New Zealand Standard AS/NZS 4268:2017. Test report to determine compliance with AS/NZS 4268 requirements. The results of testing in this report apply to the product system that was tested only. Other similar equipment will not necessarily produce the same results due to production tolerance and measurement uncertainties.

Approved By: \_\_\_\_\_

*Jay Lin*  
Jay Lin / Asst. Supervisor





SGS Reference No: MH/2018/60113C-01

## VERIFICATION OF EMC COMPLIANCE

Verification No. : MH/2018/60113C-01  
Representative Model No. : MDBT50Q  
Added Model(s) : MDBT50Q-P, MDBT50Q-U  
Product Name : Bluetooth Low Energy & IEEE 802.15.4 Combo Module  
Brand Name : Raytac  
Applicant : Raytac Corporation  
Address of Applicant : 5F, No.3, Jiankang Rd., Zhonghe Dist., New Taipei City, 235, Taiwan  
Test Report Number : MH/2018/60113-01  
Date of Issue : Oct. 02, 2019  
Applicable Standards : EN 301 489 -1 v2.2.0 : 2017-03 (Draft)  
EN 301 489 -17 v3.2.0 : 2017-03 (Draft)  
EN 55032 : 2015+AC:2016-07  
EN 61000-4-2 : 2009, EN 61000-4-3 : 2006+A1:2008+A2:2010

### **Conclusion**

Please be noted that the VERIFICATION MH/2018/60113C-01 will replace the previous MH/2018/60113C as the new version. Also be pay attention that MH/2018/60113C is ineffective anymore from now on.

The apparatus meets the requirements of the above standards and hence compliance the essential requirements under article 3.1b of the RED (2014/53/EU) Directive.

\*This verification is only valid for the equipment and configuration described, and in conjunction with the test report as detailed above.

Authorized Signatory:

SGS TAIWAN LTD.  
Eddy Cheng  
Technical Asst. Supervisor



## 12.6. IC Certificate (Canada)

**BLE 1Mbps & 2Mbps, IEEE 802.15.4 approved.**

<p>telefication bv The Netherlands Chamber of Commerce 51565536 www.telefication.com</p>		 <p><b>telefication</b></p>	
<p><b>TECHNICAL ACCEPTANCE CERTIFICATE</b></p>		<p><b>CERTIFICAT D'ACCEPTABILITÉ TECHNIQUE</b></p>	
CERTIFICATION No. No. DE CERTIFICATION	8017A-MDBT50QU		
TELEFICATION No. No. DE TELEFICATION	192170354/AA/00		
TEST SITE No. No. DE LABORATOIRE	4620A-5		
ISSUED TO DELIVRÉ A	Raytac Corporation		
TYPE OF EQUIPMENT GENRE DE MATÉRIEL	Bluetooth device Spread Spectrum/Digital Device (2400-2483.5 MHz)		
TRADE NAME AND MODEL MARQUE ET MODELE	Raytac / MDBT50Q-U1M Raytac / MDBT50Q-U		
CERTIFIED TO CERTIFIÉ SELON LE	SPECIFICATION CAHIER DES CHARGES	RSS-102 RSS-247	ISSUE EDITION
			5 2
<p>Certification of equipment means only that the equipment has met the requirements of the above-noted specification. Licence applications, where applicable to use certified equipment, are acted on accordingly by the ISED issuing office and will depend on the existing radio environment, service and location of operation. This certificate is issued on condition that the holder complies and will continue to comply with the requirements and procedures issued by ISED. The equipment for which this certificate is issued shall not be manufactured, imported, distributed, leased, offered for sale or sold unless the equipment complies with the applicable technical specifications and procedures issued by ISED.</p>		<p>La certification du matériel signifie seulement que le matériel a satisfait aux exigences de la norme indiquée ci-dessus. Les demandes de licences nécessaires pour l'utilisation du matériel certifié sont traitées en conséquence par le bureau de délivrance d'ISDE et dépendent des conditions radio ambiantes, du service et de l'emplacement d'exploitation. Le présent certificat est délivré à la condition que le titulaire satisfasse et continue de satisfaire aux exigences et aux procédures d'ISDE. Le matériel à l'égard duquel le présent certificat est délivré ne doit pas être fabriqué, importé, distribué, loué, mis en vente ou vendu à moins d'être conforme aux procédures et aux spécifications techniques applicables publiées par ISDE.</p>	
<p>ISSUED BY TELEFICATION BV (NL0001), RECOGNIZED CERTIFICATION BODY BY INNOVATION, SCIENCE AND ECONOMIC DEVELOPMENT CANADA DELIVRÉ PAR TELEFICATION BV (NL0001), ORGANISME DE CERTIFICATION RECONNU PAR INNOVATION, SCIENCES ET DÉVELOPPEMENT ÉCONOMIQUE CANADA</p>			
<p><i>I hereby attest that the subject equipment was tested and found in compliance with the above-noted specification. J'atteste, par la présente, que le matériel a fait l'objet d'essai et a été jugé conforme à la spécification ci-dessus</i></p>			
DATE 25 Oct 2019 BY	Gürhan Vural Product Assessor		
This certificate has one annex.			

## 12.7. SRRC Certificate (China)

**BLE 1Mbps & 2Mbps, IEEE 802.15.4 approved.**



## 12.8. KC Certificate (South Korea)

**BLE 1Mbps & 2Mbps, IEEE 802.15.4 approved.**

2CC6-E6D4-B6AA-9E64

<b>방송통신기자재등의 적합인증서</b> <i>Certificate of Broadcasting and Communication Equipments</i>	
상호 또는 성명 <i>Trade Name or Applicant</i>	Raytac Corporation
기자재명칭(명칭) <i>Equipment Name</i>	특정소출력 무선기기(무선데이터통신시스템용 무선기기)
기본모델명 <i>Basic Model Number</i>	MDBT50Q-U
파생모델명 <i>Series Model Number</i>	MDBT50Q, MDBT50Q-P
인증번호 <i>Certification No.</i>	R-C-ryt-MDBT50Q
제조사/제조국가 <i>Manufacturer/ Country of Origin</i>	Raytac Corporation / 대만
인증연월일 <i>Date of Certification</i>	2018-08-17
기타 <i>Others</i>	
<p>위 기자재는 「전파법」 제58조의2 제2항에 따라 인증되었음을 증명합니다.                      It is verified that foregoing equipment has been certificated under the Clause 2, Article 58-2 of Radio Waves Act.</p> <p style="text-align: right;">2018년(Year) 08월(Month) 17일(Day)</p> <p style="text-align: center;">국립전파연구원장 </p> <p style="text-align: center;"><i>Director General of National Radio Research Agency</i></p> <p style="text-align: center; font-size: small;">                         ※ 인증 받은 방송통신기자재는 반드시 "적합성평가표시" 를 부착하여 유통하여야 합니다.                          위반시 과태료 처분 및 인증이 취소될 수 있습니다.                     </p>	

## 12.9. RoHS & REACH Report

Please visit "[Support](#)" page of our website to download.

## 12.10. End-Product Label

It is suggested using following content adding to package or user manual or label to obey the regulation. Any rules of end-product label shall refer to each certification for final reference.

### 12.10.1. FCC (USA)

The FCC statement should be included in the user manual when there is not enough space on label. Otherwise, it should be included on the label.

"This device complies with part 15 of the FCC rules. Operation is subject to the following two conditions. (1) This device may not cause harmful interference. (2) This device must accept any interference received, including interference that may cause undesired operation."

The final end product must be labeled in a visible area with the following: "Contain FCC ID: SH6MDBT50Q".

### 12.10.2. TELEC (Japan)

When manufacturer is placing the product on the Japanese market, the product must be affixed with the following Specified Radio Equipment marking:



### 12.10.3. NCC (Taiwan)

請依下列標籤式樣自製標籤，標貼或印鑄於器材本體明顯處，始得販賣或公開陳列。

**MDBT50Q-U Series**



平台廠商必須於平台上標示字樣「本產品內含射頻模組：ID 編號 CCAM18LP0825T4」。

「平台」定義如下：若器材組裝本案模組，消費者仍能正常使用該器材主要功能，該器材得視為平台。若器材不組裝本案模組，消費者不能正常使用該器材主要功能，該器材不能視為平台。該類不同廠牌型號器材組裝本案審驗模組後，須分別申請型式認證。

### 12.10.4. IC (Canada)

The IC statement should be included in the user manual when there is not enough space on label. Otherwise, it should be included on the label.

“This device complies with Industry Canada license-exempt RSS Standard(s). Operation is subject to the following two conditions. (1) This device may not cause harmful interference. (2) This device must accept any interference received, including interference that may cause undesired operation.

Le présent appareil est conforme aux CNR d'Industrie Canada applicables aux appareils radio exempts de licence. L'exploitation est autorisée aux deux conditions suivantes: (1) l'appareil ne doit pas produire de brouillage, et (2) l'utilisateur de l'appareil doit accepter tout brouillage radioélectrique subi, même si le brouillage est susceptible d'en compromettre le fonctionnement.”

The final end product must be labeled in a visible area with the following: “Contain IC ID: 8017A-MDBT50QU”.



## 13. Notes and Cautions

Module is not designed to last for a lifetime. Like general products, it is expected to be worn out after continuous usage through the years. To assure that product will perform better and last longer, please make sure you:

- Follow the guidelines of this document while designing circuit/end-product. Any discrepancy of core Bluetooth technology and technical specification of IC should refer to definition of Bluetooth Organization and Nordic Semiconductor as final reference.
- Do not supply voltage that is not within range of specification.
- Eliminate static electricity at any cost when working with the module as it may cause damage. It is highly recommended adding anti-ESD components to circuit design to prevent damage from real-life ESD events. Anti-ESD methods can be also applied in mechanical design.
- Do not expose modules under direct sunlight for long duration. Modules should be kept away from humid and salty air conditions, and any corrosive gasses or substances. Store it within  $-40^{\circ}\text{C}$  to  $+125^{\circ}\text{C}$  before and after installation.
- Avoid any physical shock, intense stress to the module or its surface.
- Do not wash the module. No-Clean Paste is used in production. Washing it will oxidize the metal shield and have chemistry reaction with No-Clean Paste. Functions of the module are not guaranteed if it has been washed.

The module is not suitable for life support device or system and not allowed to be used in destructive device or systems in any direct or indirect ways. The customer agrees to indemnify Raytac for any losses when applying modules in applications such as the ones described above.

# 14. Basic Facts for nRF52 Family

Below chart shows basic spec for Nordic nRF52 family, which is helpful to understand the differences between each SoC. Any discrepancy shall refer to Nordic’s technical document as final reference.

See [Full List of Raytac’s BLE Modules](#) for complete model no. of each item.

Nordic Solution	nRF52840	nRF52833	nRF52820	nRF52832	nRF52810	nRF52811	nRF52805
RAYTAC Model No. (MDBTXX)	50Q series	50Q series 50 series	50 series	42Q series 42 series 42V series	42Q series	42Q Series	42T series 42TV series
Bluetooth Direction Finding		V	V			V	
Bluetooth 5 Long Range (125kbps)	V	V	V			V	
Bluetooth 5 High Speed	V	V	V	V	V	V	V
Bluetooth 5 Ad. Extension (x8)	V	V	V	V	V	V	V
Flash (kBytes)	1024	512	256	512	192	192	192
RAM (kBytes)	256	128	32	64	24	24	24
ANT Plus	V	V	V	V	V	V	
IEEE 802.15.4	V	V	V			V	
ARM® TrustZone® Cryptocell	V						
USB	V	V	V				
QSPI	V						
NFC	V	V		V			
I2S	V	V		V			
SPI, TWI, UART, PWM	V	V	V	V	V	V	without PWM
PDM	V	V		V	V	V	
ADC, Comparators	V	V	without ADC	V	V	V	without comparators
Supply Range (V)	1.7 to 5.5	1.7 to 5.5	1.7 to 5.5	1.7 to 3.6	1.7 to 3.6	1.7 to 3.6	1.7 to 3.6

## 15. Useful Links

- **Nordic Infocenter:** <https://infocenter.nordicsemi.com/index.jsp>  
All the necessary technical files and software development kits of Nordic's chip are on this website.
- **Nordic Developer Zone:** <https://devzone.nordicsemi.com/questions/>  
A highly recommended website for firmware developer. Interact with other developers and Nordic's employees will help with your questions. The site also includes tutorials in detail to help you get started.
- **Official Page of nRF52833 :** <https://www.nordicsemi.com/Products/Low-power-short-range-wireless/nRF52833>  
A brief introduction to nRF52833 and download links for Nordic's developing software and SoftDevices.

# History of Firmware Revision

<b>FW Ver.</b>	<b>Compatible HW Build</b>	<b>Release Date</b>	<b>Description of Revision</b>	<b>Note</b>
1.0		2020/05/30	1 <sup>st</sup> release.	99-52833-03A
1.1		2020/10/20	(1) Fixed HardFault_Handler error when sending large amounts of data in Central mode. (2) Fixed error of output data when receiving long length of data in scan beacon mode. (3) Added "AT?BLESTATUS" command.	99-52833-03B

# Full List of Raytac's BLE Modules

## ● MDBT40 Series

Series	Nordic Solution	Raytac No.	IC Ver.	Antenna	RAM	Flash Memory
MDBT40	nRF51822	MDBT40-256V3	3	Chip Antenna	16 kb	256 K
		MDBT40-256RV3			32 kb	256 K
MDBT40-P	nRF51822	MDBT40-P256V3	3	PCB Antenna	16 kb	256 K
		MDBT40-P256RV3			32 kb	256 K

## ● MDBT42Q Series (QFN Package IC)

Series	Nordic Solution	Raytac No.	IC Ver.	Antenna	RAM	Flash Memory
MDBT42Q	nRF52832	MDBT42Q-512KV2	2	Chip Antenna	64 kb	512 K
	nRF52810	MDBT42Q-192KV2	2		24 kb	192 K
	nRF52811	MDBT42Q-192KL	1			
MDBT42Q-P	nRF52832	MDBT42Q-P512KV2	2	PCB Antenna	64 kb	512 K
	nRF52810	MDBT42Q-P192KV2	2		24 kb	192 K
	nRF52811	MDBT42Q-P192KL	1			
MDBT42Q-U	nRF52832	MDBT42Q-U512KV2	2	u.FL Connector	64 kb	512 K

## ● MDBT42 Series (WLCSP Package IC)

Series	Nordic Solution	Raytac No.	IC Ver.	Antenna	RAM	Flash Memory
MDBT42	nRF52832	MDBT42-512KV2	2	Chip Antenna	64 kb	512 K
MDBT42-P		MDBT42-P512KV2		PCB Antenna		

## ● MDBT42V Series (WLCSP Package IC)

Series	Nordic Solution	Raytac No.	IC Ver.	Antenna	RAM	Flash Memory
MDBT42V	nRF52832	MDBT42V-512KV2	2	Chip Antenna	64 kb	512 K
MDBT42V-P		MDBT42V-P512KV2		PCB Antenna		

## ● MDBT42T Series (WLCSP Package IC)

Series	Nordic Solution	Raytac No.	IC Ver.	Antenna	RAM	Flash Memory
MDBT42T	nRF52805	MDBT42T-192K	1	Chip Antenna	24 kb	192 K
MDBT42T-P		MDBT42T-P192K		PCB Antenna		

## ● MDBT42TV Series (WLCSP Package IC)

Series	Nordic Solution	Raytac No.	IC Ver.	Antenna	RAM	Flash Memory
MDBT42TV	nRF52805	MDBT42TV-192K	1	Chip Antenna	24 kb	192 K
MDBT42TV-P		MDBT42TV-P192K		PCB Antenna		

## ● MDBT50Q Series (aQFN Package IC)

Series	Nordic Solution	Raytac No.	IC Ver.	Antenna	RAM	Flash Memory
MDBT50Q	nRF52840	MDBT50Q-1MV2	2	Chip Antenna	256 kb	1 MB
	nRF52833	MDBT50Q-512K	1		128 kb	512 kb
MDBT50Q-P	nRF52840	MDBT50Q-P1MV2	2	PCB Antenna	256 kb	1 MB
	nRF52833	MDBT50Q-P512K	1		128 kb	512 kb
MDBT50Q-U	nRF52840	MDBT50Q-U1MV2	2	u.FL Connector	256 kb	1 MB
	nRF52833	MDBT50Q-U512K	1		128 kb	512 kb
Dongle	nRF52840	MDBT50Q-RX	1, 2	PCB Antenna	256 kb	1 MB

## ● MDBT50 Series (QFN Package IC)

Series	Nordic Solution	Raytac No.	IC Ver.	Antenna	RAM	Flash Memory
MDBT50	nRF52820	MDBT50-256R	1	Chip Antenna	32 kb	256 kb
	nRF52833	MDBT50-512K	1		128 kb	512 kb
MDBT50-P	nRF52820	MDBT50-P256R	1	PCB Antenna	32 kb	256 kb
	nRF52833	MDBT50-P512K	1		128 kb	512 kb

## ● **MDBT53 Series (WLCSP Package IC)**

Series	Nordic Solution	Raytac No.	IC Ver.	Antenna	RAM	Flash Memory
MDBT53	nRF5340	MDBT53-1M	1	Chip Antenna	512 kb	1 MB
MDBT53-P	nRF5340	MDBT53-P1M	1	PCB Antenna	512 kb	1 MB
MDBT53-U	nRF5340	MDBT53-U1M	1	u.FL Connector	512 kb	1 MB

## ● **MDBT53V Series (WLCSP Package IC)**

Series	Nordic Solution	Raytac No.	IC Ver.	Antenna	RAM	Flash Memory
MDBT53V	nRF5340	MDBT53V-1M	1	Chip Antenna	512 kb	1 MB
MDBT53V-P	nRF5340	MDBT53V-P1M	1	PCB Antenna	512 kb	1 MB



# Release Note

- 2022/07/11: Version A: 1<sup>st</sup> release.
- 2023/05/24 Version B
  - (1) Updated drawing in Chapter 5 for a better understanding of PCB measurement & RF Layout Suggestion.

