

Tous droits strictement reserves. Reproduction ou communication a des tiers interdite sous quelque forme que ce soit sans autorisation ecrite du proprietaire. Propriete de c FCI. Droits de reproduction FCI.

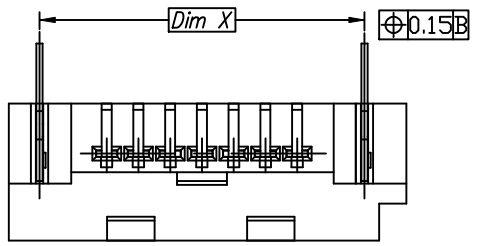

All rights strictly reserved. Reproduction or issue to third parties in any form whatever is not permitted without written authority from the proprietor. Property of FCI. Copyright FCI.

10035692-XXXXLF

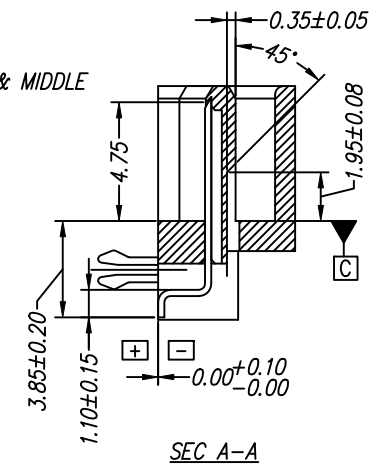
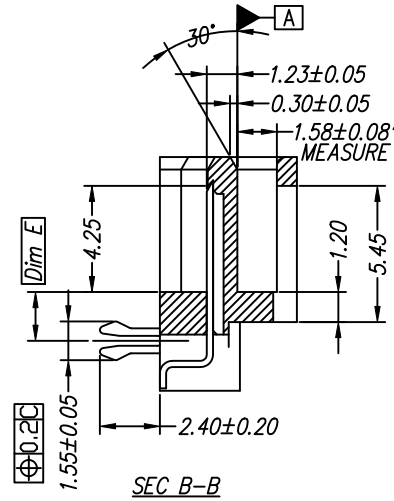
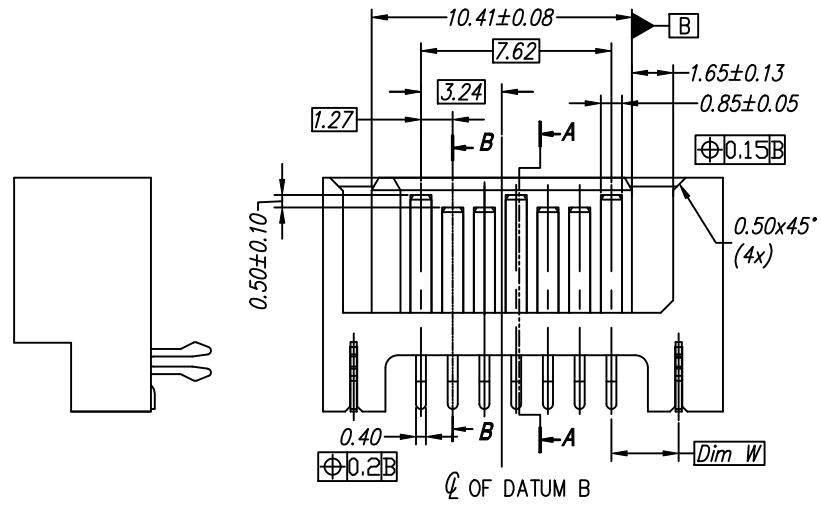
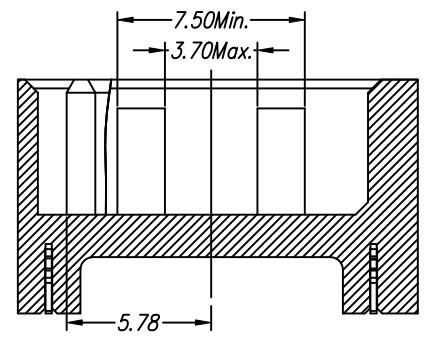
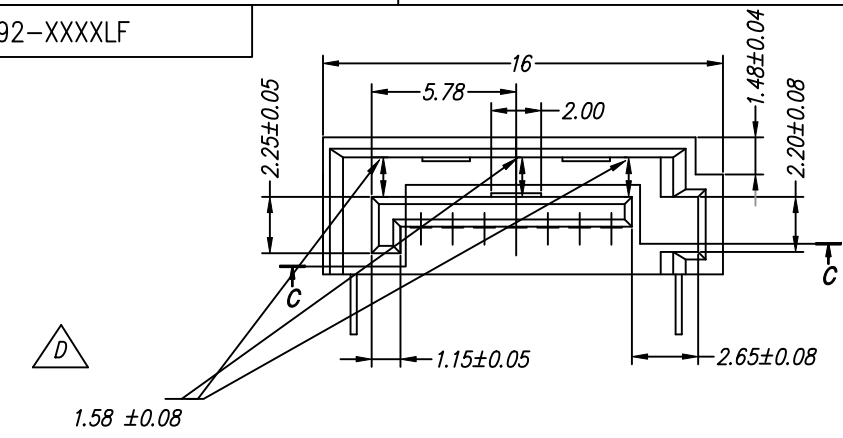

mat'l. code				tolerances unless otherwise specified				CUSTOMER COPY		FCI www.fciconnect.com	
ltr	ecn no	dr	date	linear	.X ± 0.30	projection		title			
A	T05-0213	L.W	09/09/05		.XX ± 0.20	MM		S-ATA SIGNAL PLUG SMT R/A TYPE ASS'Y			
B	T06-0181	S.Lin	11/01/06		.XXX ± 0.10	MM		product family SATA			
C	T08-1100	S.Lin	06/10/08	angles	0° ± 2°	MM		size dwg no		code	
D	T10-0185	S.Lin	10'-12-08	dr	WADE LIU 09/09/05	MM		scale		sheet	
				engr	WADE LIU 09/09/05	NA		A4		1 of 2	
				chr	WADE LIU 09/09/05			10035692			
				appd	STERLING LIN 09/09/05						
sheet index	revision sheet	D	D								
		1	2								



PRODUCT NO.	DIM 'W'	DIM 'X'	DIM 'E'	DIM 'F'	PACKING	NOTE
10035692-001LF	2.69	13.00	1.95	2.40	TUBE	
10035692-001TLF	2.69	13.00	1.95	2.40	T&R	
10035692-011LF	2,56	12,74	0,95	3.36	TUBE	
10035692-001THLF	2.69	13.00	1.95	2.40	T&R	H FREE



NOTES :

1. MATERIAL

- i) HOUSING : HIGH TEMPERATURE THERMOPLASTIC UL94V-0 , BLACK
- ii) TERMINAL : COPPER ALLOY
- iii) HOLD DOWN : COPPER ALLOY

2. FINISH

- i) TERMINAL : 15u" min Au PLATING AT CONTACT POINT
100u" min Sn PLATING AT SOLDER TAIL WITH NICKEL UNDERPLATE

- ii) HOLD DOWN : 100-200 u" Sn PLATING.

3. P/N : 10035692-XXXLF

THE HOUSING WILL WITHSTAND EXPOSURE TO 260 DEGREE C PEAK TEMPERATURE FOR 10 SECONDS IN A WAVE SOLDER APPLICATION WITH 1.6MM MINIMUM THICK CIRCUIT BOARD.

4. PRODUCT SPEC: GS-12-194

110-634 (10035692-001TLF ONLY)

5. PACKING SPEC: GS-14-840

PACKING TUBE&STOPPER:10020959-004&10026026-004

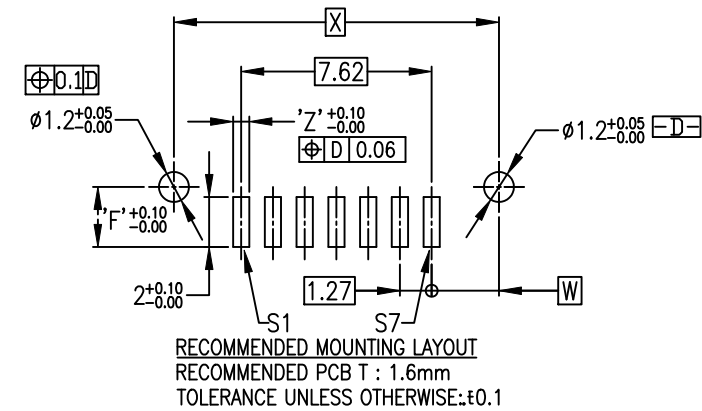

mat'l. code				tolerances unless otherwise specified				CUSTOMER COPY		FCI www.fciconnect.com	
ltr	ecn no	dr	date	linear	.X ± 0.30			projection	title		
A	T05-0213	L.W	09/09/05		.XX ± 0.20				S-ATA SIGNAL PLUG SMT R/A TYPE ASS'Y		
B	T06-0181	S.Lin	11/01/06		.XXX ± 0.10						
C	T08-1100	S.Lin	06/10/08	angles	0° ±2°						
D	T10-0185	S.Lin	10'-12-08	dr	WADE LIU	09/09/05	MM	product family		code	
				engr	WADE LIU	09/09/05		SATA		TWN	
				chr	WADE LIU	09/09/05		size		sheet	
				appd	STERLING LIN	09/09/05		dwg no		2 of 2	
sheet index	revision sheet	D	D				scale	A4	10035692		
		1	2				NA				