

THIS DRAWING IS UNPUBLISHED. RELEASED FOR PUBLICATION
 © COPYRIGHT - By - ALL RIGHTS RESERVED.

REVISIONS				
P	LTR	DESCRIPTION	DATE	APVD
E		FREE STATE DIMENSION UPDATED	01JUL2019	MB

- 1 CONTINUOUS STRIP ON REELS WITH TERMINALS LOCATED ON 10.41±0.08[.410±.003] CENTERS.
- 2 SLOT ACCEPTS 0.72-0.86mm [#21-#19.5] AWG COPPER MAGNET WIRE. 2 WIRES OF THE SAME SIZE MAX PER SLOT.
- 3 CONTACT LEAF ACCEPTS 0.81[.032] THICK POKE-IN TAB, (REFERENCE TAB DRAWING 1217324-1).
- 4 TIN PLATE OVER NICKEL UNDERPLATE.
- 5 TIN PLATE.

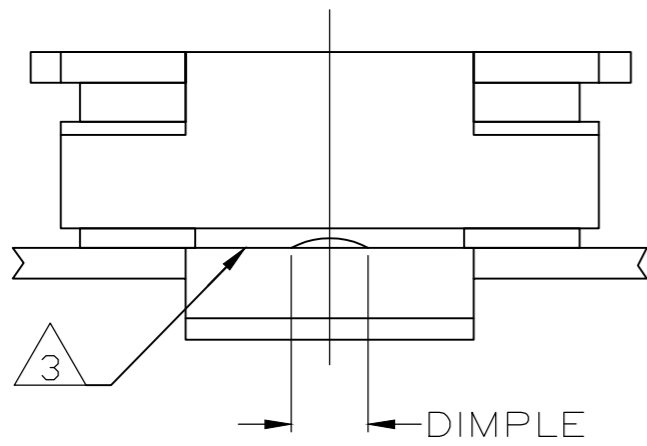

DIMPLE

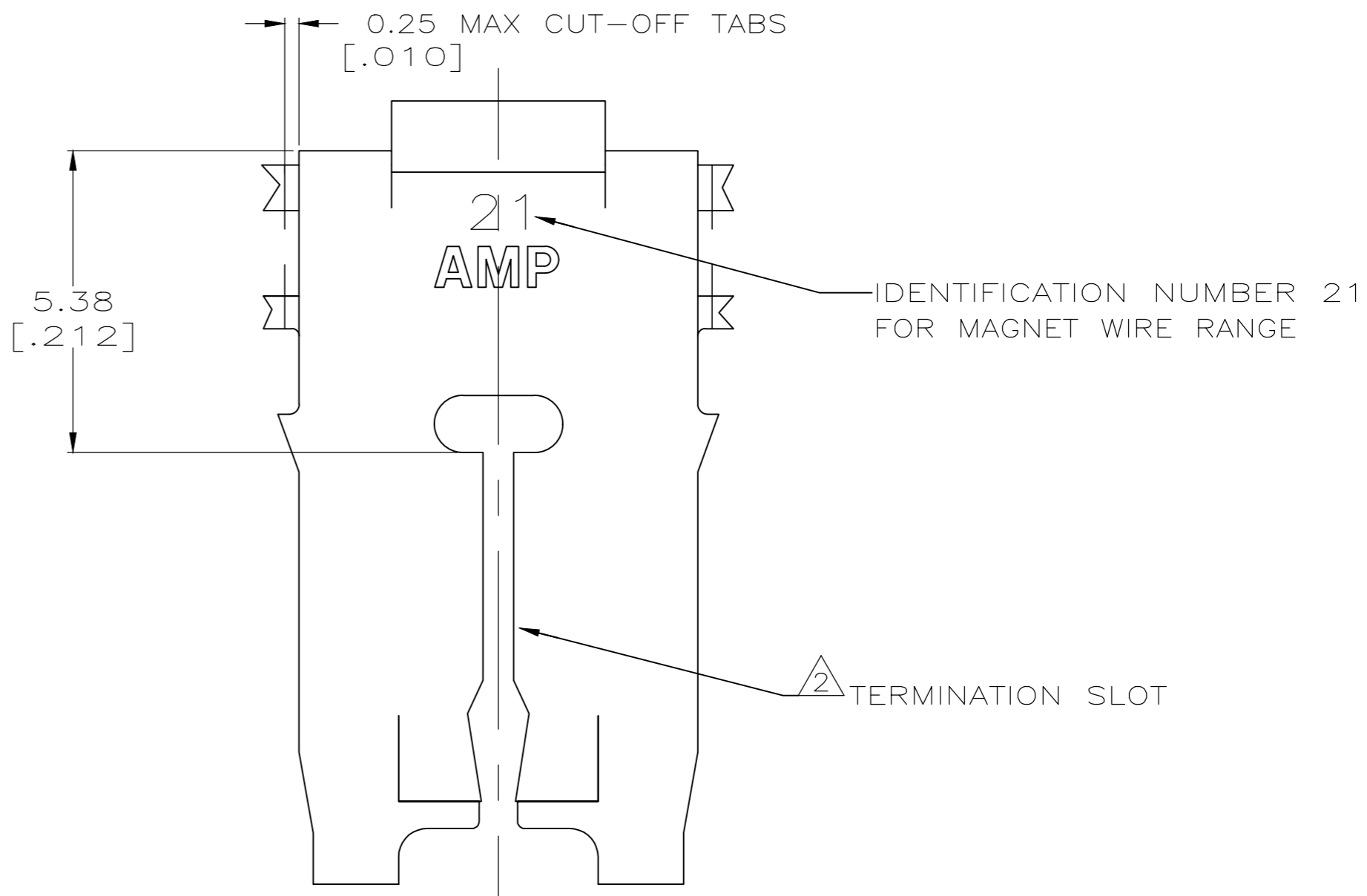
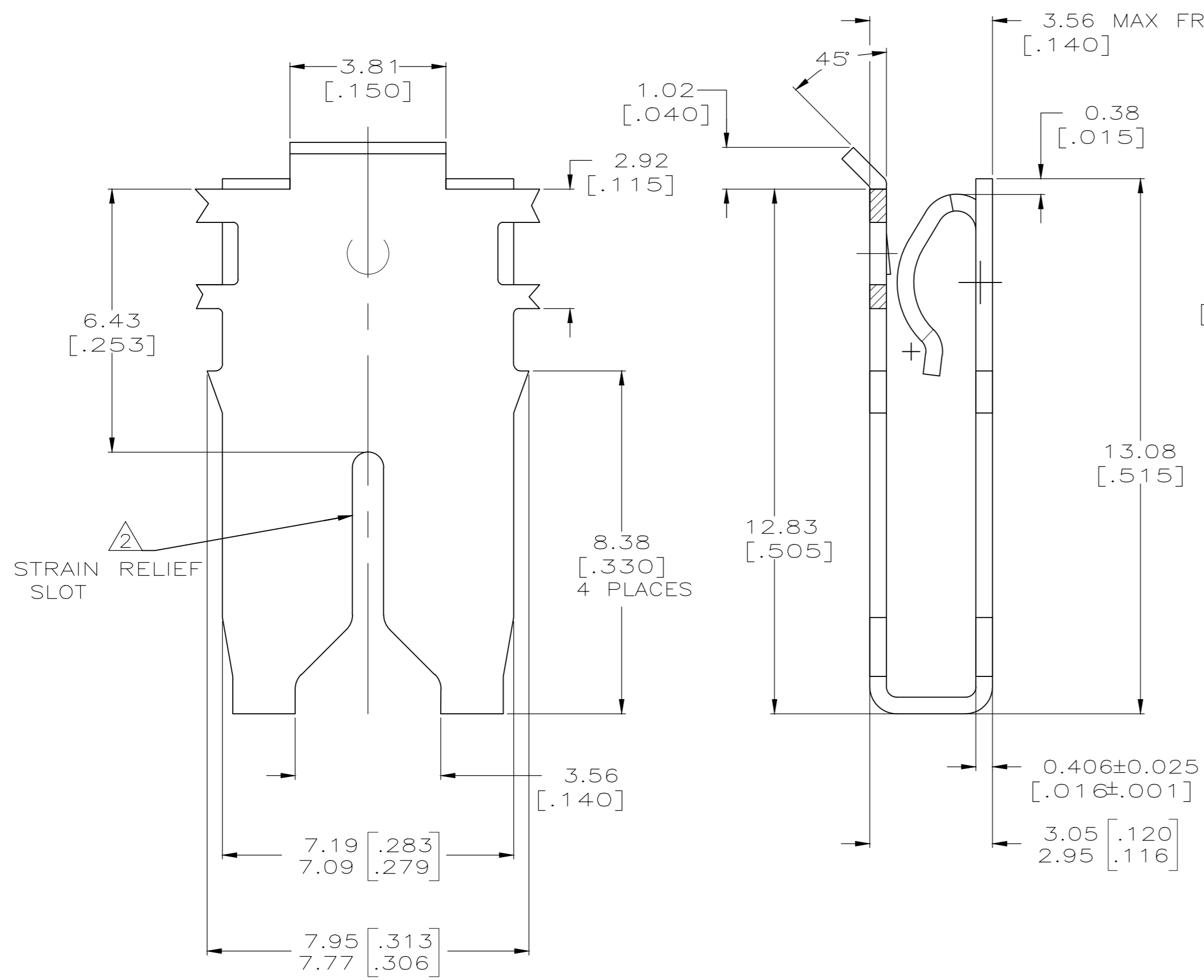

5	1217357-2
4	1217357-1
FINISH	PART NUMBER

THIS DRAWING IS A CONTROLLED DOCUMENT.		DWN	12FEB2007	MICHAEL S. FEHER	
DIMENSIONS:		CHK	12FEB2007	KURT A. RANDOLPH	
mm[INCHES]	TOLERANCES UNLESS OTHERWISE SPECIFIED:	APVD	12FEB2007	KURT A. RANDOLPH	
0 PLC ± -	1 PLC ± -	PRODUCT SPEC	108-2053	NAME	
2 PLC ± 0.25[.010]	3 PLC ± -	APPLICATION SPEC	114-2066	SPECIAL LEAF CONTACT, 500 SERIES MAG-MATE	
4 PLC ± -	ANGLES ± -	WEIGHT		SIZE	A2
MATERIAL	FINISH	CUSTOMER DRAWING		CAGE CODE	00779
BRASS	-			DRAWING NO	C=1217357
			SCALE	10:1	SHEET
					1 OF 1
			REV	E	

1217357