

THIS DRAWING IS UNPUBLISHED. RELEASED FOR PUBLICATION  
 © COPYRIGHT - By - TE CONNECTIVITY ALL RIGHTS RESERVED.

LOC	DIST	REVISIONS					
CM	OO	P	LTR	DESCRIPTION	DATE	DWN	APVD
		R		REVISED PER ECR-20-000814	26MAY2020	PC	SW

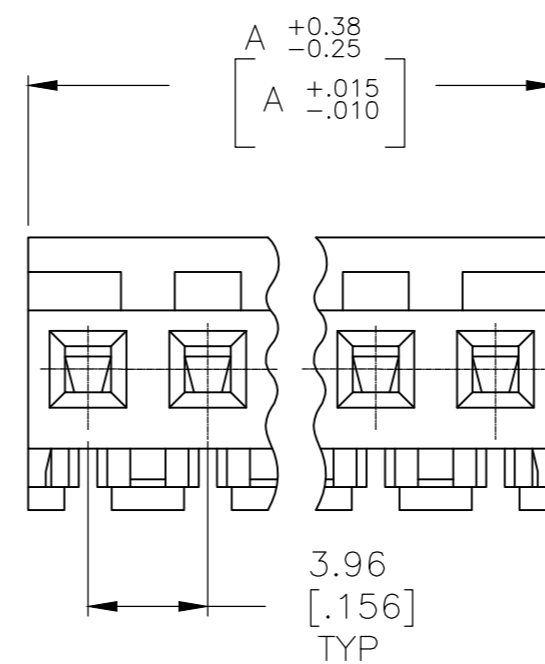
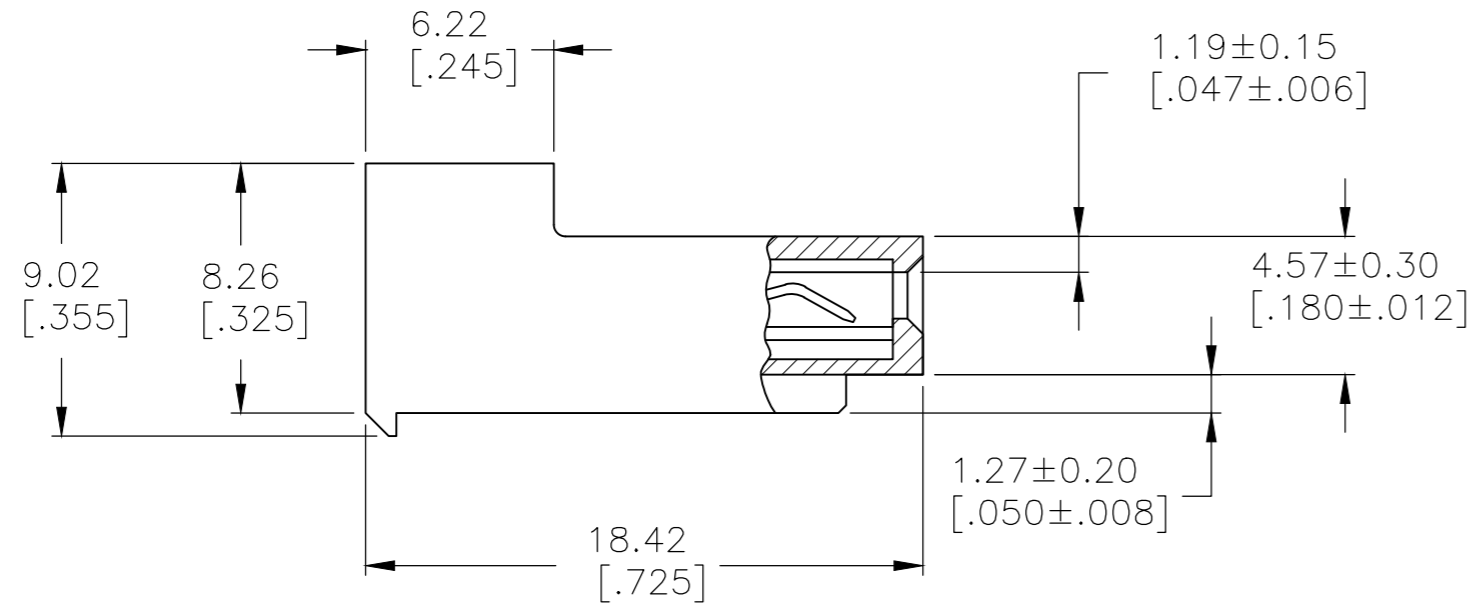
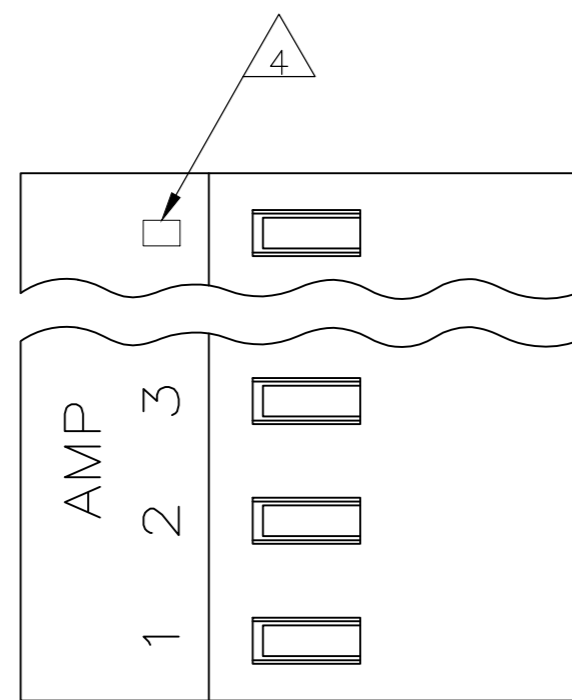

95.10[3.744]	24	5-640431-4
91.13[3.588]	23	5-640431-3
87.17[3.432]	22	5-640431-2
83.21[3.276]	21	5-640431-1
79.25[3.120]	20	5-640431-0
75.29[2.964]	19	4-640431-9
71.32[2.808]	18	4-640431-8
67.36[2.652]	17	4-640431-7
63.40[2.496]	16	4-640431-6
59.44[2.340]	15	4-640431-5
55.47[2.184]	14	4-640431-4
51.51[2.028]	13	4-640431-3
47.55[1.872]	12	4-640431-2
43.59[1.716]	11	4-640431-1
39.62[1.560]	10	4-640431-0
35.66[1.404]	9	3-640431-9
31.70[1.248]	8	3-640431-8
27.74[1.092]	7	3-640431-7
23.77[.936]	6	3-640431-6
19.81[.780]	5	3-640431-5
15.85[.624]	4	3-640431-4
11.89[.468]	3	3-640431-3
7.92[.312]	2	3-640431-2

1 MATERIAL: CONNECTOR - NYLON UL94-V2 (ORANGE).  
 CONTACTS - 0.30 [.012] THICK COPPER ALLOY  
 (BRIGHT TIN-LEAD 0.00203 [.000080] MIN. THICK  
 FOR CONTACTS 640431-2 THRU 2-640431-4).  
 (MATTE WHISKER MITIGATED TIN 0.00203 [.000080] MIN. THICK  
 FOR CONTACTS 3-640431-2 THRU 5-640431-4).

2 CONTACTS ACCEPT 18 AWG WIRE WITH 2.41 [.095] MAX INSULATION DIAMETER.

3 CONTACTS MUST ACCEPT 1.14±0.03 [.045±.001] POST AND REMAIN LOCKED IN POSITION.

4 IDENTIFICATION NUMBER FOR LAST CIRCUIT MAY NOT APPEAR ON ALL ASSEMBLIES.

5 DIMENSIONS IN BRACKETS ARE IN INCHES.

6 HOUSING FEATURES ARE: CLOSED END WITH LOCKING RAMP.

7 OBSOLETE PARTS: OBSOLETE CIS STREAMLINING PER D.RENAUD/D.SINISI

8 OBSOLETE PARTS

△	SUPERCEDED BY 5-640431-4	95.10[3.744]	24	2-640431-4
△	SUPERCEDED BY 5-640431-3	91.13[3.588]	23	2-640431-3
△	SUPERCEDED BY 5-640431-2	87.17[3.432]	22	2-640431-2
△	SUPERCEDED BY 5-640431-1	83.21[3.276]	21	2-640431-1
△	SUPERCEDED BY 5-640431-0	79.25[3.120]	20	2-640431-0
△	SUPERCEDED BY 4-640431-9	75.29[2.964]	19	1-640431-9
△	SUPERCEDED BY 4-640431-8	71.32[2.808]	18	1-640431-8
△	SUPERCEDED BY 4-640431-7	67.36[2.652]	17	1-640431-7
△	SUPERCEDED BY 4-640431-6	63.40[2.496]	16	1-640431-6
△	SUPERCEDED BY 4-640431-5	59.44[2.340]	15	1-640431-5
△	SUPERCEDED BY 4-640431-4	55.47[2.184]	14	1-640431-4
△	SUPERCEDED BY 4-640431-3	51.51[2.028]	13	1-640431-3
△	SUPERCEDED BY 4-640431-2	47.55[1.872]	12	1-640431-2
△	SUPERCEDED BY 4-640431-1	43.59[1.716]	11	1-640431-1
△	SUPERCEDED BY 4-640431-0	39.62[1.560]	10	1-640431-0
△	SUPERCEDED BY 3-640431-9	35.66[1.404]	9	640431-9
△	SUPERCEDED BY 3-640431-8	31.70[1.248]	8	640431-8
△	SUPERCEDED BY 3-640431-7	27.74[1.092]	7	640431-7
△	SUPERCEDED BY 3-640431-6	23.77[.936]	6	640431-6
△	SUPERCEDED BY 3-640431-5	19.81[.780]	5	640431-5
△	SUPERCEDED BY 3-640431-4	15.85[.624]	4	640431-4
△	SUPERCEDED BY 3-640431-3	11.89[.468]	3	640431-3
△	SUPERCEDED BY 3-640431-2	7.92[.312]	2	640431-2

THIS DRAWING IS A CONTROLLED DOCUMENT.		DWN S. CARPENTER 09JUL2003		
DIMENSIONS: mm [INCHES]		CHK D. BOSSI 09JUL2003		
TOLERANCES UNLESS OTHERWISE SPECIFIED:		APVD D. BOSSI 09JUL2003	NAME	
0 PLC ± -		PRODUCT SPEC		MTA 156 CONNECTOR ASSEMBLY, 18 AWG, STANDARD
1 PLC ± -		108-1051		
2 PLC ± -		APPLICATION SPEC		SIZE
3 PLC ± 0.13 [.005]		114-1020		CAGE CODE
4 PLC ± -		WEIGHT		DRAWING NO
ANGLES ± -		CUSTOMER DRAWING		RESTRICTED TO
FINISH		SCALE 4:1		SHEET 1 OF 1
1		REV R		