

SN54ALS756, SN54AS756, SN54AS757 SN74ALS756, SN74AS756, SN74AS757

OCTAL BUFFERS AND LINE DRIVERS WITH OPEN-COLLECTOR OUTPUTS

D2661, DECEMBER 1983—REVISED MAY 1986

- Open-Collector Outputs Drive Bus Lines or Buffer Memory Address Registers
- Eliminates the Need for 3-State Overlap Protection
- P-N-P Inputs Reduce DC Loading
- Package Options Include Plastic "Small Outline" Packages, Ceramic Chip Carriers, and Standard Plastic and Ceramic 300-mil DIPs
- Open-Collector Versions of 'ALS240A, 'ALS241A, and 'AS240, 'AS241
- Dependable Texas Instruments Quality and Reliability

description

These octal buffers and line drivers are designed specifically to improve both the performance and density of three-state memory address drivers, clock drivers, and bus-oriented receivers and transmitters by eliminating the need for three-state overlap protection. The designer has a choice of selected combinations of inverting and noninverting outputs, symmetrical \bar{G} (active-low output control) inputs, and complementary G and \bar{G} inputs. These devices feature high fan-out and improved fan-in.

The -1 version of the SN74ALS756 is identical to the standard version except that the recommended maximum I_{OL} is increased to 48 milliamperes. There is no -1 version of the SN54ALS756.

The SN54' family is characterized for operation over the full military temperature range of -55°C to 125°C . The SN74' family is characterized for operation from 0°C to 70°C .

SN54ALS', SN54AS' ... J PACKAGE
SN74ALS', SN74AS' ... DW OR N PACKAGE

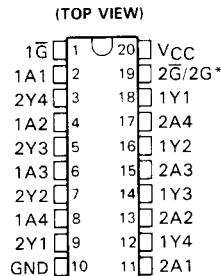

SN54ALS', SN54AS' ... FK PACKAGE

(TOP VIEW)

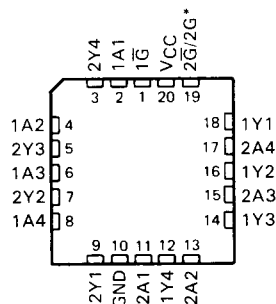

*2 \bar{G} for 'ALS756, 'AS756 or 2G for 'AS757.

2

ALS and AS Circuits

PRODUCTION DATA documents contain information current as of publication date. Products conform to specifications per the terms of Texas Instruments standard warranty. Production processing does not necessarily include testing of all parameters.

**TEXAS
INSTRUMENTS**

POST OFFICE BOX 655012 • DALLAS, TEXAS 75265

Copyright © 1983, Texas Instruments Incorporated

2-589

**SN54ALS756, SN54AS756, SN54AS757
SN74ALS756, SN74AS756, SN74AS757
OCTAL BUFFERS AND LINE DRIVERS WITH OPEN-COLLECTOR OUTPUTS**

logic symbols†

2

ALS and AS Circuits

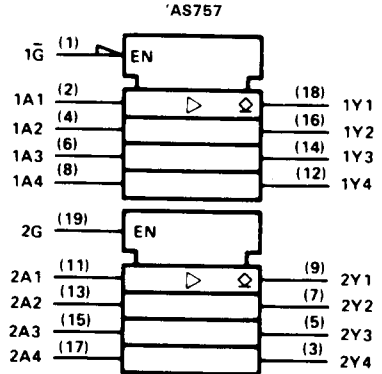
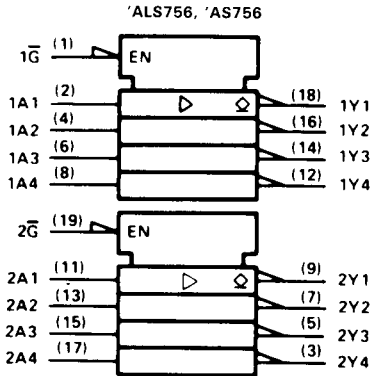

†These symbols are in accordance with ANSI/IEEE Std 91-1984 and IEC Publication 617-12.

logic diagrams (positive logic)

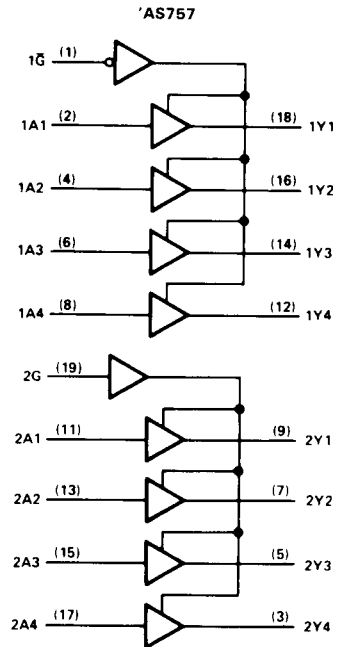
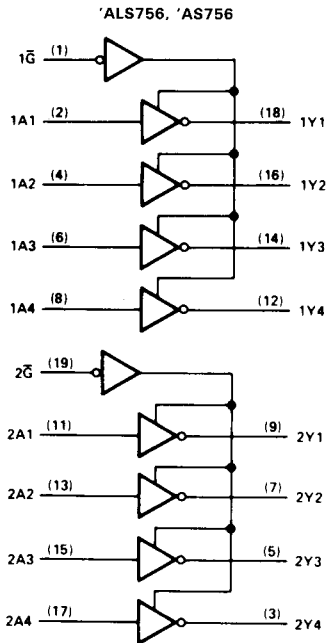

SN54ALS756, SN74ALS756

OCTAL BUFFERS AND LINE DRIVERS WITH OPEN-COLLECTOR OUTPUTS

absolute maximum ratings over operating free-air temperature range (unless otherwise noted)

Supply voltage, V_{CC}	7 V
Input voltage	7 V
Off-state output voltage	7 V
Operating free-air temperature range: SN54ALS756	-55°C to 125°C
SN74ALS756	0°C to 70°C
Storage temperature range	-65°C to 150°C

recommended operating conditions

	SN54ALS756			SN74ALS756			UNIT
	MIN	NOM	MAX	MIN	NOM	MAX	
V_{CC} Supply voltage	4.5	5	5.5	4.5	5	5.5	V
V_{IH} High-level input voltage	2			2			V
V_{IL} Low-level input voltage			0.7			0.8	V
V_{OH} High-level output voltage			5.5			5.5	V
I_{OL} Low-level output current			12			24	mA
						48†	
T_A Operating free-air temperature	-55		125	0		70	°C

† The 48-mA limit applies only to the -1 versions and only if V_{CC} is maintained between 4.75 V and 5.25 V.

electrical characteristics over recommended operating free-air temperature range (unless otherwise noted)

PARAMETER	TEST CONDITIONS	SN54ALS756			SN74ALS756			UNIT
		MIN	TYP‡	MAX	MIN	TYP‡	MAX	
V_{IK}	$V_{CC} = 4.5$ V, $I_I = -18$ mA			-1.5			-1.5	V
I_{OH}	$V_{CC} = 4.5$ V, $V_{OH} = 5.5$ V			0.1			0.1	mA
V_{OL}	$V_{CC} = 4.5$ V, $I_{OL} = 12$ mA		0.25	0.4		0.25	0.4	V
	$V_{CC} = 4.5$ V, $I_{OL} = 24$ mA§					0.35	0.5	
I_I	$V_{CC} = 5.5$ V, $V_I = 7$ V			0.1			0.1	mA
I_{IH}	$V_{CC} = 5.5$ V, $V_I = 2.7$ V			20			20	µA
I_{IL}	$V_{CC} = 5.5$ V, $V_I = 0.4$ V			-0.1			-0.1	mA
I_{CC}	$V_{CC} = 5.5$ V	Output high	7	11	7	11	mA	
		Output low	13	22	13	22		

‡ All typical values are at $V_{CC} = 5$ V, $T_A = 25$ °C.

§ $V_{CC} = 4.75$ V and $I_{OL} = 48$ mA for -1 versions.

switching characteristics (see Note 1)

PARAMETER	FROM (INPUT)	TO (OUTPUT)	$V_{CC} = 5$ V, $C_L = 50$ pF, $R_L = 500$ Ω, $T_A = 25$ °C		$V_{CC} = 4.5$ V to 5.5 V, $C_L = 50$ pF, $R_L = 500$ Ω, $T_A = \text{MIN to MAX}$				UNIT
			ALS756		SN54ALS756		SN74ALS756		
			TYP	MIN	MAX	MIN	MAX		
t_{PLH}	A	Y	14	8	29	8	24	ns	
t_{PHL}			5	2	12	2	10		
t_{PLH}	\bar{G}	Y	16	8	29	8	24	ns	
t_{PHL}			12	6	23	6	20		

NOTE 1: Load circuit and voltage waveforms are shown in Section 1.



2
ALS and AS Circuits

SN54AS756, SN54AS757, SN74AS756, SN74AS757

OCTAL BUFFERS AND LINE DRIVERS WITH OPEN-COLLECTOR OUTPUTS

absolute maximum ratings over operating free-air temperature range (unless otherwise noted)

Supply voltage, V_{CC}	7 V
Input voltage	7 V
Off-state output voltage	7 V
Operating free-air temperature range: SN54AS756, SN54AS757	-55°C to 125°C
SN74AS756, SN74AS757	0°C to 70°C
Storage temperature range	-65°C to 150°C

recommended operating conditions

	SN54AS756 SN54AS757			SN74AS756 SN74AS757			UNIT
	MIN	NOM	MAX	MIN	NOM	MAX	
V_{CC} Supply voltage	4.5	5	5.5	4.5	5	5.5	V
V_{IH} High-level input voltage	2			2			V
V_{IL} Low-level input voltage			0.8			0.8	V
V_{OH} High-level output voltage			5.5			5.5	V
I_{OL} Low-level output current			48			64	mA
T_A Operating free-air temperature	-55		125	0		70	°C

electrical characteristics over recommended operating free-air temperature range (unless otherwise noted)

PARAMETER	TEST CONDITIONS	SN54AS756 SN54AS757		SN74AS756 SN74AS757		UNIT		
		MIN	TYP†	MAX	MIN		TYP†	MAX
V_{IK}	$V_{CC} = 4.5$ V, $I_I = -18$ mA			-1.2		-1.2	V	
I_{OH}	$V_{CC} = 4.5$ V, $V_{OH} = 5.5$ V			0.1		0.1	mA	
V_{OL}	$V_{CC} = 4.5$ V, $I_{OL} = 48$ mA		0.55				V	
	$V_{CC} = 4.5$ V, $I_{OL} = 64$ mA					0.55		
I_I	$V_{CC} = 5.5$ V, $V_I = 7$ V			0.1		0.1	mA	
I_{IH}	$V_{CC} = 5.5$ V, $V_I = 2.7$ V			20		20	μA	
I_{IL}	$V_{CC} = 5.5$ V, $V_I = 0.4$ V	A inputs of 'AS757 only				-1	mA	
		All other inputs				-0.5		
I_{CC}	$V_{CC} = 5.5$ V,		Output high		9	15	9	mA
			Output low		51	80	51	
			Output high		21	33	21	
			Output low		61	95	61	

† All typical values are at $V_{CC} = 5$ V, $T_A = 25$ °C.

2

ALS and AS Circuits

SN54AS756, SN54AS757, SN74AS756, SN74AS757
OCTAL BUFFERS AND LINE DRIVERS WITH OPEN-COLLECTOR OUTPUTS

'AS756 switching characteristics (see Note 1)

PARAMETER	FROM (INPUT)	TO (OUTPUT)	$V_{CC} = 4.5 \text{ V to } 5.5 \text{ V,}$ $C_L = 50 \text{ pF,}$ $R_L = 500 \Omega,$ $T_A = \text{MIN to MAX}$				UNIT
			SN54AS756		SN74AS756		
			MIN	MAX	MIN	MAX	
t_{PLH}	A	Y	3	20	3	19	ns
t_{PHL}			1	7	1	6	
t_{PLH}	\bar{G}	Y	3	22	3	19.5	ns
t_{PHL}			1	8.5	1	7.5	

'AS757 switching characteristics (see Note 1)

PARAMETER	FROM (INPUT)	TO (OUTPUT)	$V_{CC} = 4.5 \text{ V to } 5.5 \text{ V,}$ $C_L = 50 \text{ pF,}$ $R_L = 500 \Omega,$ $T_A = \text{MIN to MAX}$				UNIT
			SN54AS757		SN74AS757		
			MIN	MAX	MIN	MAX	
t_{PLH}	A	Y	3	19.5	3	18.5	ns
t_{PHL}			1	7	1	6	
t_{PLH}	$1\bar{G}$	Y	3	21	3	20	ns
t_{PHL}			1	8	1	7	
t_{PLH}	2G	Y	3	22.5	3	21	ns
t_{PHL}			1	8.5	1	7.5	

NOTE 1: Load circuit and voltage waveforms are shown in Section 1.

2

ALS and AS Circuits