

10120132 - X0E - XXXLF

LEAD-FREE DESIGNATION ONLY WITH APPLICABLE PLATING CODES

LETTER	PLATING (SEE NOTE 6)	
	APPLICATION	TYPE (REFERENCE)
B	TELCORDIA CO	0.76µm GOLD or GXT
C	TELCORDIA UE	1.27µm GOLD
D	TELCORDIA CO	0.76µm GOLD or GXT, LEAD-FREE
E	TELCORDIA UE	1.27µm GOLD, LEAD-FREE

8-COLUMN DIFFERENTIAL SIGNAL

NUMBER	GUIDE PIN STYLE (SEE NOTE 8)
0	STANDARD GUIDE PIN, MACHINED
1	STANDARD GUIDE PIN, ROLLED

MODULE DESCRIPTION	LETTER DESIGNATION REPRESENTED IN DASH NUMBER										BASE MODULE
LEFT POLARIZING GUIDANCE MODULE (SEE SHEET 6)	N	J	A	B	C	D	E	F	G	H	
	NO KEY NO GUIDE PIN										
RIGHT POLARIZING GUIDANCE MODULE (SEE SHEET 7)	Z	Y	P	Q	R	S	T	U	V	W	
	NO KEY NO GUIDE PIN										
OPEN MODULE (TWO WALL) (SEE SHEET 2)	0 (ZERO)										
LEFT WALL MODULE (SEE SHEET 3)	L										
RIGHT WALL MODULE (SEE SHEET 4)	M										
FOUR WALL MODULE (SEE SHEET 5)	I (ONE)										

NUMBER	CONTACT MATING WIPE LENGTH		COMPLIANT TAIL TYPE (SEE NOTE 9)
	SIGNAL	GROUND	
1	2 MM	4 MM	0.55 (0.0217" DRILL)
2	3 MM	4 MM	0.55 (0.0217" DRILL)
3	2 MM	4 MM	0.45 MICRO (0.0177" DRILL)
4	3 MM	4 MM	0.45 MICRO (0.0177" DRILL)
5	2 MM	3 MM	0.55 (0.0217" DRILL)
6	3 MM	3 MM	0.55 (0.0217" DRILL)
7	2 MM	3 MM	0.45 MICRO (0.0177" DRILL)
8	3 MM	3 MM	0.45 MICRO (0.0177" DRILL)

FOR CUSTOM-LOADED MODULES, SEE INDIVIDUAL CUSTOM DRAWINGS WITH THE DRAWING-NUMBER FORMAT OF 10120132-XXXX, WHERE: "X" DENOTES MODULE TYPE PER CHART ON THIS SHEET "YYYY" IS A SEQUENTIAL NUMBER BEGINNING WITH "0001".

	UNGROUND	GROUND
FHS	∅2.35-∅2.55	∅2.35-∅2.55
PAD	N/A	∅5.50
PLATED	NO	YES
DRILL(mm)	2.44mm	2.58mm
DRILL(in)	0.096"	0.1015"

SCREW P/N	DESCRIPTION	BOARD THICKNESS
10091790-002LF	#2-56 X 0.375" LG. PHILIPS PANHEAD W/SQ CONICAL WASHER	1.60-5.00mm
10091790-003LF	#2-56 X 0.375" LG. PHILIPS PANHEAD W/SQ CONICAL WASHER	5.00-10.00mm

spec ref	-	dr	Yong-Keat Lim	2012/02/23	projection	MM	size	A2	scale	2:1
tolerance std	ASME Y14.5	eng	Sandar Soe	2016/03/08	chr	-	ecn no	ELX-S-17624-1	rel level	Released
surface	linear	app'r	Chen-Hong Tan	2016/03/17	product family	XCEDE HD	cat. no.	10120132	rev	C
ASME Y14.5	angular									

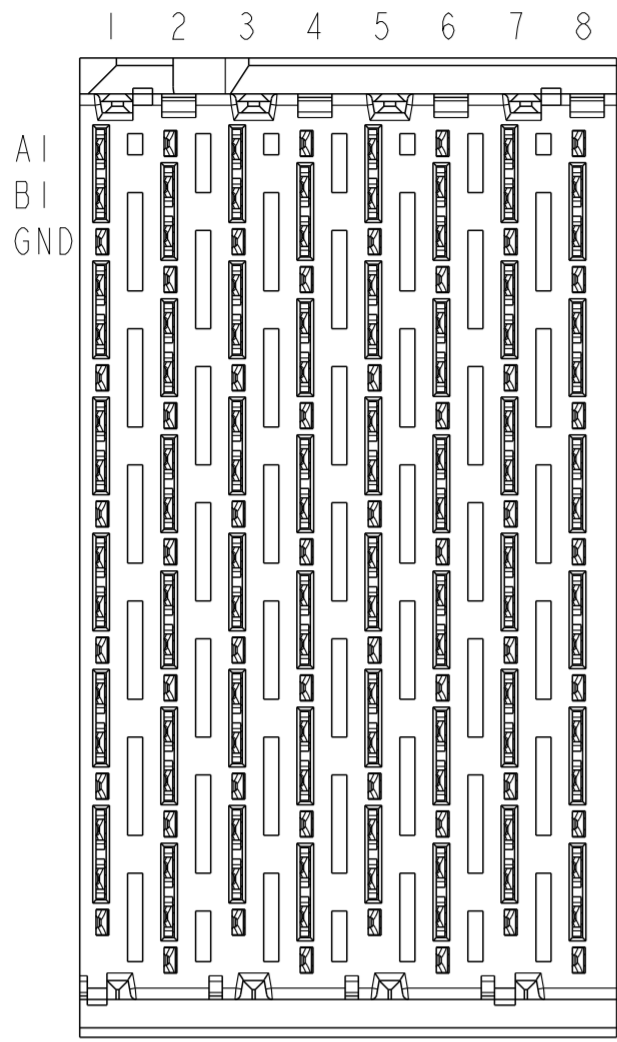

OPEN WALL MODULE

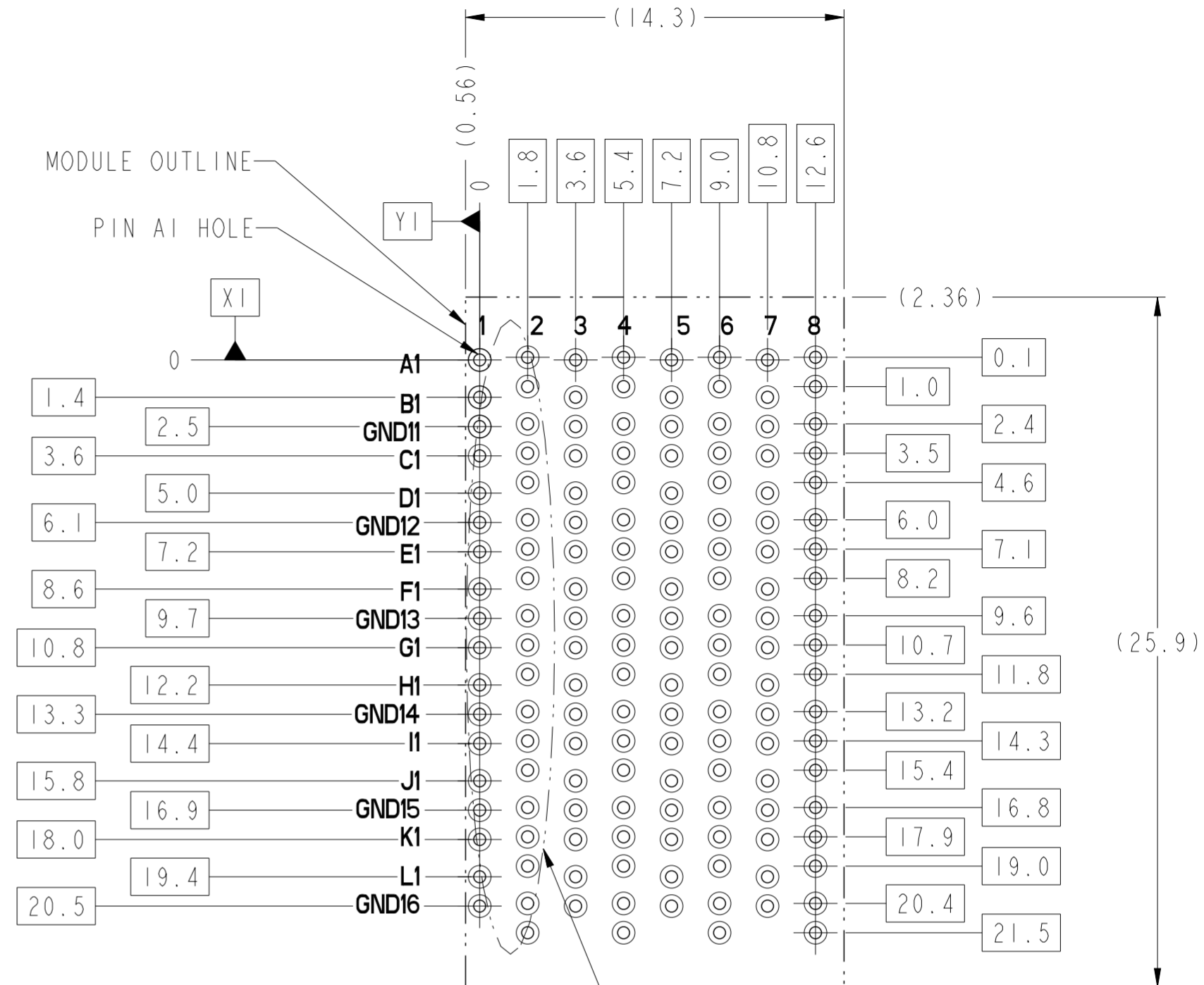
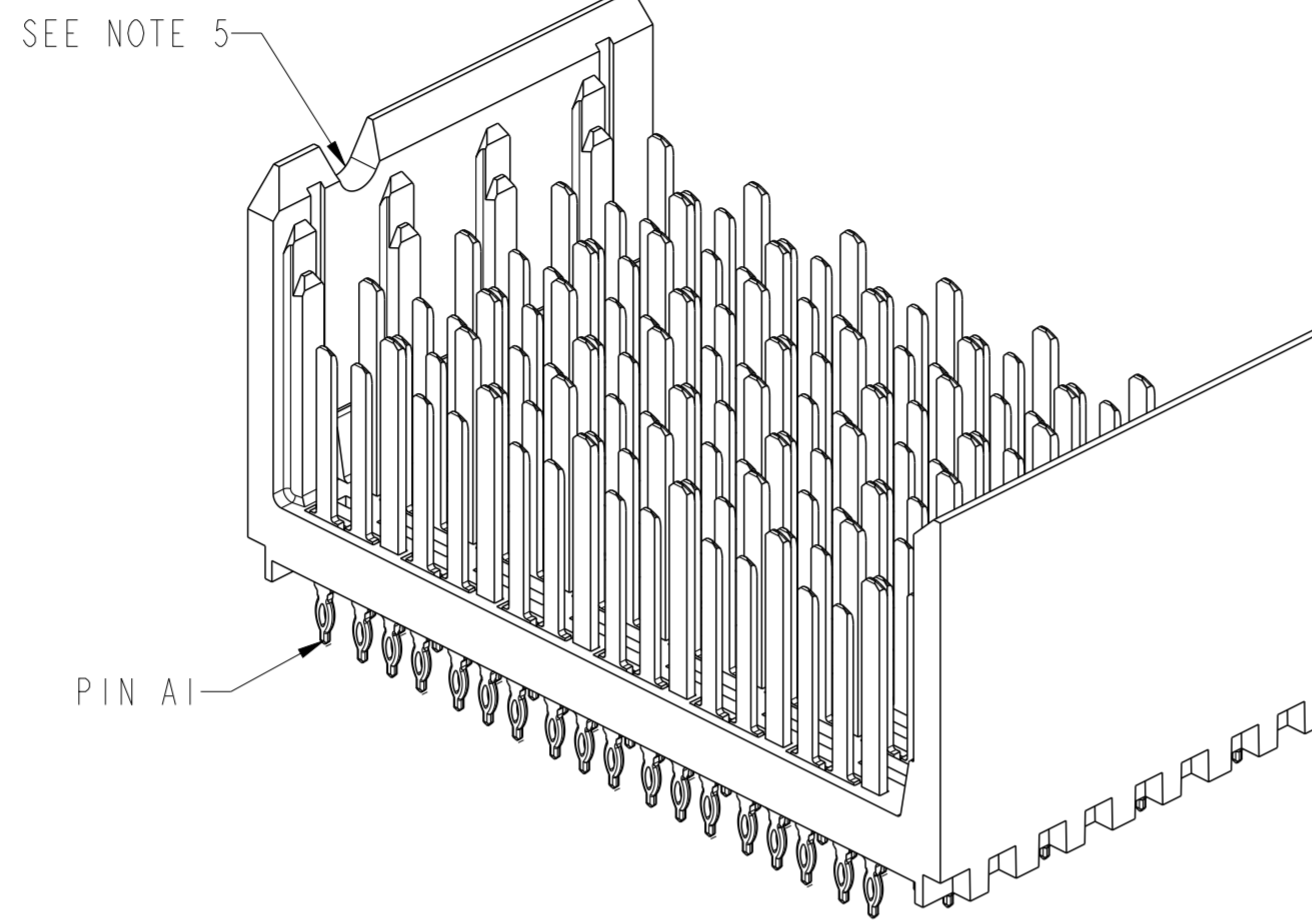

SEE DETAIL A ON SHEET 8 FOR PINOUT DETAILS  
BP HOLE PATTERN COMPONENT SIDE

OPEN WALL MODULE BACKPLANE FOOTPRINT

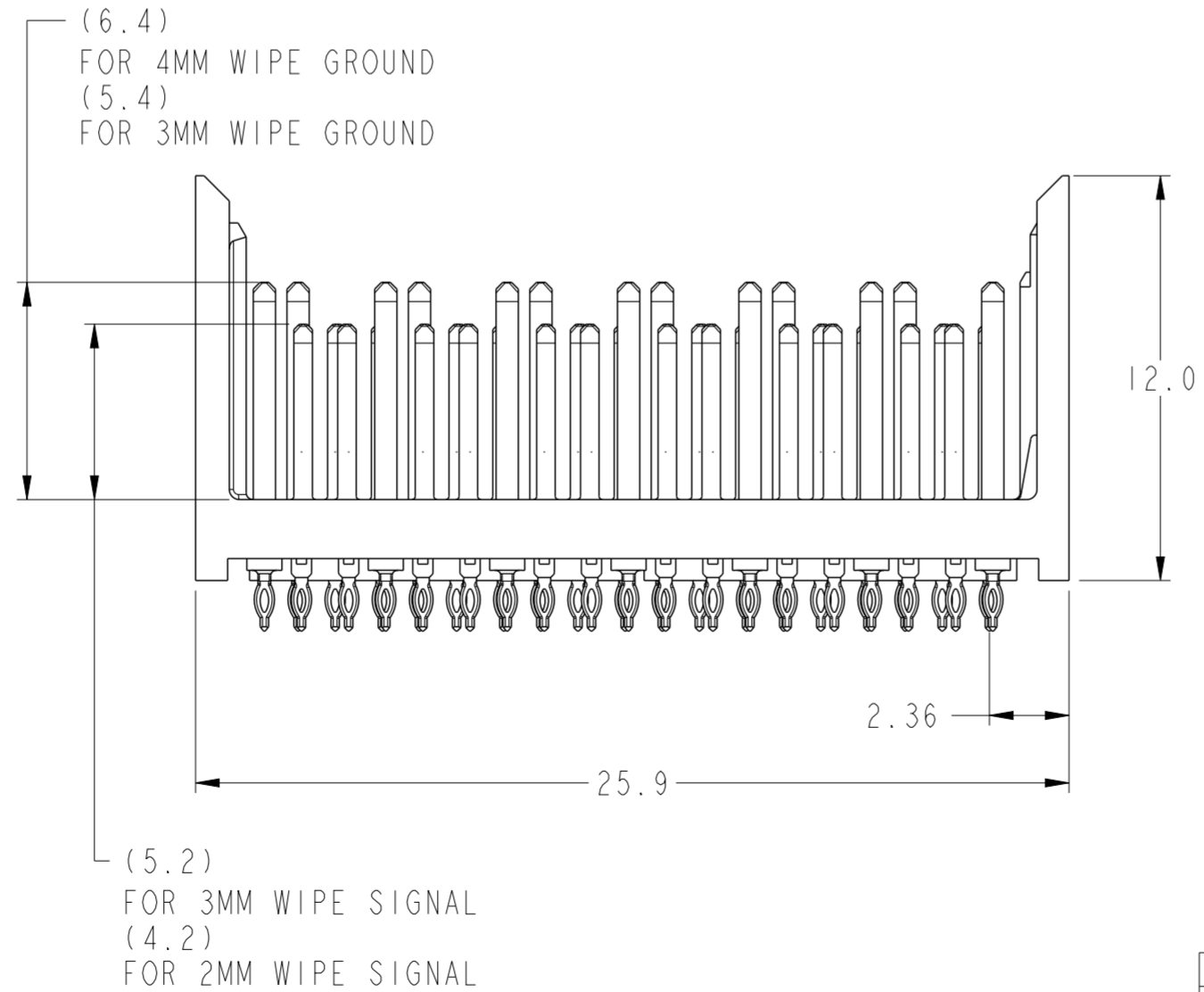
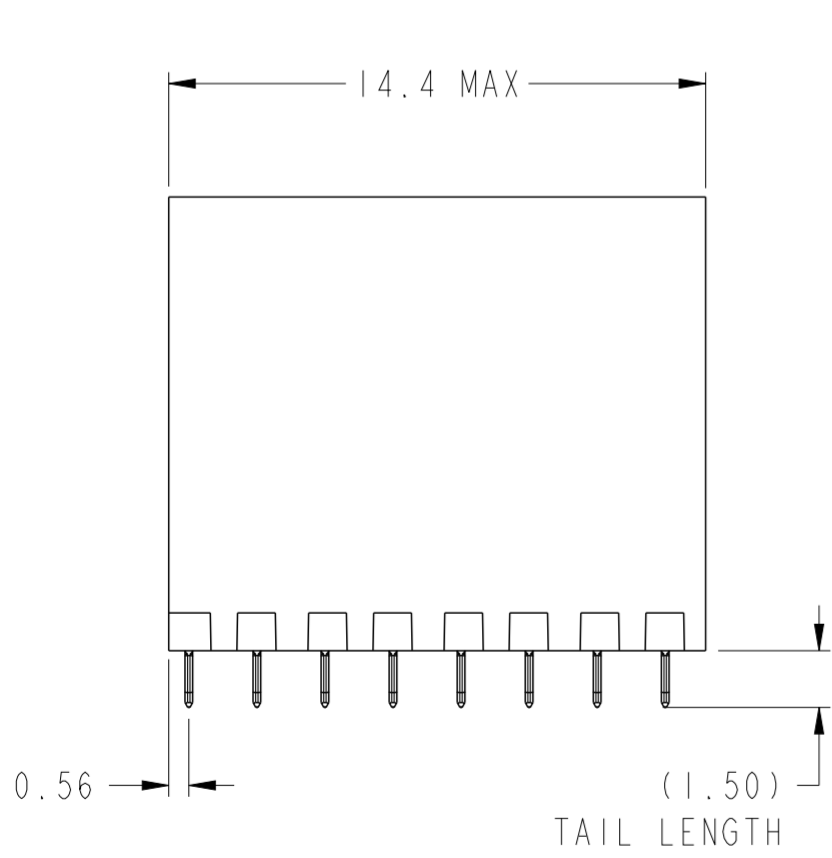

spec ref	-	dr	Yong-Keat Lim	2012/02/23	projection	MM	size	A2	scale	5:1
tolerance std	ASME Y14.5	eng	Sandar Soe	2016/03/08			ecn no	ELX-S-17624-1		
TOLERANCES UNLESS OTHERWISE SPECIFIED		chr	-	rel level			Released			
surface	linear	0.X	±0.3		product family	XCEDE HD	rel level	Released		
ASME Y14.5	angular	0°	±2°		cat. no.	-	Product - Customer Drw	sheet 2 of 8		
	angular	0°	±2°		www.fci.com	-	Product - Customer Drw	sheet 2 of 8		
TITLES		VERTICAL HEADER ASSEMBLY		cat. no.	-	Product - Customer Drw	sheet 2 of 8			
TITLES		XCEDE HD 6 PAIR, 8 COLUMN		cat. no.	-	Product - Customer Drw	sheet 2 of 8			
TITLES		10120132		cat. no.	-	Product - Customer Drw	sheet 2 of 8			
TITLES		C		cat. no.	-	Product - Customer Drw	sheet 2 of 8			

Amphenol FCI

© 2016 APCI

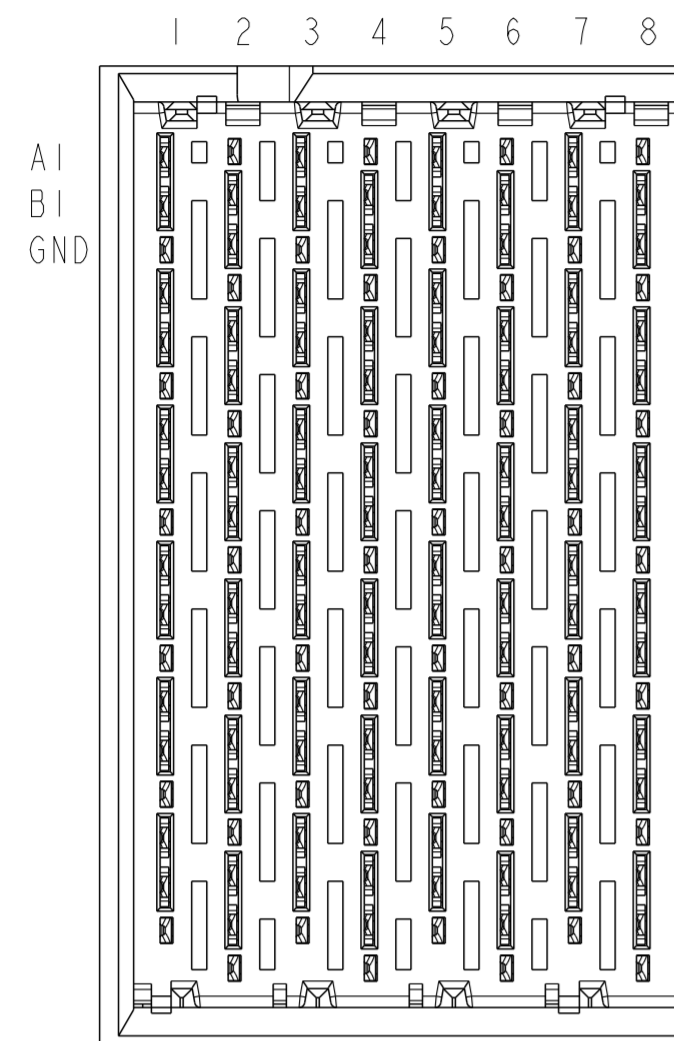

LEFT WALL MODULE

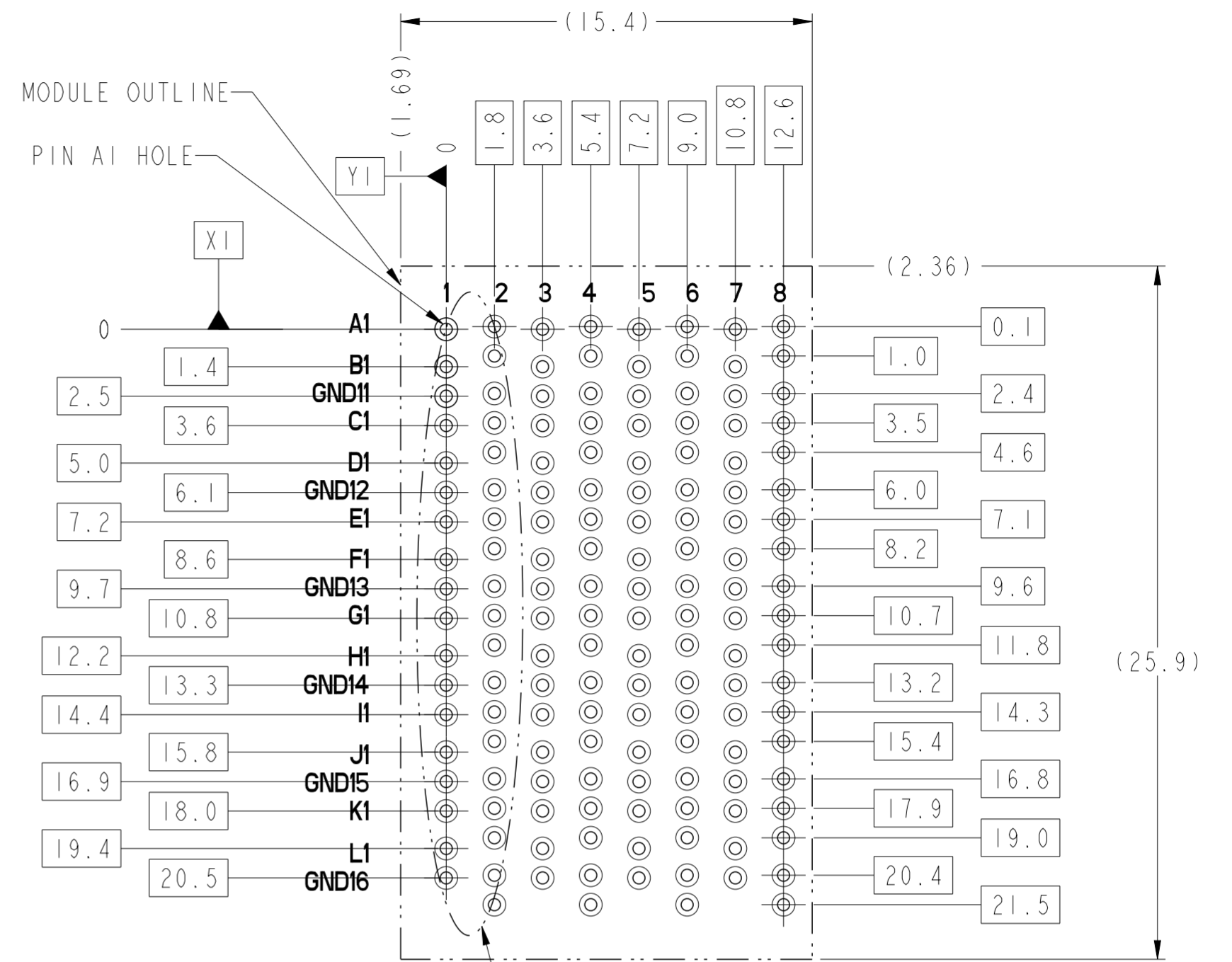
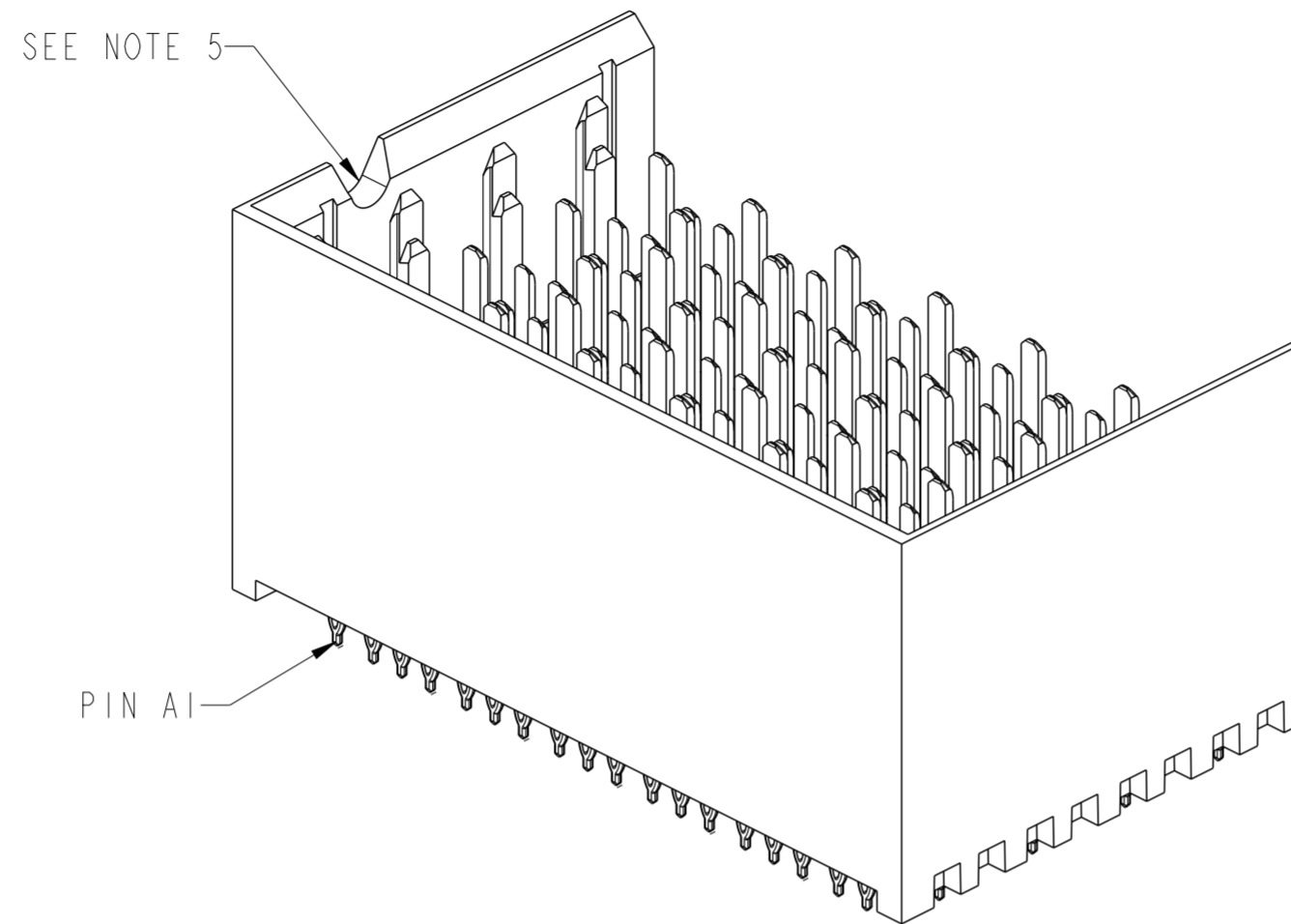

SEE DETAIL A ON SHEET 8 FOR PINOUT DETAILS

BP HOLE PATTERN COMPONENT SIDE

LEFT WALL MODULE BACKPLANE FOOTPRINT

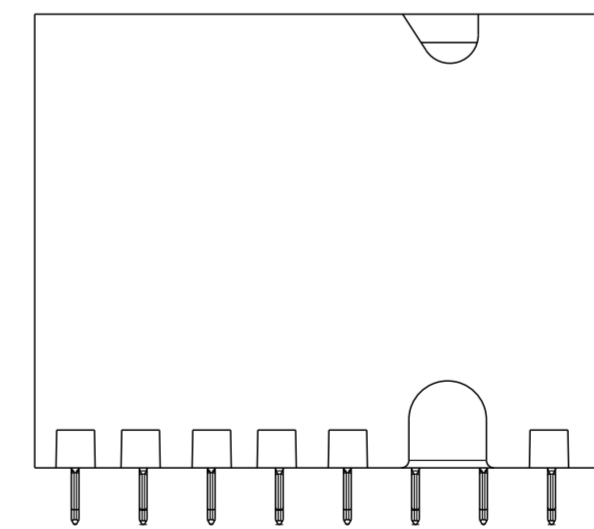
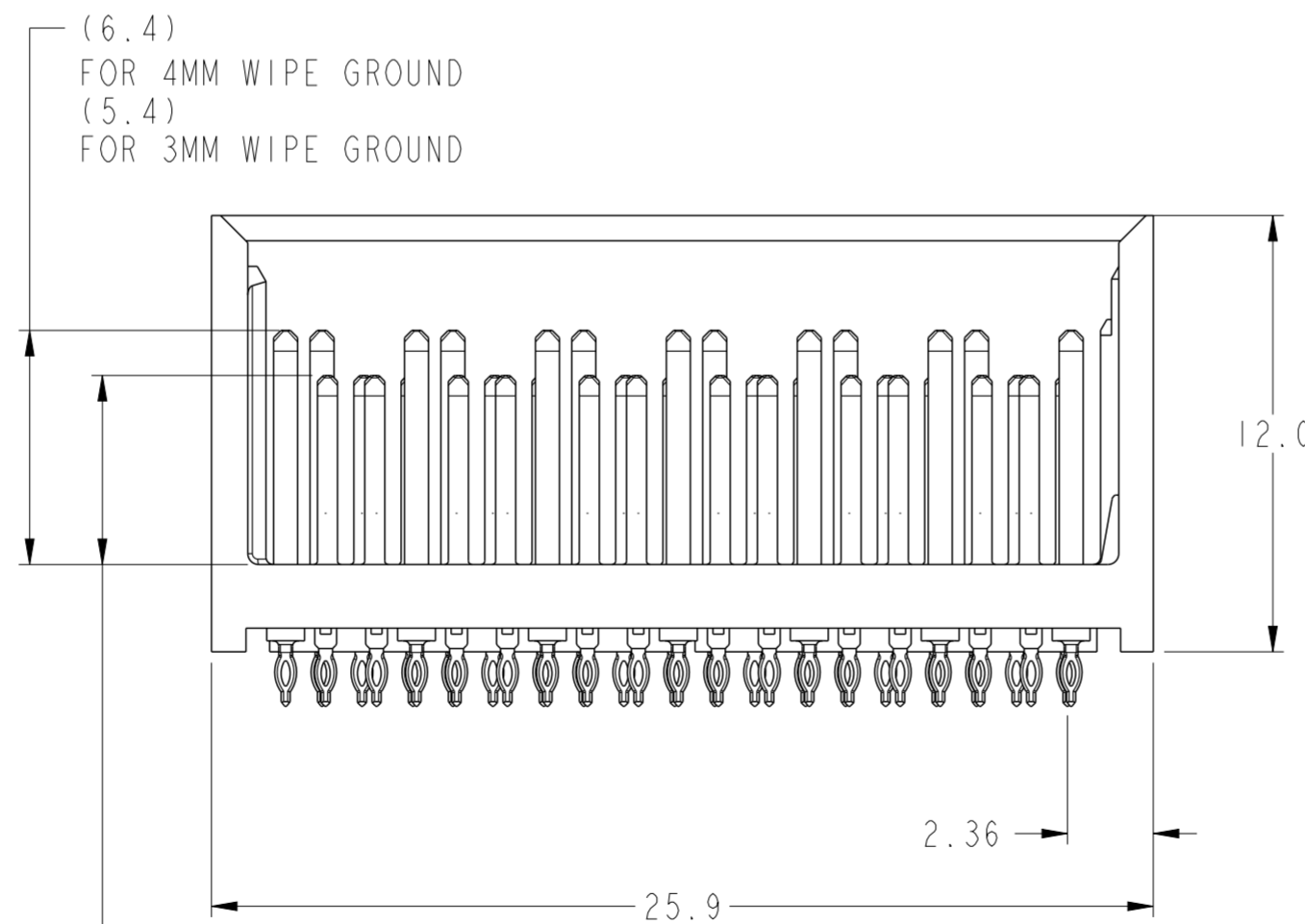
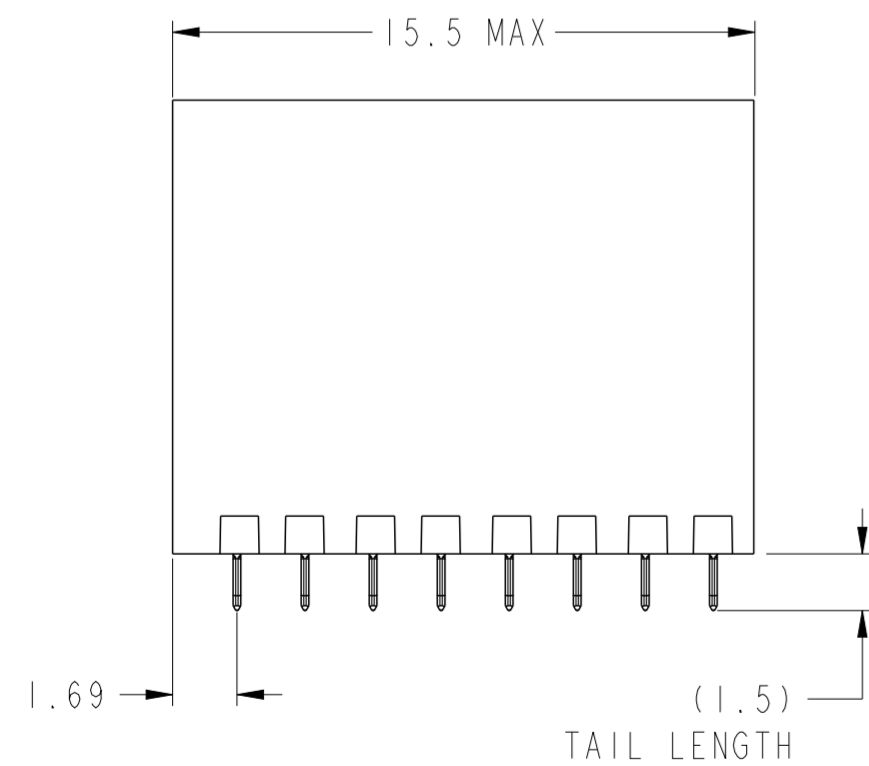

spec ref	-	dr	Yong-Keat Lim	2012/02/23	projection	MM	size	A2	scale	5:1
tolerance std	ASME Y14.5	eng	Sandar Soe	2016/03/08	chr	-	ecn no	ELX-S-17624-1	rel level	Released
surface	ASME Y14.5	appr	Chen-Hong Tan	2016/03/17	product family	XCEDE HD	rel level	Released	cat. no.	Product - Customer Drw
linear	0.X ±0.3 0.XX ±0.10 0.XXX ±0.05	angular	0° ±2°	Amphenol FCI	www.fci.com	VERTICAL HEADER ASSEMBLY XCEDE HD 6 PAIR, 8 COLUMN	dwg no	10120132	rev	C



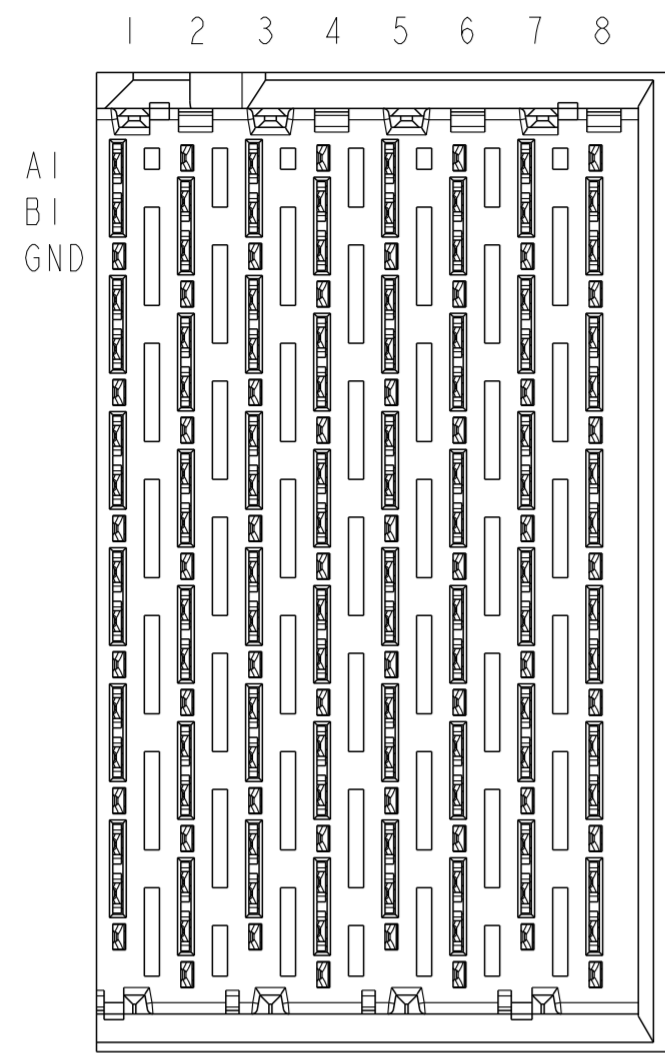

RIGHT WALL MODULE

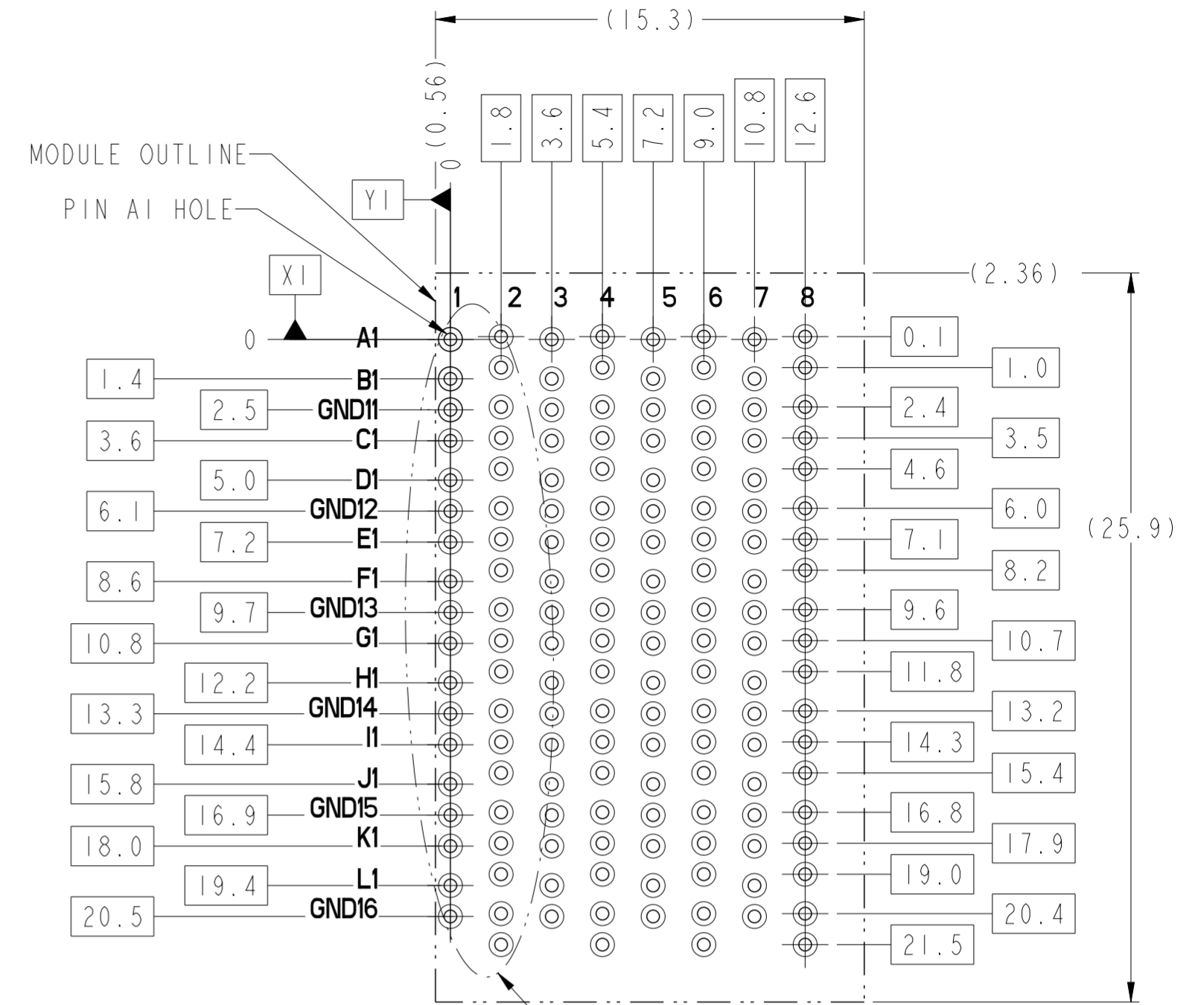
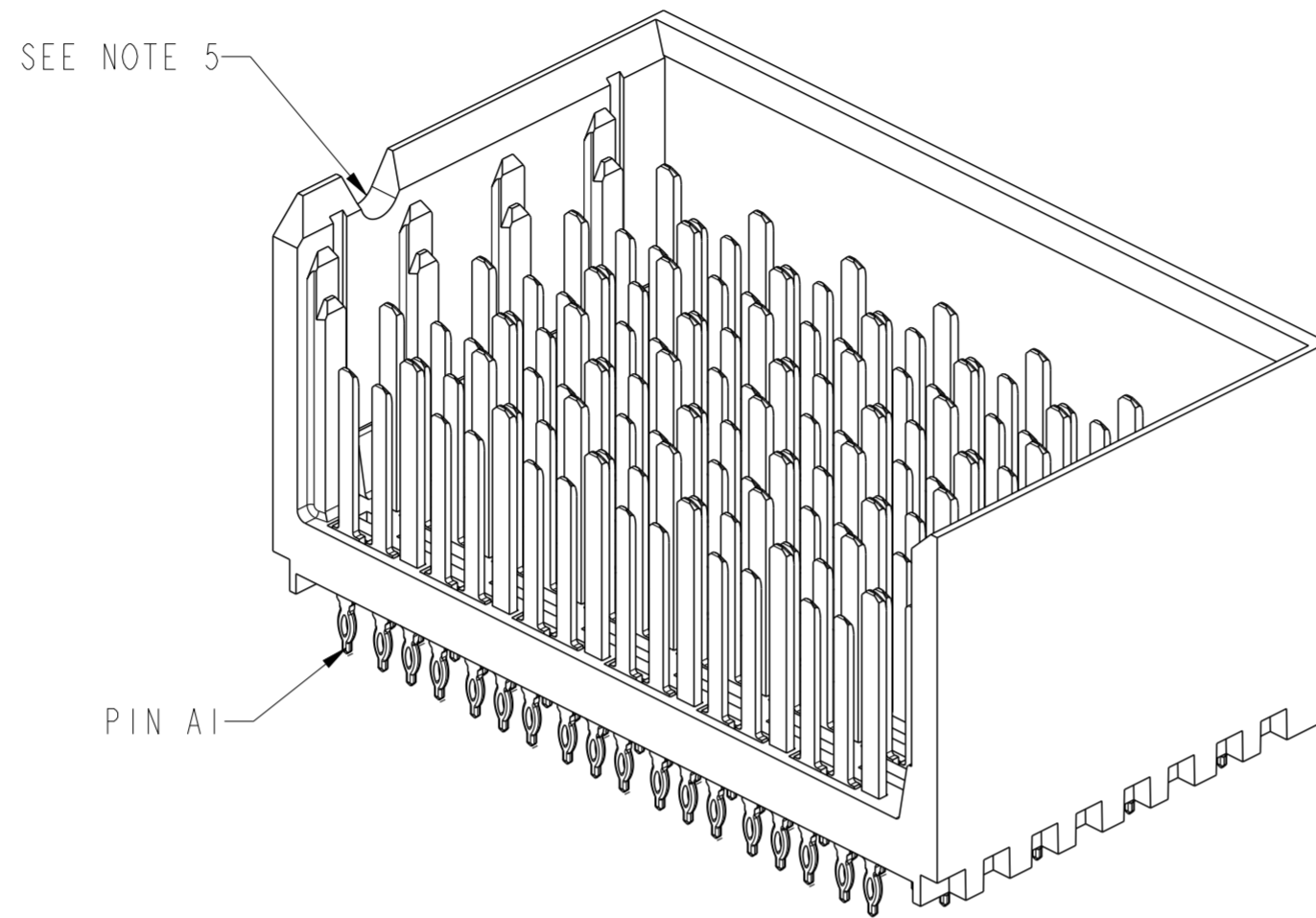

SEE DETAIL A  
ON SHEET 8 FOR PINOUT DETAILS

BP HOLE PATTERN COMPONENT SIDE

RIGHT WALL MODULE BACKPLANE FOOTPRINT

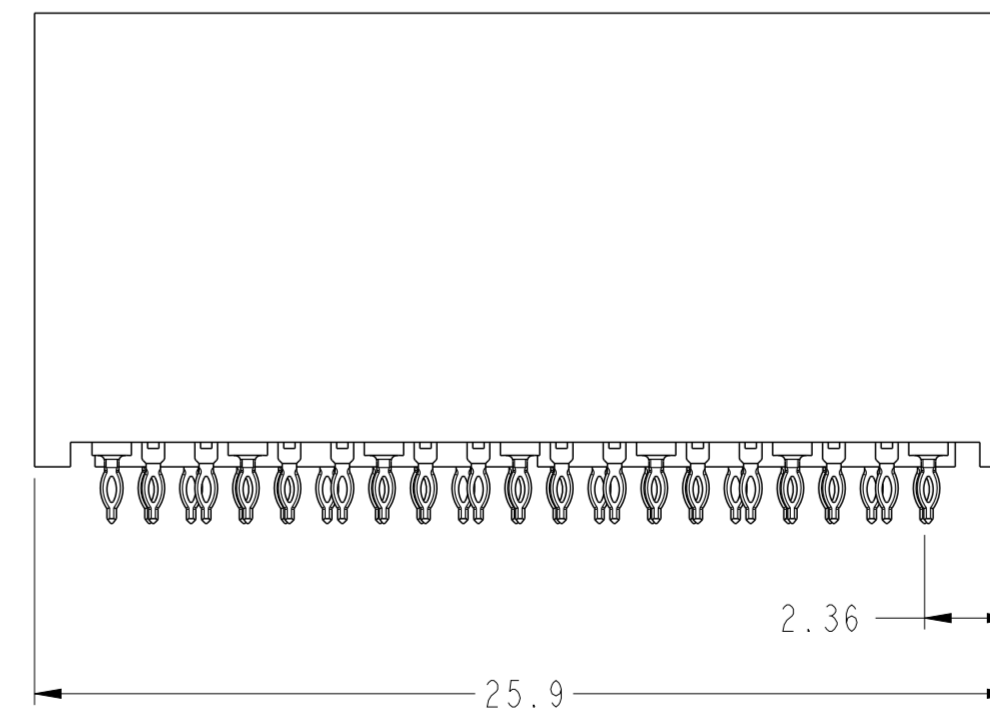
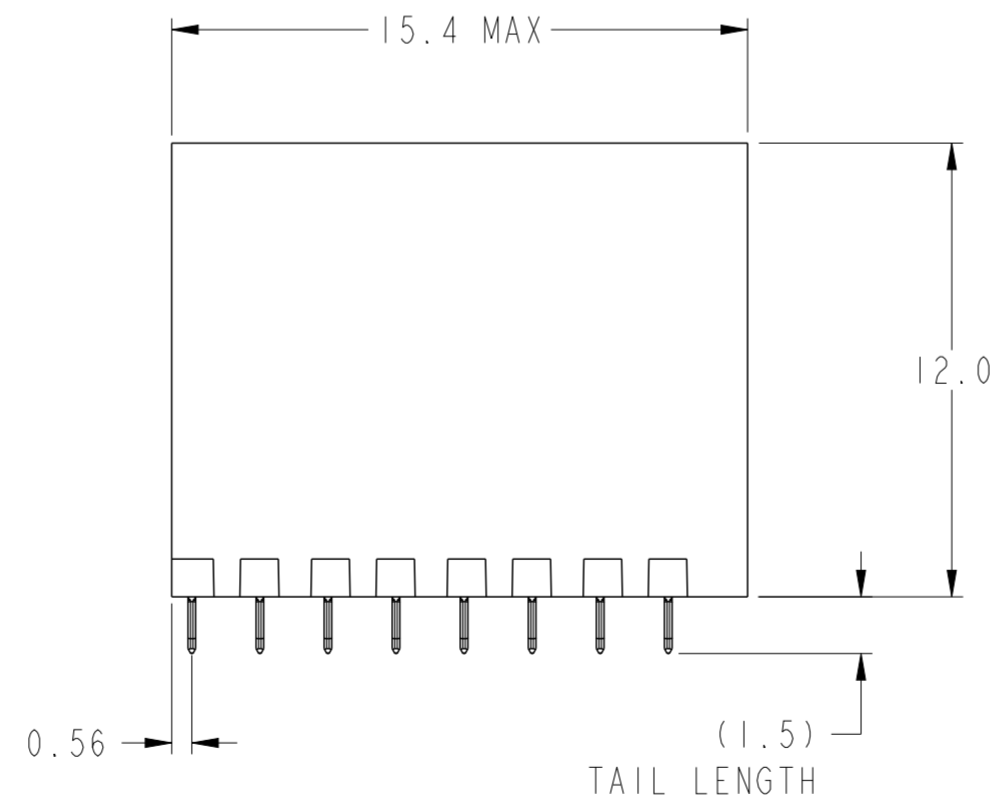
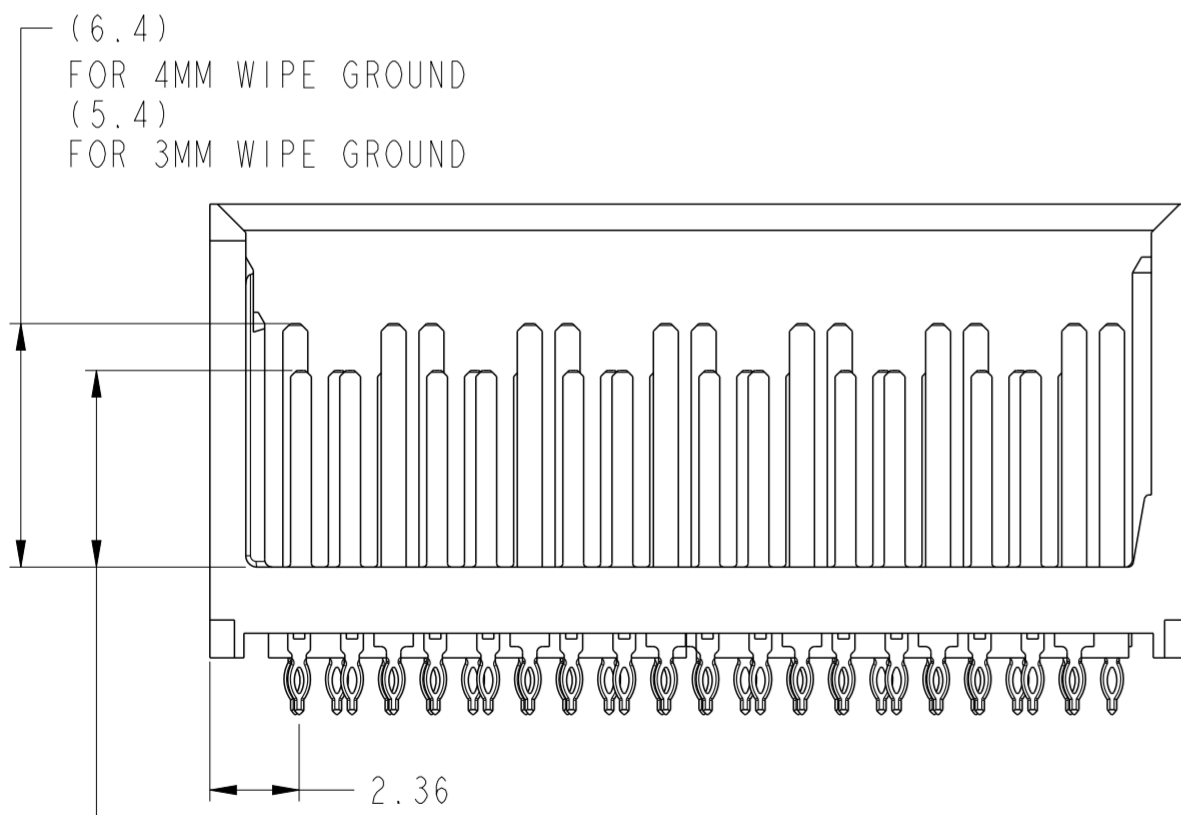

(5.2) FOR 3MM WIPE SIGNAL  
(4.2) FOR 2MM WIPE SIGNAL

spec ref	-	dr	Yong-Keat Lim	2012/02/23	projection	MM	size	A2	scale	5:1										
tolerance std	ASME Y14.5	eng	Sandar Soe	2016/03/08			ecn no	ELX-S-17624-1	rel level	Released										
TOLERANCES UNLESS OTHERWISE SPECIFIED		chr	-	product family			XCEDE HD	rel level		Released										
surface	<table border="1"> <tr> <td>linear</td> <td>0.X</td> <td>±0.3</td> </tr> <tr> <td></td> <td>0.XX</td> <td>±0.10</td> </tr> <tr> <td></td> <td>0.XXX</td> <td>±0.05</td> </tr> <tr> <td>angular</td> <td>0°</td> <td>±2°</td> </tr> </table>	linear	0.X	±0.3		0.XX	±0.10		0.XXX	±0.05	angular	0°	±2°	appr	Chen-Hong Tan	2016/03/17	product family	XCEDE HD	rel level	Released
linear	0.X	±0.3																		
	0.XX	±0.10																		
	0.XXX	±0.05																		
angular	0°	±2°																		
ASME Y14.5	<table border="1"> <tr> <td>linear</td> <td>0.X</td> <td>±0.3</td> </tr> <tr> <td></td> <td>0.XX</td> <td>±0.10</td> </tr> <tr> <td></td> <td>0.XXX</td> <td>±0.05</td> </tr> <tr> <td>angular</td> <td>0°</td> <td>±2°</td> </tr> </table>	linear	0.X	±0.3		0.XX	±0.10		0.XXX	±0.05	angular	0°	±2°	Amphenol FCI	VERTICAL HEADER ASSEMBLY	cat. no.	-	Product - Customer Drw	sheet 4 of 8	
linear	0.X	±0.3																		
	0.XX	±0.10																		
	0.XXX	±0.05																		
angular	0°	±2°																		
		www.fci.com	cat. no.	-	Product - Customer Drw	sheet 4 of 8														

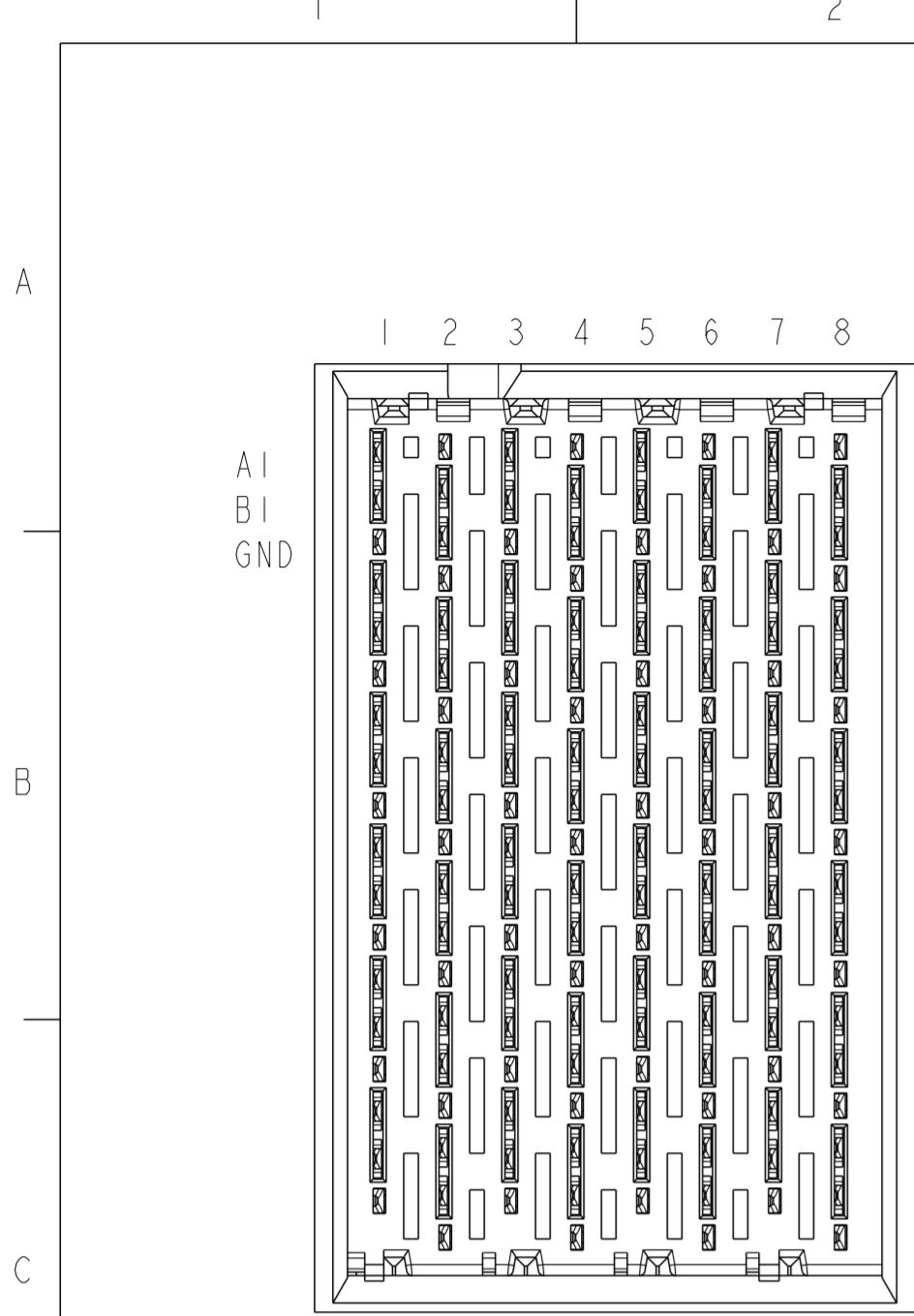

FOUR WALL MODULE

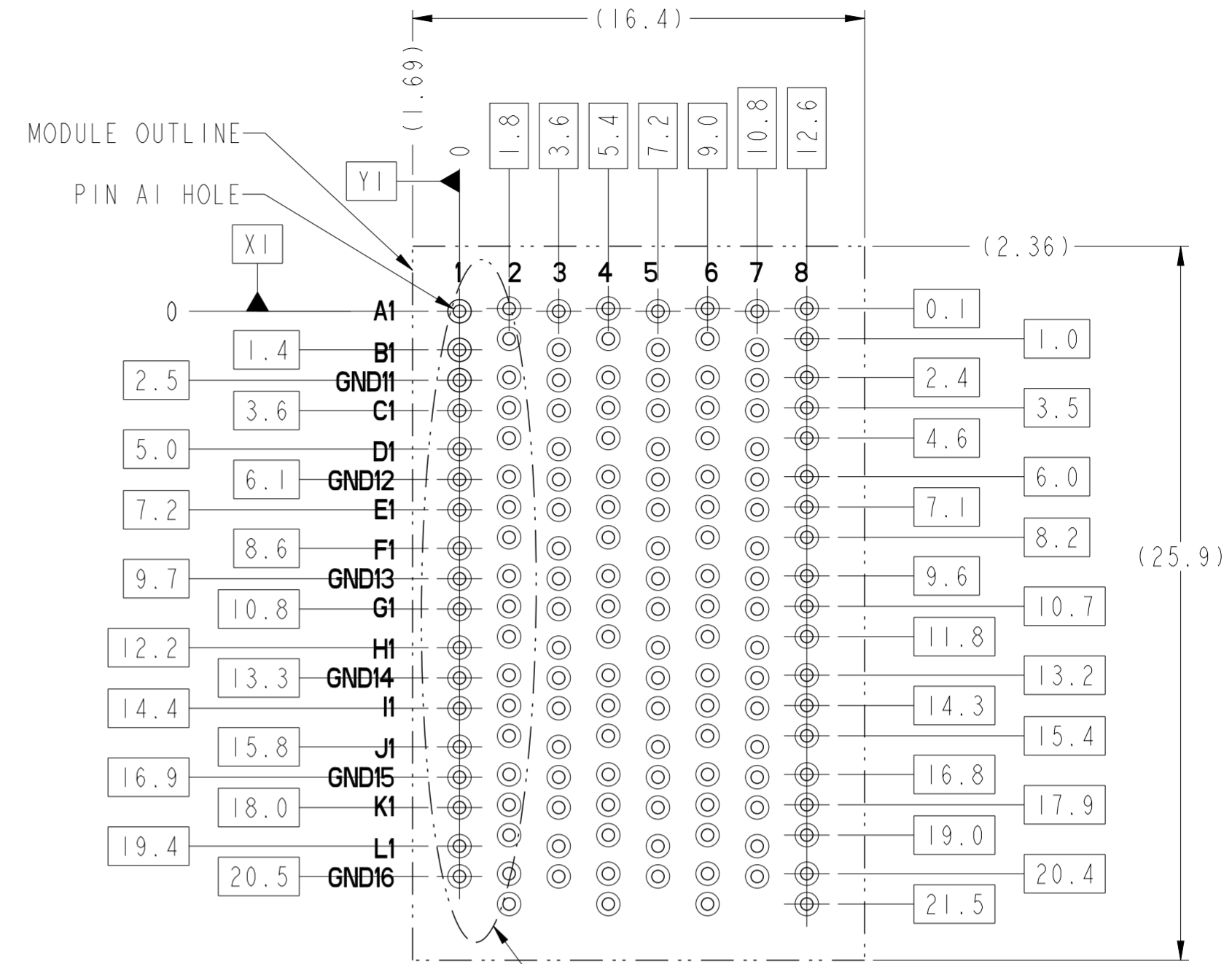
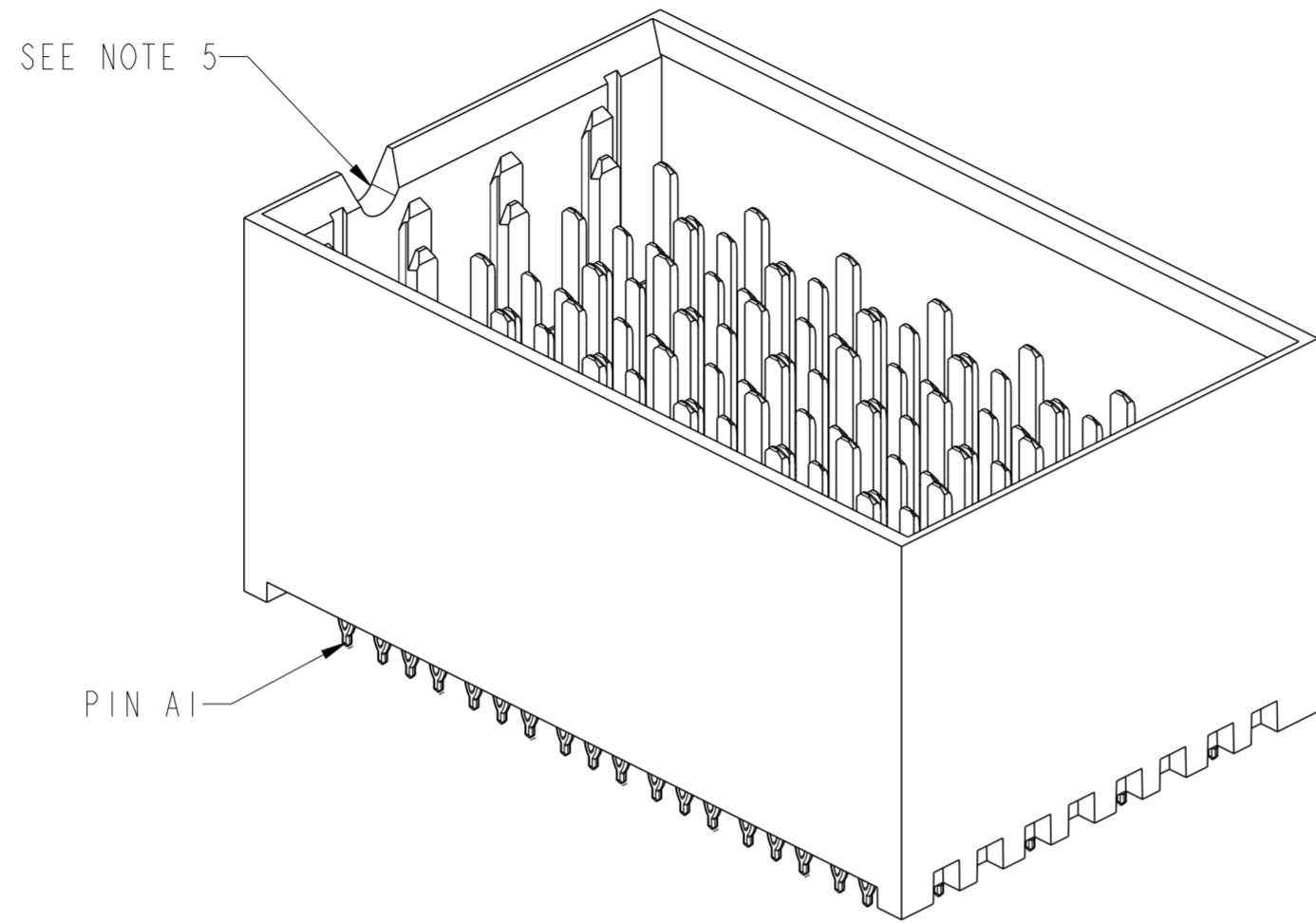

SEE DETAIL A  
ON SHEET 8 FOR PINOUT DETAILS

BP HOLE PATTERN COMPONENT SIDE

FOUR WALL MODULE BACKPLANE FOOTPRINT

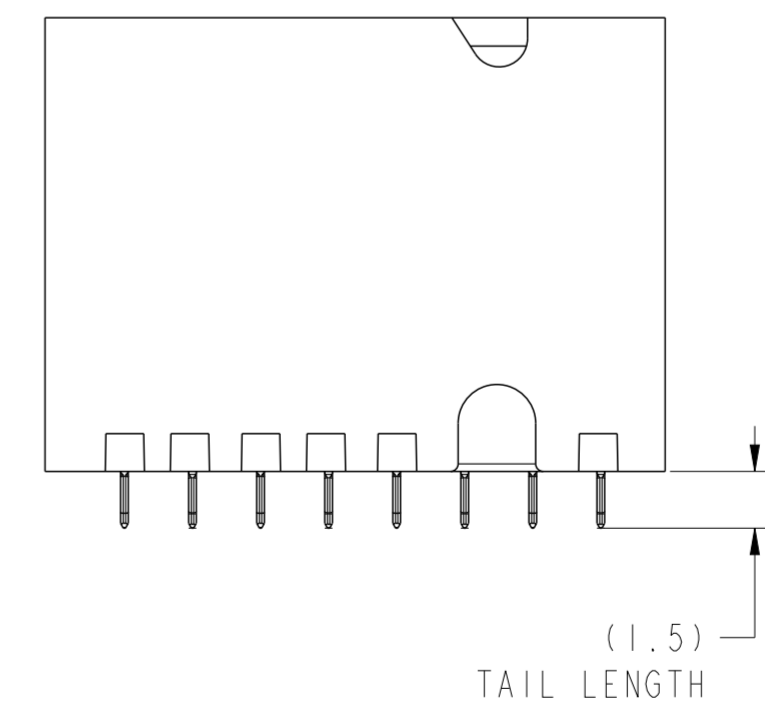
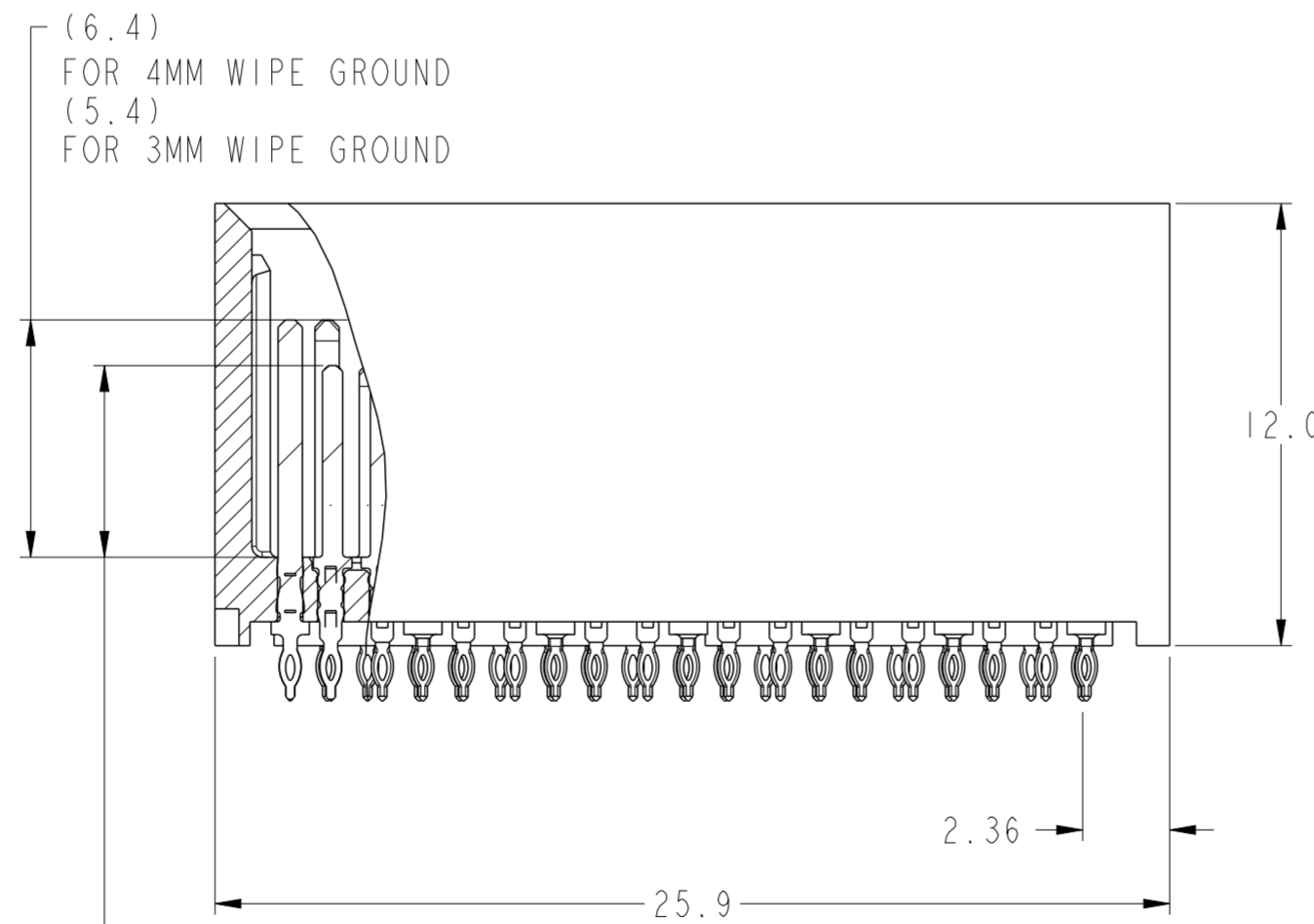
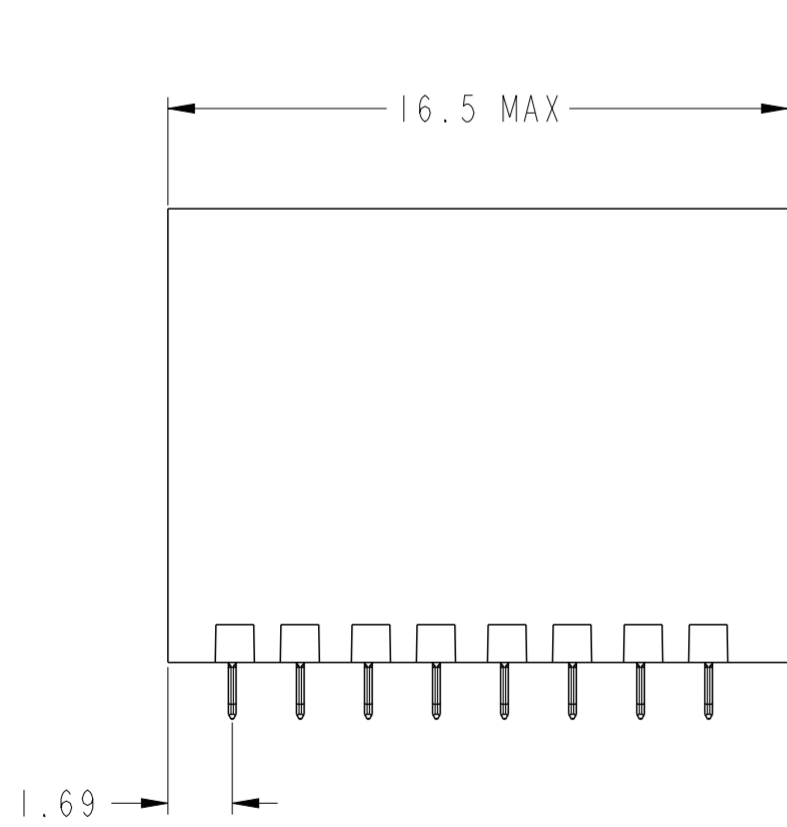

(5.2) FOR 3MM WIPE SIGNAL  
(4.2) FOR 2MM WIPE SIGNAL

spec ref	-	dr	Yong-Keat Lim	2012/02/23	projection	MM	size	A2	scale	5:1
tolerance std	ASME Y14.5	eng	Sandar Soe	2016/03/08			ecn no	ELX-S-17624-1	rel level	Released
TOLERANCES UNLESS OTHERWISE SPECIFIED		chr	-	product family			XCEDE HD	rel level		Released
surface	linear	0.X	±0.3		<b>VERTICAL HEADER ASSEMBLY</b> XCEDE HD 6 PAIR, 8 COLUMN		dwg no	10120132	rev	C
		0.XX	±0.10		www.fci.com	cat. no.	-	Product - Customer Drw	sheet 5 of 8	
	angular	0°	±2°		PDS: Rev :C		STATUS:Released		Printed: Mar 17, 2016	

Amphenol  
FCi

© 2016 AFCI

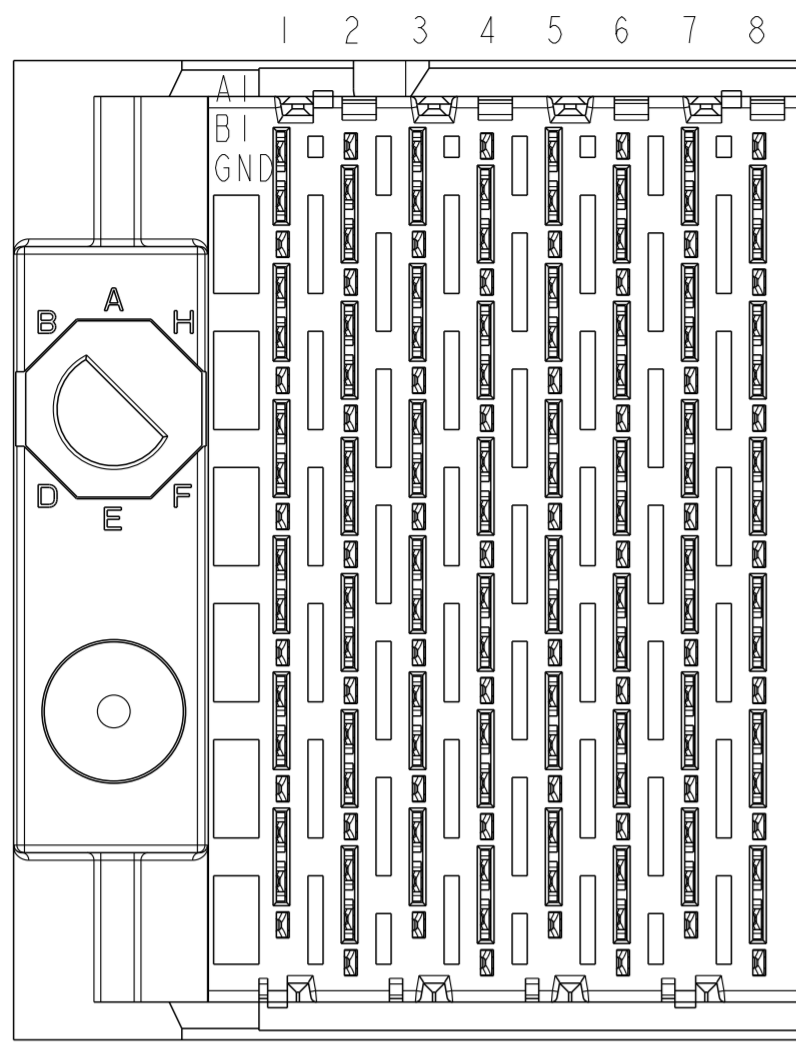

LEFT POLARIZING / GUIDE MODULE

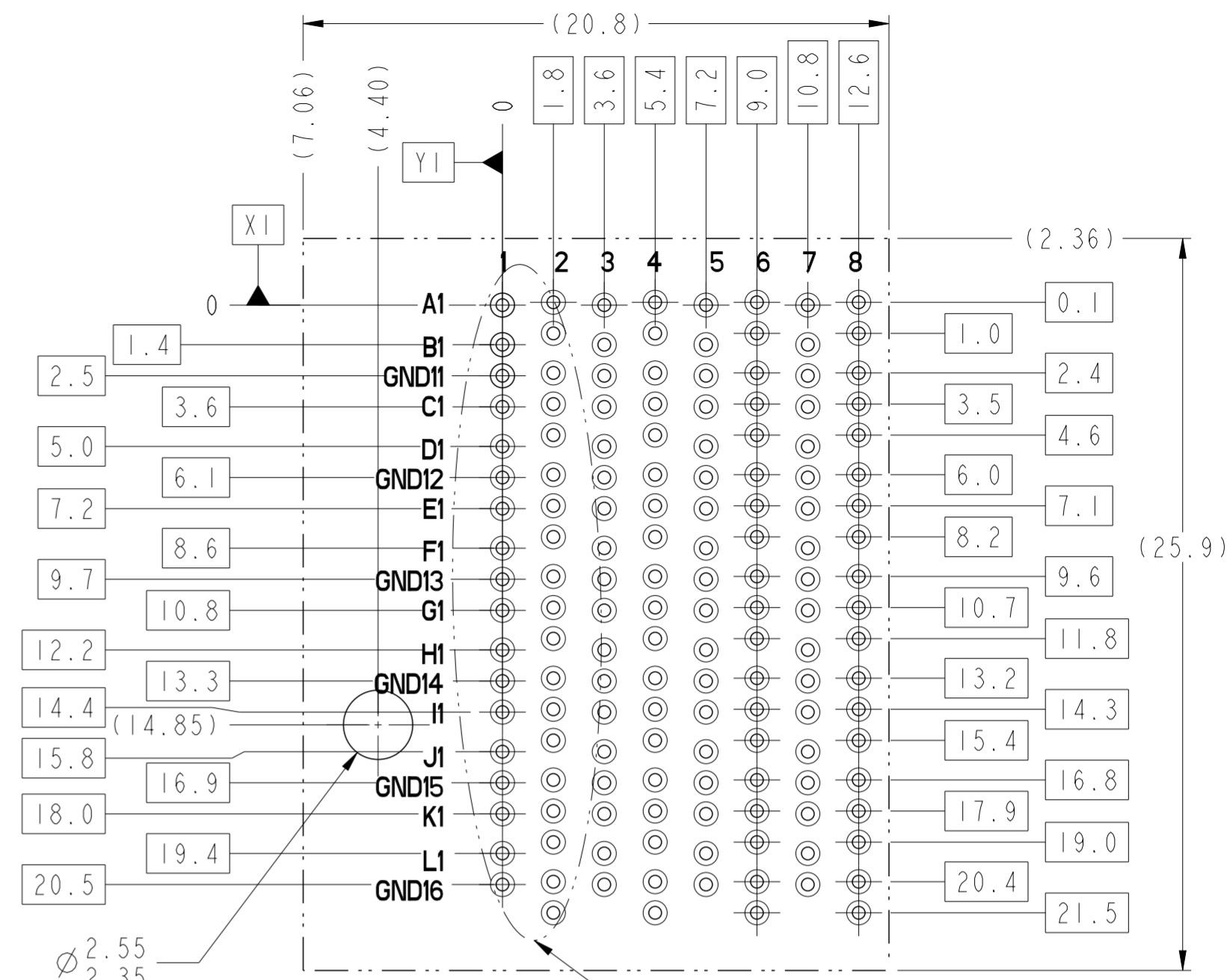
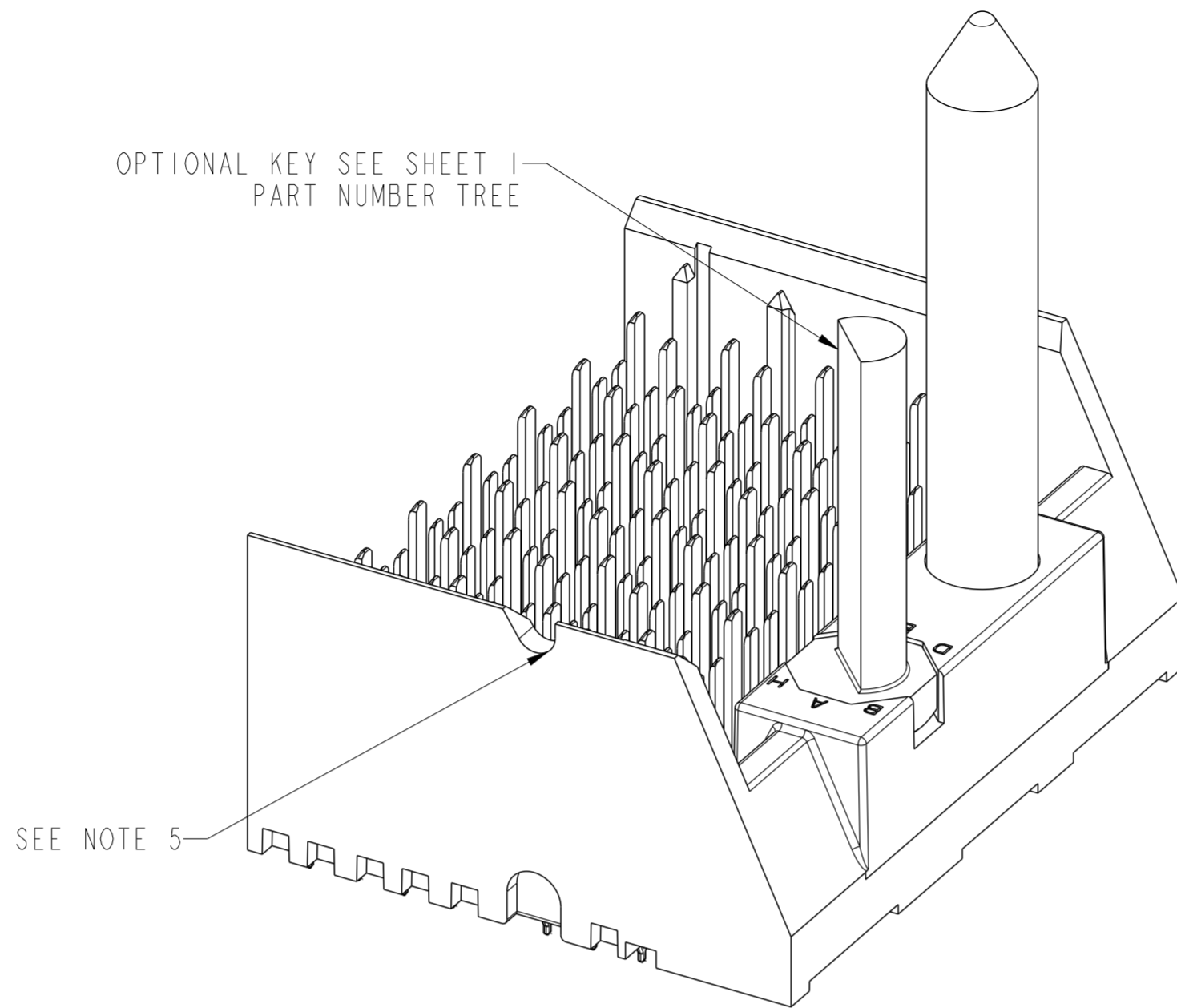

SEE NOTE 11 & TABLE 1

SEE DETAIL A ON SHEET 8 FOR PINOUT DETAILS

BP HOLE PATTERN COMPONENT SIDE  
LEFT POLARIZING GUIDE MODULE  
BACKPLANE FOOTPRINT

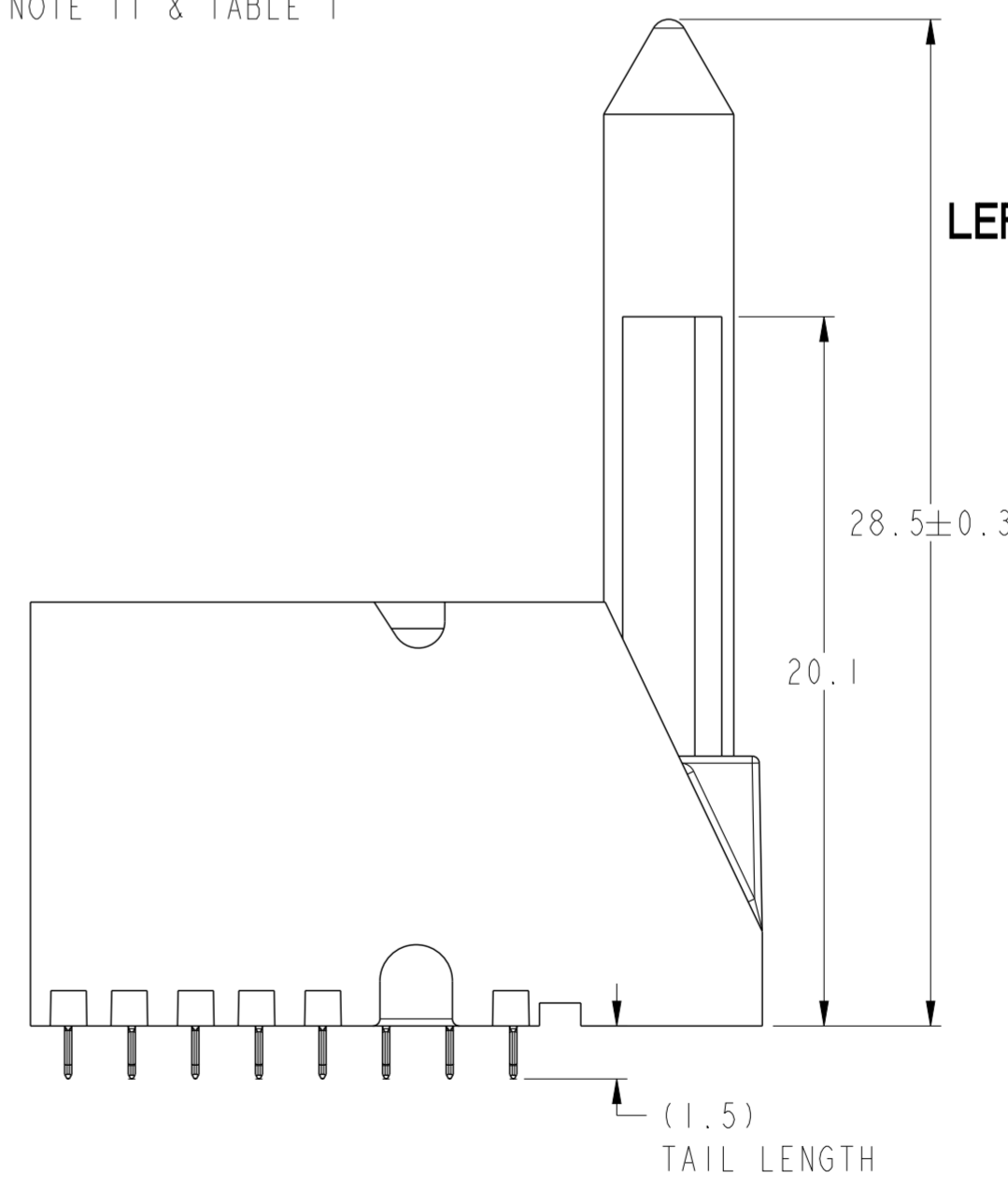
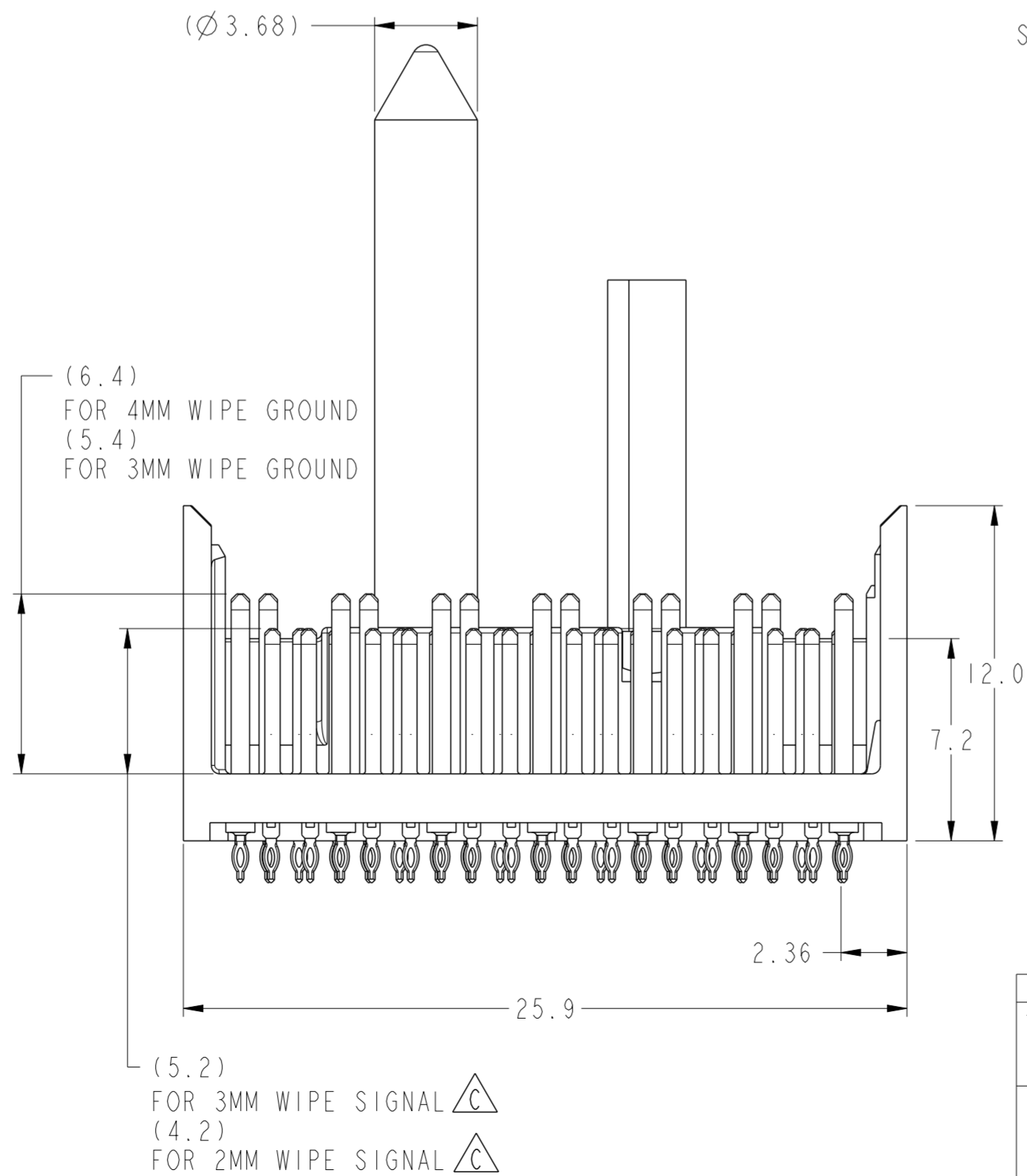
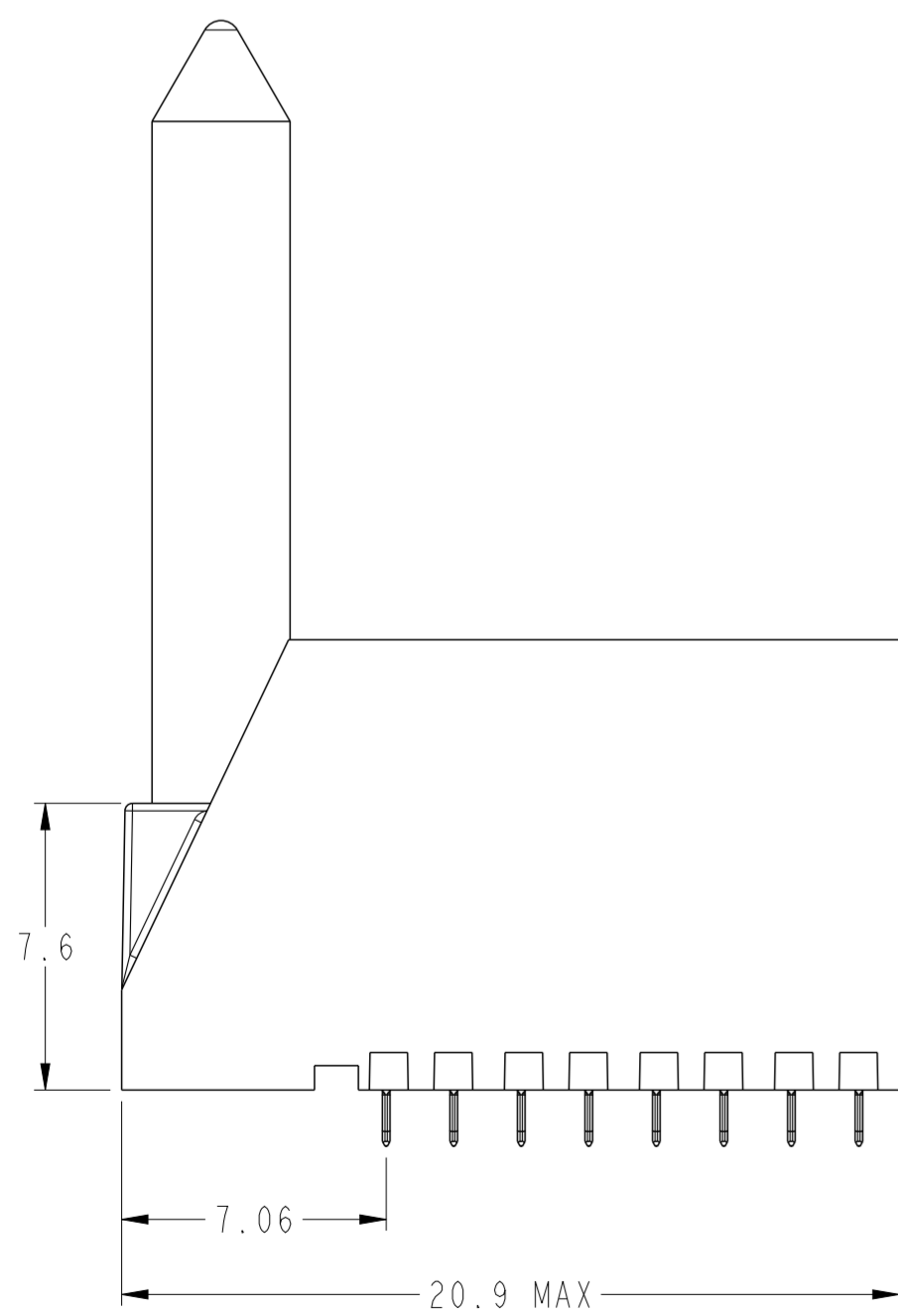

spec ref	-	dr	Yong-Keat Lim	2012/02/23	projection	MM	size	A2	scale	5:1
tolerance std	ASME Y14.5	eng	Sandar Soe	2016/03/08	chr	-	ecn no	ELX-S-17624-1	rel level	Released
surface	linear	appr	Chen-Hong Tan	2016/03/17	product family	XCEDE HD	rel level	Released	cat. no.	10120132
ASME Y14.5	angular	0°	±2°	0.X	±0.3	0.XX	±0.10	0.XXX	±0.05	www.fci.com



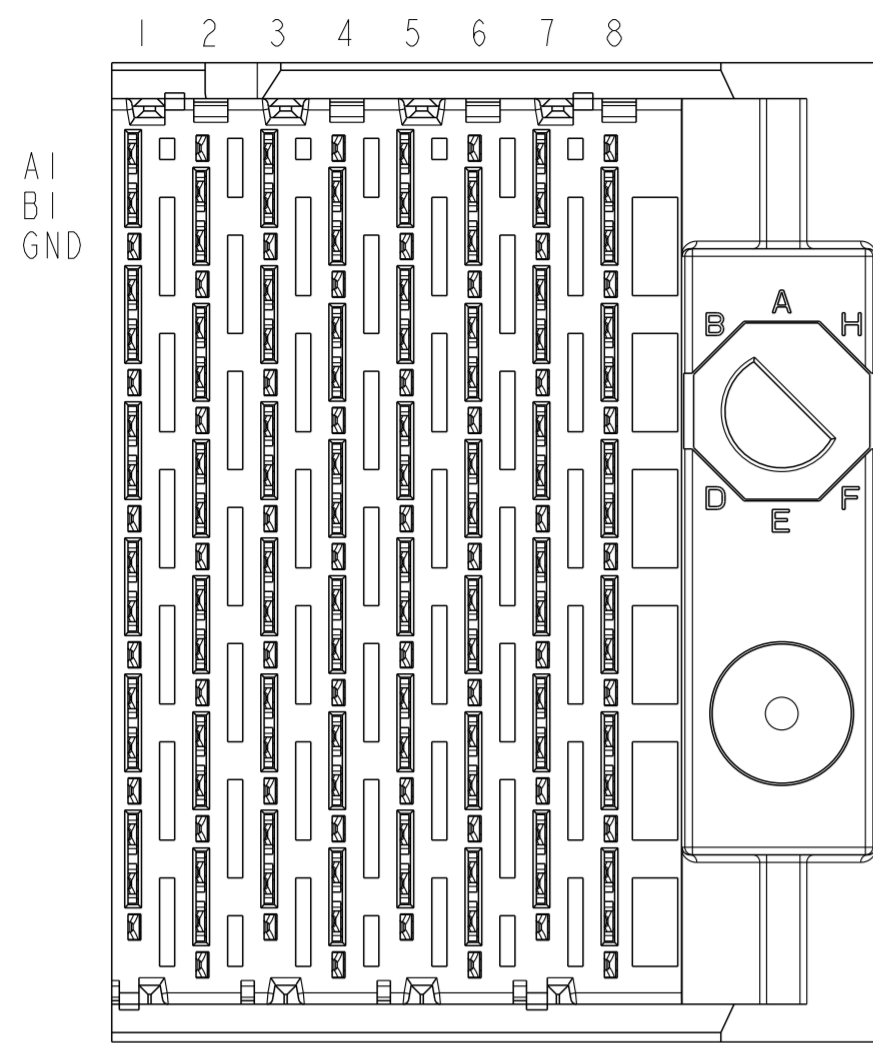

RIGHT POLARIZING GUIDE MODULE

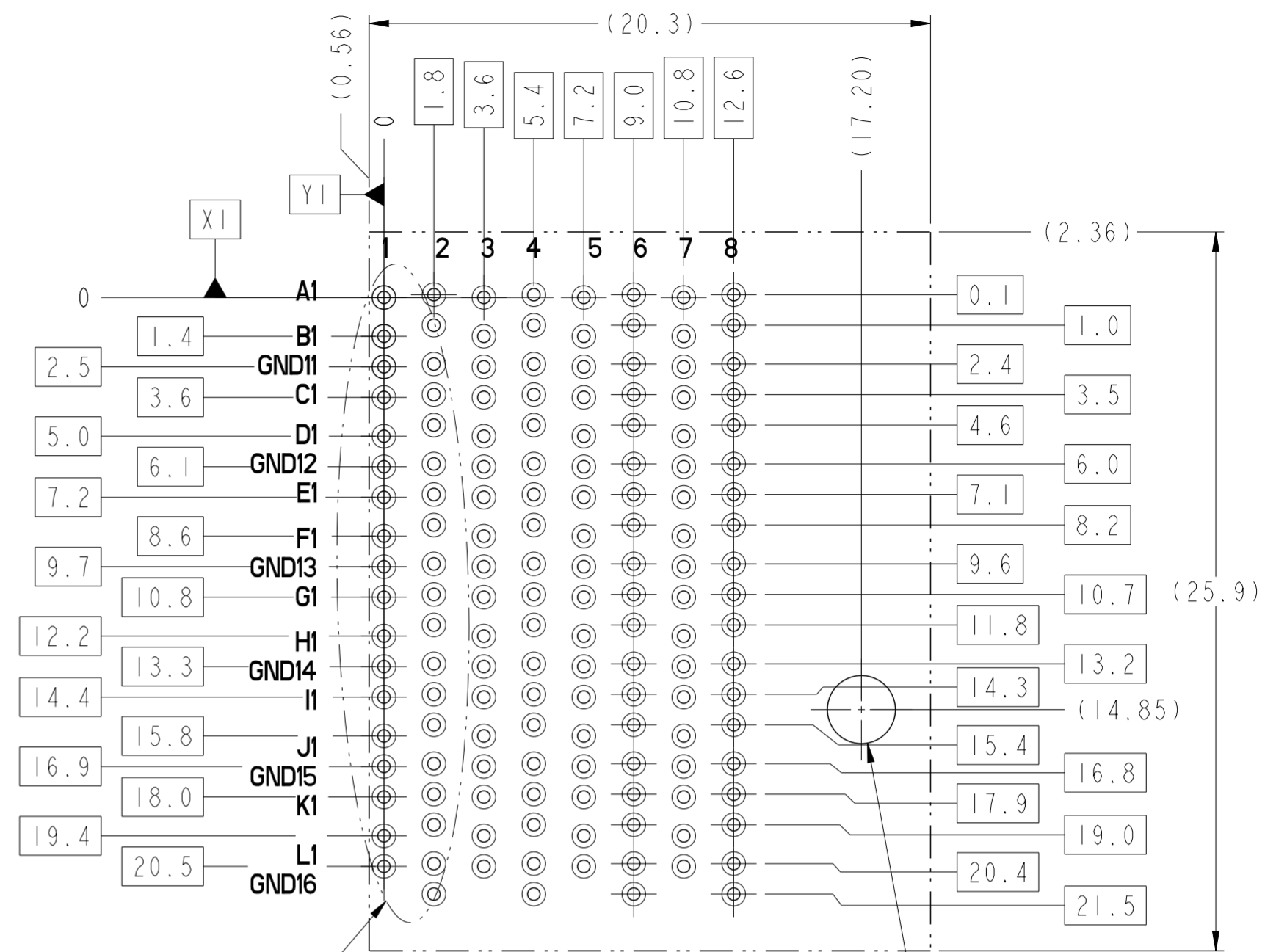
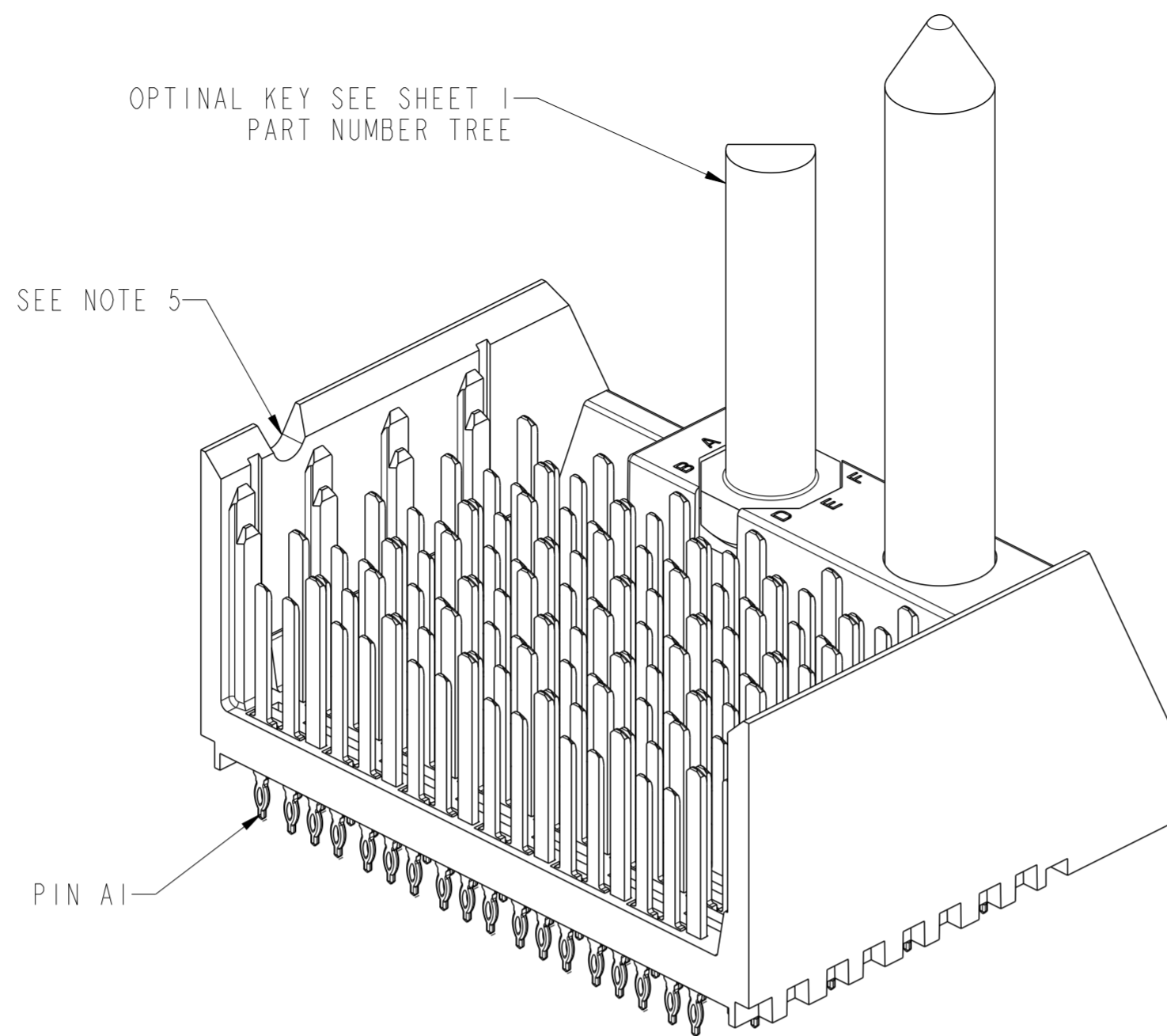

SEE DETAIL A ON SHEET 8 FOR PINOUT DETAILS

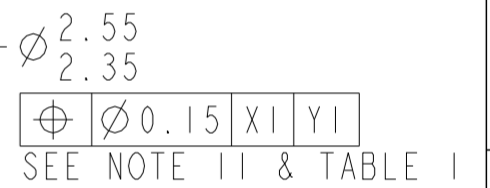

BP HOLE PATTERN COMPONENT SIDE  
RIGHT POLARIZING GUIDE MODULE  
BACKPLANE FOOTPRINT

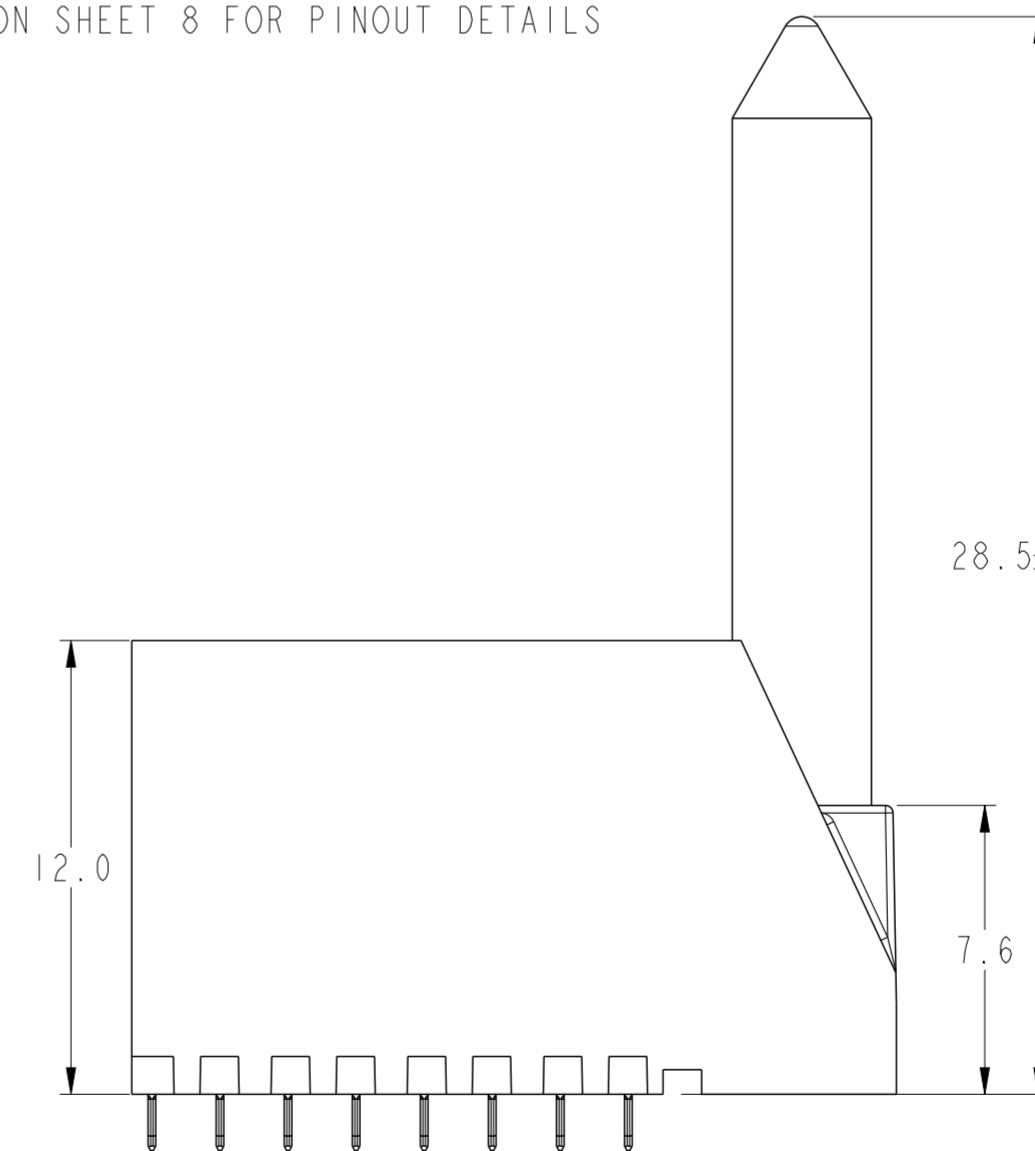
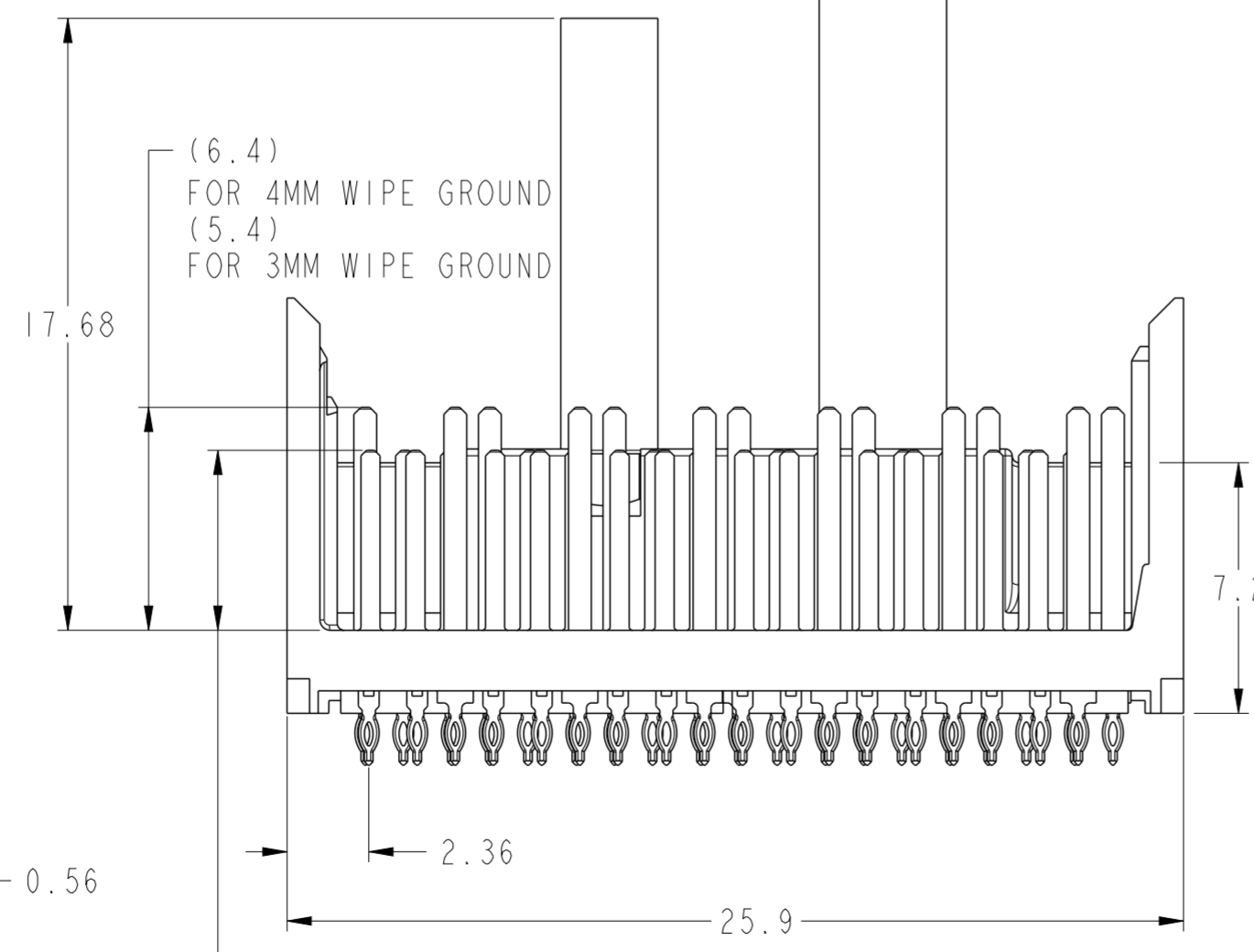
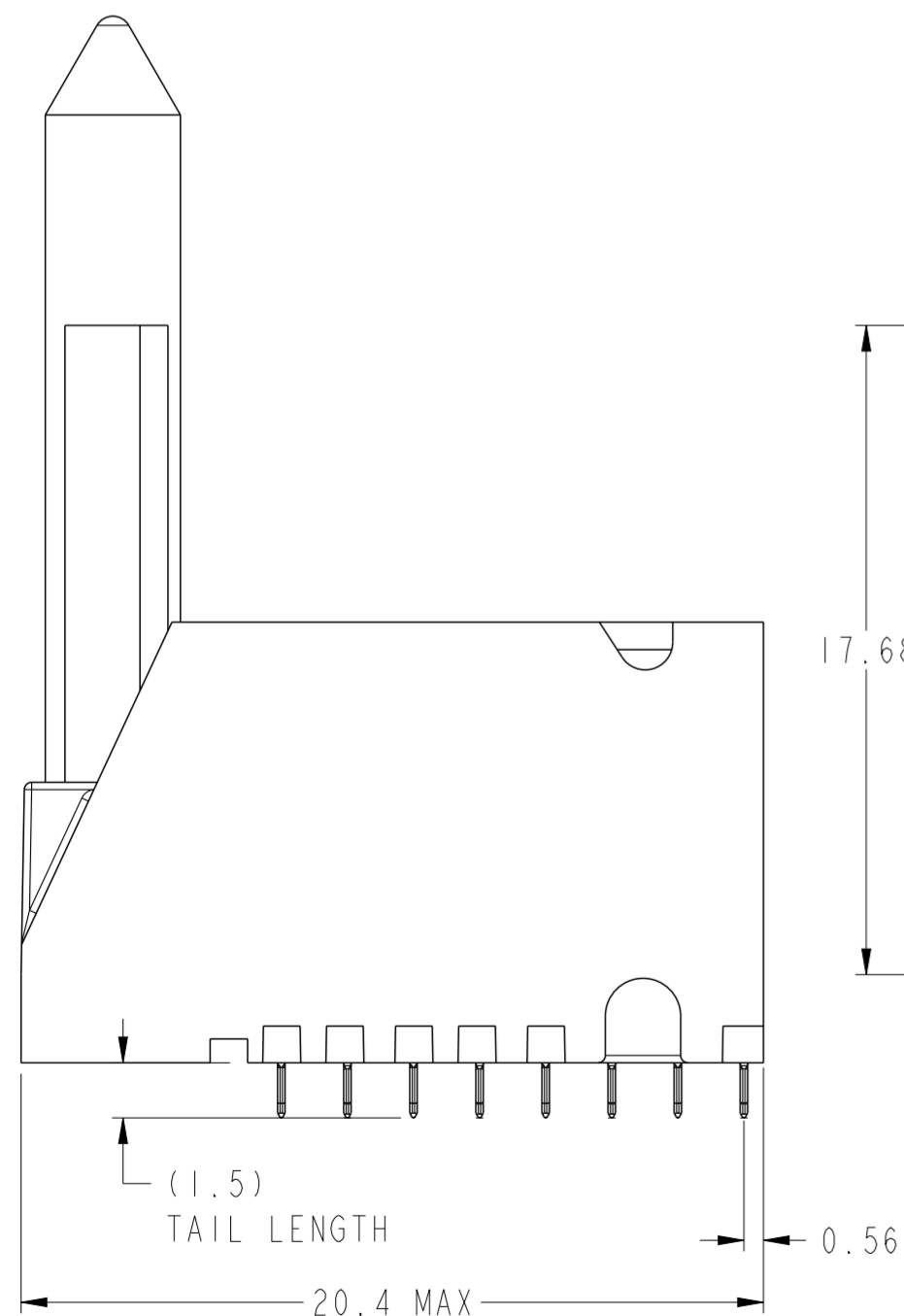

(5.2) FOR 3MM WIPE SIGNAL  
(4.2) FOR 2MM WIPE SIGNAL

spec ref	-	dr	Yong-Keat Lim	2012/02/23	projection	MM	size	A2	scale	5:1
tolerance std	ASME Y14.5	eng	Sandar Soe	2016/03/08	chr	-	ecn no	ELX-S-17624-1	rel level	Released
surface	linear	appr	Chen-Hong Tan	2016/03/17	product family	XCEDE HD	rel level	Released	cat. no.	10120132
ASME Y14.5	angular	0°	±2°	0.X	±0.3	0.XX	±0.10	0.XXX	±0.05	www.fci.com
TOLERANCES UNLESS OTHERWISE SPECIFIED							VERTICAL HEADER ASSEMBLY		XCEDE HD 6 PAIR, 8 COLUMN	
Product - Customer Drw							sheet 7 of 8		rev C	

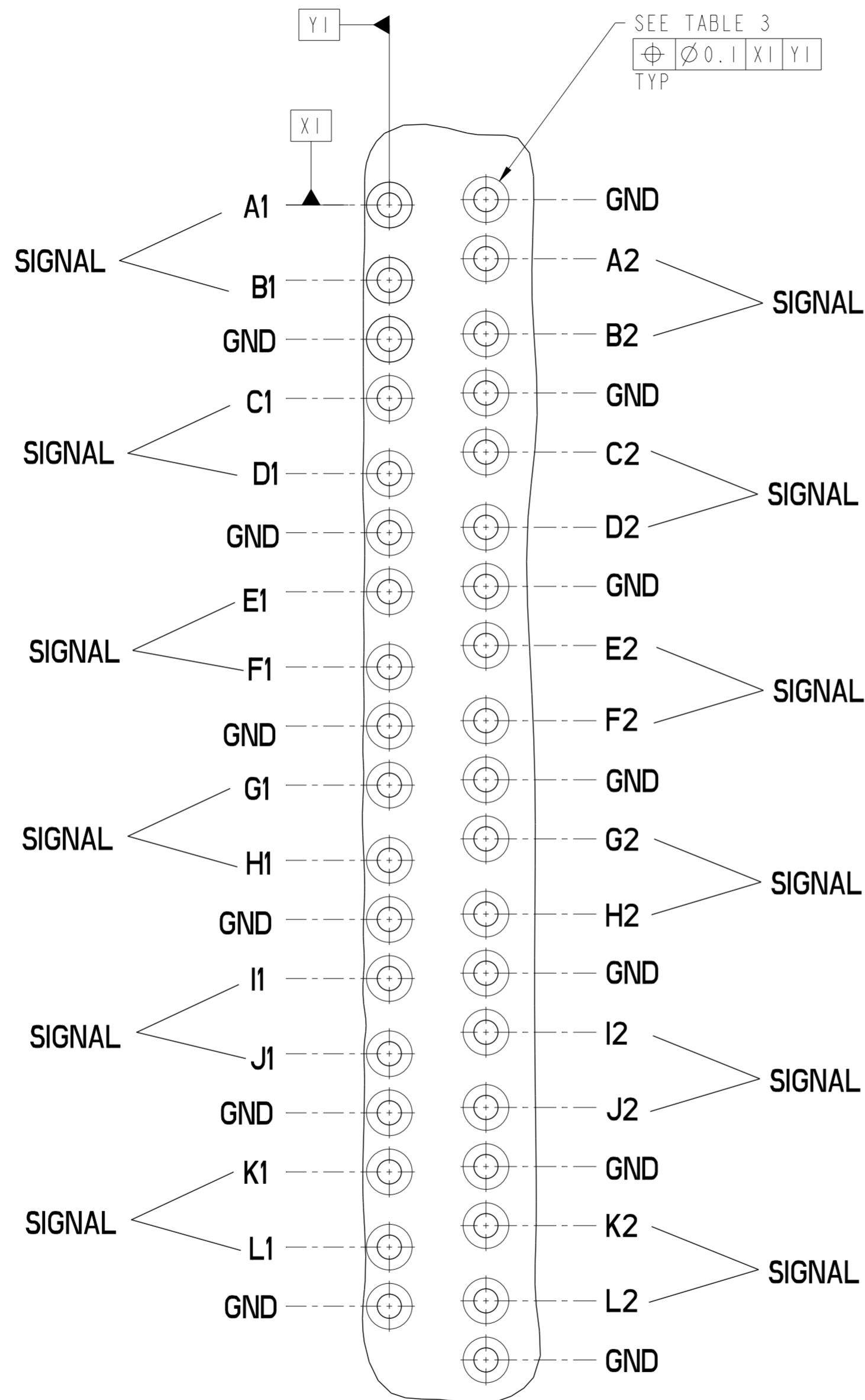

DETAIL A  
SCALE 12:1  
PINOUT DETAILS

TABLE 3		
	COMPLIANT PIN DRILL $\varnothing 0.55[0.0217"]$	COMPLIANT PIN DRILL $\varnothing 0.45[0.0117"]$
PTH	$\varnothing 0.45 \pm 0.05$	$\varnothing 0.36 \pm 0.05$
DRILL	$\varnothing 0.55[0.0217"]$	$\varnothing 0.45[0.0117"]$
PAD	$\varnothing 0.85$	$\varnothing 0.75$

NOTES:

1. CONNECTOR MATERIALS  
SHROUD : HIGH-TEMP POLYMER, COLOR : BLACK, UL94V-0  
CONTACTS : HIGH PERFORMANCE COPPER ALLOY
2. PRODUCT SPECIFICATION : GS-12-0936
3. APPLICATION SPECIFICATION : GS-20-0348
4. PRODUCT MARKING :  
PART NUMBER (10120132-X0E-XXXLF)  
"FCI" AND DATE CODE (FCI P#####)
- ⑤ NOTCH DESIGNATES "ROW A" SIDE OF CONNECTOR. NOTCH FEATURE ON OPPOSITE FOR PRODUCT MARKING.
- ⑥ PLATING THICKNESS OF SIGNAL & GROUND CONTACT ARE DETERMINED BY PLATING CODE, REFER TO P/N TREE ON SHEET 1.
7. PACKAGING MEETS GS-14-920 LEAD-FREE LABELING SPECIFICATION.
- ⑧ GUIDE-PIN STYLE DESIGNATION ONLY APPLIES TO MODULE VERSIONS THAT REQUIRE GUIDE-PIN HARDWARE. FOR ALL NON-GUIDE-PIN VERSIONS, THE DEFAULT DASH-NUMBER DIGIT IN THAT LOCATION IS STILL "0".
- ⑨ SEE APPLICATION SPECIFICATION FOR ROUTING GUIDELINES, ADDITIONAL PTH GUIDELINES, MATED DIMENSIONS, GUIDE PIN SELECTION, ETC.
10. A  $\triangle$  SYMBOL WILL BE NEXT TO ANY DIMENSION, VIEW OR NOTE THAT HAS BEEN MODIFIED WITH THE CURRENT DRAWING REVISION.
- ⑪ OPTIONAL HOLE LOCATION FOR GROUNDED PIN OR ADDITIONAL GUIDE-PIN SUPPORT. SEE TABLE 1 SHEET 1 FOR ADDITIONAL DETAILS.
- ⑫ SCREW IS OPTIONAL AND ENGAGES WITH BOTTOM OF GUIDE PIN FROM BENEATH THE PCB FOR ADDITIONAL GUIDE-PIN SUPPORT.

spec ref	-	dr	Yong-Keat Lim	2012/02/23	projection	MM	size	A2	scale	3:1	
tolerance std	ASME Y14.5	eng	Sandar Soe	2016/03/08			ecn no	ELX-S-17624-1	rel level	Released	
TOLERANCES UNLESS OTHERWISE SPECIFIED		chr	-	appr			Chen-Hong Tan	2016/03/17		product family	XCEDE HD
surface	ASME Y14.5	linear	0.X	$\pm 0.3$	Amphenol FCI		VERTICAL HEADER ASSEMBLY	cat. no.	10120132	rev	C
		angular	0°	$\pm 2^\circ$	www.fci.com		XCEDE HD 6 PAIR, 8 COLUMN	Product - Customer Drw	sheet 8 of 8		