

DO NOT SCALE FROM THIS PRINT

PRF24-J-C-EP-140B-SS

SERIES
-24: 2.4MM

GENDER
-J: JACK

TYPE
-C: CABLE

TERMINATION
-S: SOLDER CLAMP

ORIENTATION
-S: STRAIGHT

CABLE TYPE
-140: INSULATED WIRE 1401

PLATING
-EP: 50µ" EXTRA HEAVY GOLD
CENTER CONTACT, PASSIVATED
OUTER CONTACT

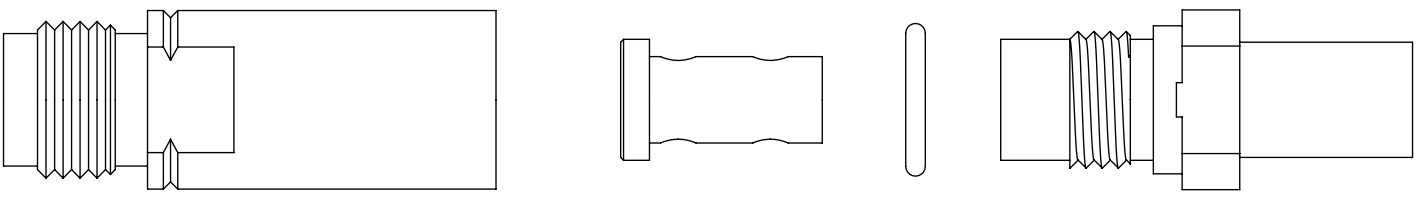
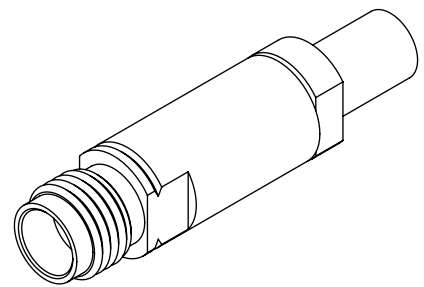
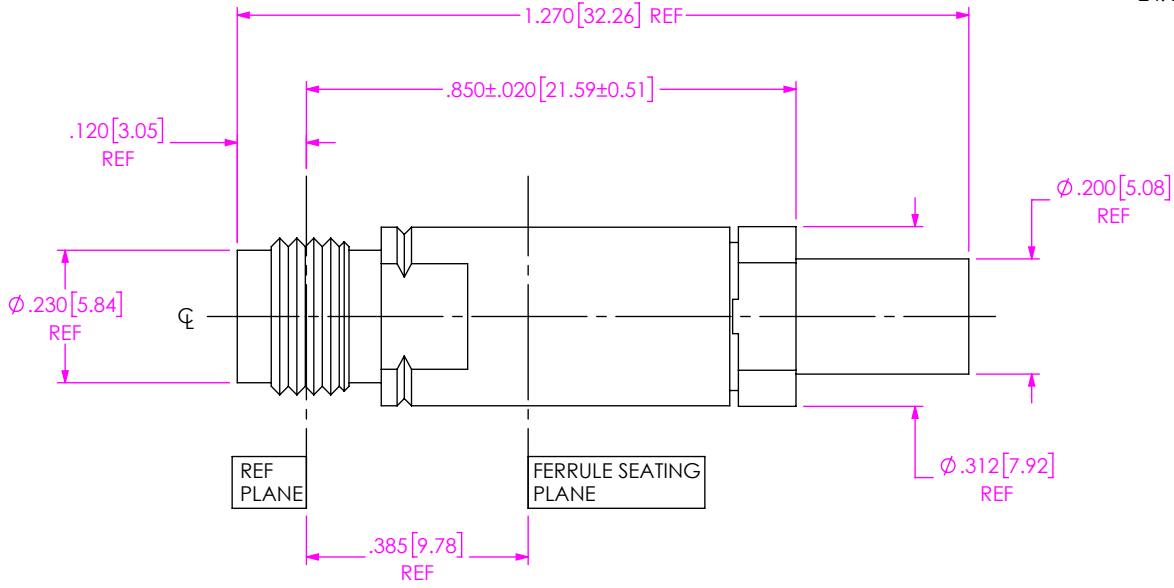

EXPLODED VIEW
NOT TO SCALE
(FOR CLARITY ONLY)

- NOTES:
- MATERIAL:
BODY, CLAMP NUT, OUTER CONTACT: STAINLESS STEEL.
O-RING: SILICONE RUBBER.
BEAD: ULTEM.
SOLDER FERRULE: BRASS ALLOY
CONTACT: BERYLLIUM COPPER.
 - FINISH:
BODY, CLAMP NUT, OUTER CONTACT: PASSIVATED.
CONTACT, SOLDER FERRULE: GOLD OVER NICKEL PLATE,
50 µIN MIN GOLD OVER 50 µIN MIN NICKEL.
 - PCI P/N: 3176.

UNLESS OTHERWISE SPECIFIED, DIMENSIONS ARE IN INCHES. TOLERANCES ARE: DECIMALS ANGLES .XX: ±.01 1° .XXX: ±.005 .XXXX: ±.0005	* PROPRIETARY NOTE * THIS DOCUMENT CONTAINS CONFIDENTIAL AND PROPRIETARY INFORMATION AND ALL DESIGN, MANUFACTURING, REPRODUCTION, USE, PATENT RIGHTS AND SALES RIGHTS ARE EXPRESSLY RESERVED BY SAMTEC, INC. THIS DOCUMENT SHALL NOT BE DISCLOSED, IN WHOLE OR PART, TO ANY UNAUTHORIZED PERSON OR ENTITY NOR REPRODUCED, TRANSFERRED OR INCORPORATED IN ANY OTHER PROJECT IN ANY MANNER WITHOUT THE EXPRESS WRITTEN CONSENT OF SAMTEC, INC.	 520 PARK EAST BLVD, NEW ALBANY, IN 47150 PHONE: 812-944-6733 FAX: 812-948-5047 e-Mail: info@SAMTEC.com code 55322
		DESCRIPTION: 2.4MM JACK ASSEMBLY FOR INSULATED WIRE 1401
		DWG. NO. PRF24-J-C-EP-140B-SS
DO NOT SCALE DRAWING SHEET SCALE: 3:1		BY: CANDY W 05/16/2019 SHEET 1 OF 2

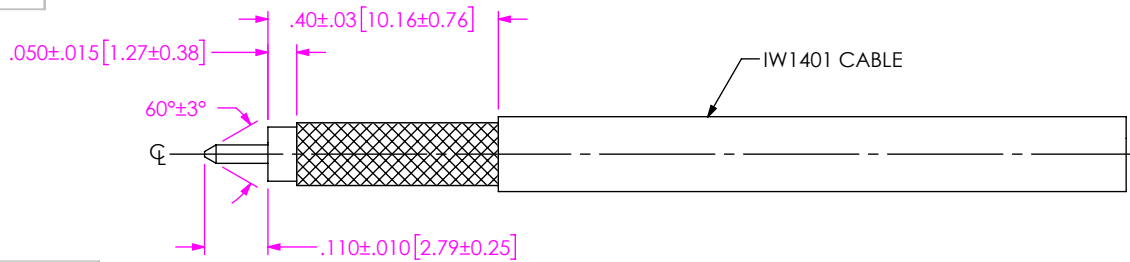

1. TRIM CABLE AND POINT CENTER CONDUCTOR AS SHOWN.

IN-PROCESS VIEW 1

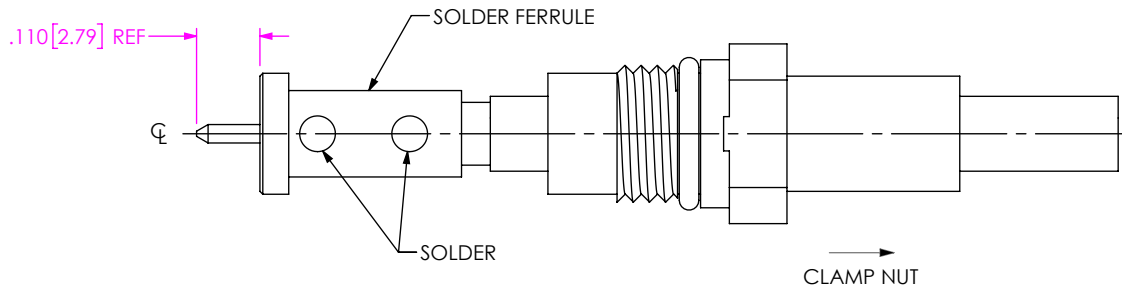

2A. SLIDE CLAMP NUT OVER CABLE AS SHOWN.

2B. INSERT CABLE INTO SOLDER FERRULE UNTIL SEATED AND SOLDER TO CABLE BRAID & FOIL.

IN-PROCESS VIEW 2

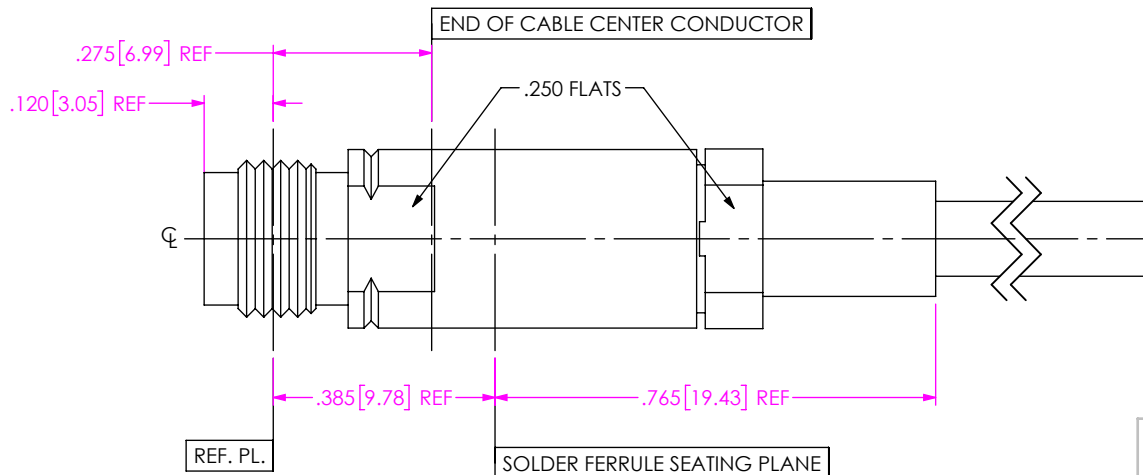

3A. INSERT CABLE/FERRULE SUB-ASSEMBLY INTO CONNECTOR UNTIL SEATED AND TIGHTEN CLAMP NUT TO 25-35 IN-LBS.

3B. GAGE INTERFACE USING APPROPRIATE GAGE (CONTACT RANGE 000/.003 SUB-FLUSH).

DISTANCE FROM END OF CABLE CENTER COND. TO REF. PL. IS .275 (REF.)

IN-PROCESS VIEW 3

PROPRIETARY NOTE
 THIS DOCUMENT CONTAINS CONFIDENTIAL AND PROPRIETARY INFORMATION AND ALL DESIGN, MANUFACTURING, REPRODUCTION, USE, PATENT RIGHTS AND SALES RIGHTS ARE EXPRESSLY RESERVED BY SAMTEC, INC. THIS DOCUMENT SHALL NOT BE DISCLOSED, IN WHOLE OR PART, TO ANY UNAUTHORIZED PERSON OR ENTITY NOR REPRODUCED, TRANSFERRED OR INCORPORATED IN ANY OTHER PROJECT IN ANY MANNER WITHOUT THE EXPRESS WRITTEN CONSENT OF SAMTEC, INC.



520 PARK EAST BLVD, NEW ALBANY, IN 47150
 PHONE: 812-944-6733 FAX: 812-948-5047
 e-Mail: info@SAMTEC.com code 55322

DO NOT SCALE DRAWING

SHEET SCALE: 3:1

DESCRIPTION: 2.4MM JACK ASSEMBLY FOR INSULATED WIRE 1401

DWG. NO. PRF24-J-C-EP-140B-SS

BY: CANDY W 05/16/2019 SHEET 2 OF 2