

THIS DRAWING IS UNPUBLISHED. RELEASED FOR PUBLICATION, 19 .
 © COPYRIGHT 19 BY AMP INCORPORATED. ALL INTERNATIONAL RIGHTS RESERVED.

LOC	DIST	P	F	REVISIONS				
G	14			ZONE	LTR	DESCRIPTION	DATE	APPD
					G	REV 0L20-0025-97	30JAN97	ME TM

AMP WIRE RANGE	UL Listed	SR LR7189 Certified
22-16 AWG SOLID OR STRANDED	22-16 AWG SOLID OR STRANDED	22-16 AWG SOLID OR STRANDED

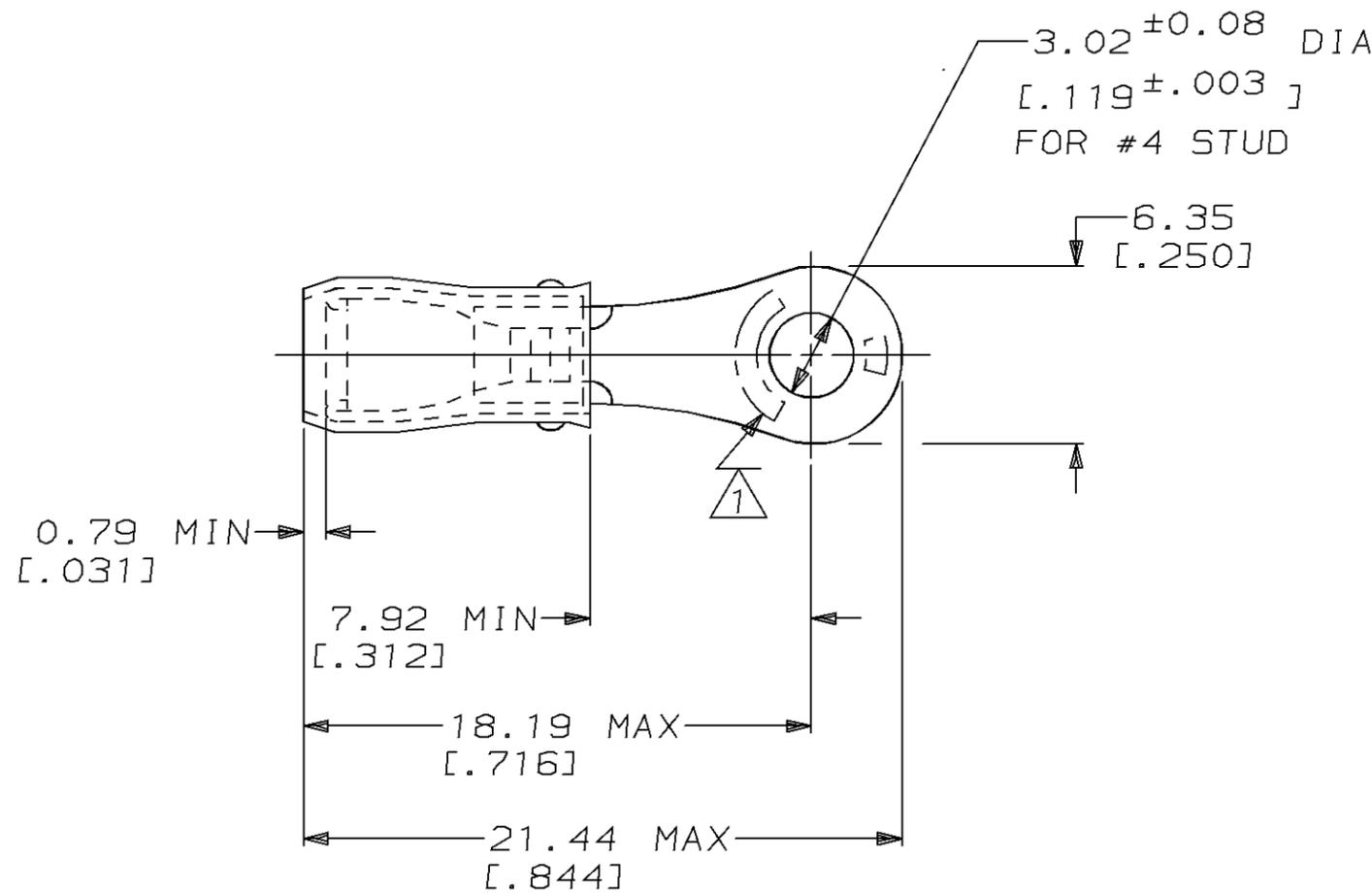

- 1 STAMP AMP 22-18* 1-2 APPROX AS SHOWN
22-16 TERMINALS ARE STAMPED 22-18 IN
ACCORDANCE WITH MILITARY SPEC MIL-T-7928
COMMERCIAL WIRE RANGE IS 22-16
- 2 WIRE INSULATION DIA: .080 - .125
- 3 TONGUE MATERIAL THK: 0.79^{±0.05} [.031^{±.002}]

AMP INCORPORATED CUSTOMER SERVICE SYSTEMS		MAX RECOMMENDED OPERATING TEMPERATURE: 105°C MAX	MILITARY P/N AND CLASS	5000	ON TAPE, REEL	2-323758-1
FOR ADDITIONAL PRODUCT INFORMATION OR COPIES OF DRAWINGS AND TECHNICAL DOCUMENTS	PRODUCT INFORMATION CENTER 1-800-522-6752	VOLTAGE RATING: 300 V MAX	DO NOT SCALE PRINT, UNLESS SPECIFIED DIMENSIONS IN mm [INCHES] TOLERANCES ON: 2 PLC DEC ± 0.20 [.008] 3 PLC DEC ± - ANGLES ± -	-	LOOSE PIECE	323758
FOR APPLICATION TOOLING INFORMATION	TOOLING ASSISTANCE CENTER 1-800-722-1111	WIRE CROSS SECTIONAL AREA RANGE: 0.26-1.65mm ² [509-3,260] CIR MILS SOLID OR STRANDED	MATERIAL COPPER PER ASTM B-152 SLEEVE, RED NYLON	QUANTITY	PACKAGE TYPE	PART NO
FOR ORDER ENTRY	1-800-526-5142	THIS DRAWING IS A CONTROLLED DOCUMENT FOR AMP INCORPORATED. IT IS SUBJECT TO CHANGE AND THE CONTROLLING ENGINEERING ORGANIZATION SHOULD BE CONTACTED FOR THE LATEST REVISION.	FINISH TIN PLATE PER MIL-T-10727	DR 02/11/93 DK SCHRUM CHK 4/28/93 RE HERSEY APPD 4/28/93 ML ELLIS APPD 4/28/93 M BARNABA PRODUCT SPEC UL 486A APPLICATION SPEC NOT AVAILABLE WEIGHT -	AMP AMP Incorporated Harrisburg, PA 17105-3608 NAME TERMINAL, RING TONGUE, PIDG™, WIRE SIZE, 22-16 AWG SIZE B CAGE CODE 00779 DRAWING NO C-323758 SCALE 4:1 SHEET 1 OF 1	