

MATERIALS AND FINISHES

BODY, WASHER, RETAINING RING BRASS  
PLATED NICKEL

CENTER CONTACT BRASS  
PLATED GOLD

INSULATOR TEFLON

COUPLING NUT ZINC ALLOY  
PLATED NICKEL

SPRING WASHER PHOSPHOR BRONZE  
PLATED NICKEL

GASKET SILICONE RUBBER

CABLE ATTACHMENT:

INNER CONTACT: SOLDER OR CRIMP USING 4.29 (1.69) HEX  
CRIMP TUBE: CRIMP USING 5.41 (.213) HEX

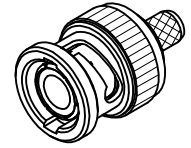

INTERFACE PER  
MOLEX STANDARD  
ES-73599-0000

RG58/RG141 CABLE

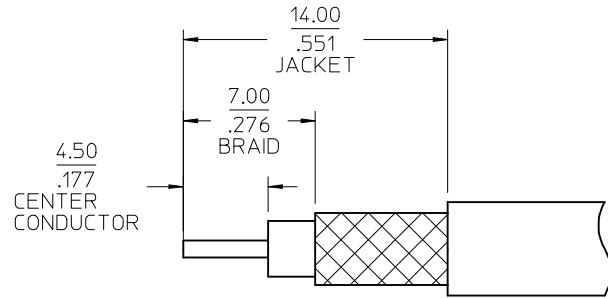
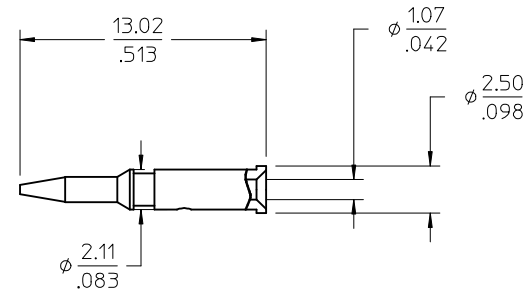
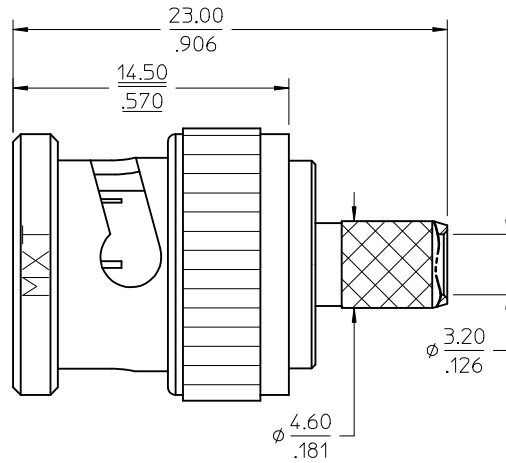
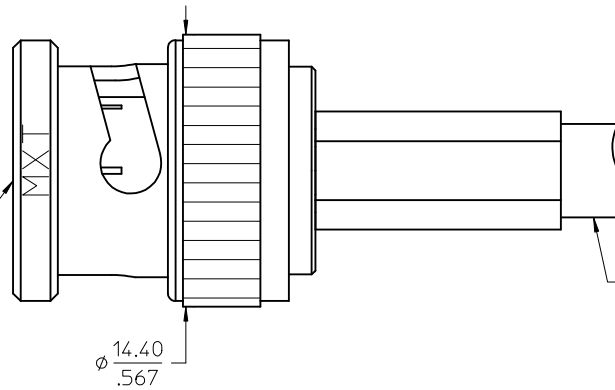

RECOMMENDED STRIP DIMENSION

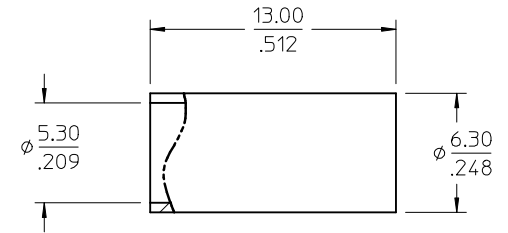

PS-89675-1030	PRODUCT SPECIFICATION
SPECIFICATION	DESCRIPTION

73171-3170	73174-0093, ONE PER BAG
73174-0093	INDIVIDUAL PLASTIC BAGS
PART NO.	PACKAGING

CHG: CONTACT REAR  
HOLE  $\phi$ .042  
WAS  $\phi$ .039  
DELETE REF FROM  
DIMENSIONS  
DELETE CABLE  
ASSEMBLY SPEC  
PS-89675-103 WAS  
PS-73598-0024

EC NO: URF2010-0237  
DRAWN: WIENER 2009/10/22  
CHKD: SHAH 2009/10/22  
APPR: WIENER 2009/10/22

QUALITY SYMBOLS  
  
 DESCRIPTION  
 REV: C2

GENERAL TOLERANCES (UNLESS SPECIFIED)

	mm	INCH
4 PLACES	$\pm$ .005	$\pm$ .0002
3 PLACES	$\pm$ .003	$\pm$ .0001
2 PLACES	$\pm$ .002	$\pm$ .0001
1 PLACE	$\pm$ .001	$\pm$ .0001

ANGULAR  $\pm$  2°

DRAFT WHERE APPLICABLE  
MUST REMAIN  
WITHIN DIMENSIONS

DIMENSION STYLE  
MM/IN

DRAWN BY DATE  
KELLY 1992/06/20

CHECKED BY DATE

APPROVED BY DATE

MATERIAL NO.  
SEE TABLE

SIZE  
C

SCALE  
DESIGN UNITS  
METRIC

THIRD ANGLE PROJECTION

TITLE  
BNC PLUG, STR FOR RG58,  
RG141 CRIMP/CRIMP, 50 OHM  
BNC-PC

MOLEX INCORPORATED

DOCUMENT NO.  
SD-73174-0093

SHEET NO.  
1 OF 1

THIS DRAWING CONTAINS INFORMATION THAT IS PROPRIETARY TO MOLEX  
INCORPORATED AND SHOULD NOT BE USED WITHOUT WRITTEN PERMISSION