

SCALE 1:2

REVISIONS

P	LTR	DESCRIPTION	DATE	DWN	APVD
	A	NEW RELEASE PER ECO-14-013277	27AUG2014	DM	DM
	A1	REVISE PER PCN E-19-014487	16SEP2019	JA	IG

1.52±0.25
 [.060±.010]
 MEASURED 6.35±0.64
 [.250±.025]
 FROM OPEN END

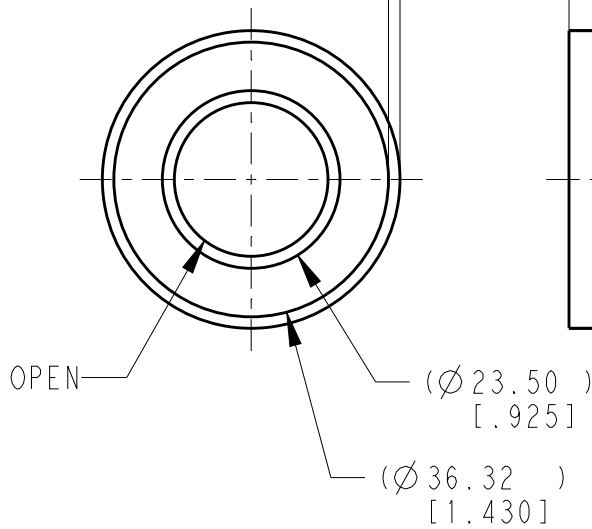
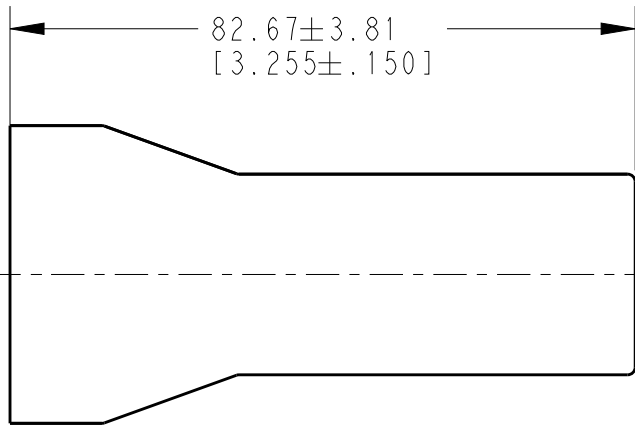

3. THIS ACCESSORY PART IS PROVIDED WITHOUT TYPICAL TRANSPORTATION INDUSTRY PROCESS CONTROLS. NO VALIDATION TESTING HAS BEEN PERFORMED. CUSTOMER IS RESPONSIBLE FOR DETERMINING PRODUCT PERFORMANCE AND SUITABILITY FOR APPLICATION.
2. TEMPERATURE RATING: -29°C TO +100°C [-20°F TO +212°F].
1. THIS PART IS USED ON
 HDP24-24-XXX RECEPTACLES
 HDP26-24-XXX PLUGS
 HD34-24-XXX RECEPTACLES
 HD36-24-XXX PLUGS
 WHERE XXX IS PIN ARRANGEMENTS.

NOTES:

TE INTERNAL PN	DEUTSCH PN
HD30-24BT-BK	HD30-24BT-BK

THIS DRAWING IS UNPUBLISHED. ALL RIGHTS RESERVED. 2019

COPYRIGHT 2014 BY TE CONNECTIVITY

DIMENSIONS:	
mm [INCHES]	
TOLERANCES UNLESS OTHERWISE SPECIFIED:	
0 PLC	±
1 PLC	±
2 PLC	±
3 PLC	±0.63 [.025]
4 PLC	±
ANGLES	±0° 30' 0"

DWN	27AUG2014
D.MEYER	
CHK	27AUG2014
I.GRANTCHAROVA	
APVD	27AUG2014
D.MEYER	
PRODUCT SPEC	
APPLICATION SPEC	
WEIGHT	11.72g

MATERIAL	PVC	FINISH	BLACK
 TE Connectivity			
NAME			
BOOT, SIZE 24			
HD30/HDP20 SERIES			
SIZE	CAGE CODE	DRAWING NO	RESTRICTED TO
A 4	4AFU8	©=HD30-24BT-BK	-

CUSTOMER DRAWING	SCALE	1:1	SHEET	1 OF 1	REV	A1
------------------	-------	-----	-------	--------	-----	----