

IR1175

Synchronous Rectifier Driver

Features

- Provides constant and proper gate drive to power MOSFETs regardless of transformer output
- Minimizes loss due to power MOSFET body drain diode conduction
- Stand alone operation - no ties to primary side
- Schmitt trigger input with double pulse suppression allows operation in noisy environments
- High peak current drive capability - 2A
- High speed operation - 2MHz
- Adaptable to multiple topologies (such as single-ended forward, double-ended forward)

Description

The IR1175 is a high speed CMOS controller designed to drive N-channel power MOSFETs used as synchronous rectifiers in high current, high frequency forward converters with output voltages equal or below 5VDC. Schmitt trigger inputs with double pulse suppression allow the controller to operate in noisy environments. The circuit does not require any ties to the primary side and derives its operating power directly from the secondary. The circuit functions by anticipating transformer output transitions, then turns the power MOSFETs on or off before the transitions of the transformer to minimize body drain diode conduction and reduce associated losses. Turn on/off lead time can be adjusted to accommodate a variety of power MOSFET sizes and circuit conditions. The IR1175 also provides gate drive overlap/dead-time control via external components to further minimize diode conduction by nulling effects of secondary loop and device package inductance.

Product Summary

V_{dd}	5Vdc
$I_{O+/-}$ (peak)	2A/2A
F_{max}	2MHz
Max lead time	500nsec

Packages

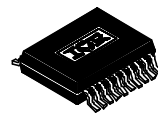

IR1175S
20 Lead Surface Mount
(SSOP-20)

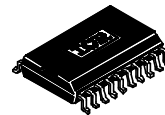

IR1175SS
20 Lead SOIC (MS-013AC)

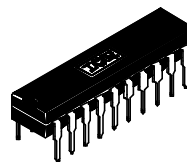

IR1175
20 Lead PDIP
(MS-001AD)

Absolute Maximum Ratings

Absolute maximum ratings indicate sustained limits beyond which damage to the device may occur.

Symbol	Definition	Min.	Max.	Units
V _{dd}	Supply voltage	—	7	V _{DC}
I _{in}	Input clamp current	—	+/- 10	mA _{DC}
P _D	Power dissipation (SSOP-20)	—	400	mW
R _{thJC}	Thermal resistance (SSOP-20) junction-to-case	—	28.5	°C/W
R _{thJA}	Thermal resistance (SSOP-20) junction-to-ambient	—	90.5	°C/W
T _J	Junction temperature	—	150	°C
T _S	Storage temperature	-55	150	°C
T _L	Lead temperature (soldering, 10 seconds)	—	300	°C

Recommended Operating Conditions

Symbol	Definition	Min.	Typ.	Max.	Units
V _{dd}	Supply voltage operating range	—	5	—	V _{DC}
T _A	Ambient temperature	-40	—	85	°C
Freq	Operating frequency	250	—	500	KHz
R _{bias}	Required bias resistor (+/- 1%)	—	69.8	—	KΩ
UV	Voltage at UVSET pin	1.75	—	2.25	V _{DC}
X _{in}	Maximum voltage at X1 and X2 inputs	—	—	5.6	V _{DC}
Cd1/Cd2	Capacitance at pins DTIN1 and DTIN2	—	—	22	pF

Dynamic Electrical Characteristics

V_{dd}=5V, T_A = 25°C, R_{bias} = 69.8K unless otherwise specified.

Symbol	Definition	Min.	Typ.	Max.	Units
V _{dd}	Supply voltage operating range	4.0	—	5.5	V _{DC}
I _{qdd}	V _{dd} quiescent current (V _{in} =0 or 5V, I _{out} =0)	—	3	5	mA _{DC}
Freq	Operating frequency	100	—	2000	KHz
UVSET+	UVSET positive going threshold	1.10	—	1.4	V
UVSET-	UVSET negative going threshold	0.8	—	1.1	V
V _{xth+}	X1/X2 Input positive going threshold	—	1.4	—	V _{DC}
V _{xth-}	X1/X2 Input negative going threshold	—	1.0	—	V _{DC}
T _{adv}	Externally adjustable lead time (advance)	—	—	500	nsec
T _d	Externally adjustable dead-time for Q1 and Q2	20	—	—	nsec
I _{sink} (peak)	Q1,Q2 output sink current (V _{dd} =5.0V, pulsed, 10 usec)	—	—	2	A
I _{source} (peak)	Q1,Q2 output source current (V _{dd} =5.0V, pulsed, 10 usec)	—	—	2	A
VOH	Q1, Q2 High level voltage (I _{out} = 20mA)	—	4.50	—	V
VOL	Q1, Q2 Low level voltage (I _{out} = 20mA)	—	1.15	—	
t _{io}	Input to output delay (PLL bypassed, cross coupled mode)	—	20	—	nsec
t _r	Gate turn-on rise time (C1=1000pf, V _{dd} =5V)	—	20	—	nsec
t _f	Gate turn-off fall time (C1=1000pf, V _{dd} =5V)	—	20	—	nsec
V _{tr}	Cross-over voltage (V _{dd} =5Vdc, DTIN shorted to DTOUT, C1=1000pf) Fig. 3	—	2.5	—	V _{DC}
R _{bias}	Required bias resistor	68	—	71	KΩ
V _{bias}	Voltage at R _{bias} pin	—	1.25	—	V _{DC}
T _{jitter}	Phase-lock loop output jitter	-20	—	20	nsec
I _{chg} pump	Charge pump output current (at VFLTR pin)	—	50	—	μA _{DC}
V _{chg} pump	Charge pump output voltage (at VFLTR pin)	1.3	1.5	1.7	V _{DC}
K _{vco_dc}	PLL V _{co} DC gain	—	62	—	KHz/ Volt

Lead Definitions and Assignments

Symbol	Description
AVDD	Power - + 5 V _{DC} to MOSFET drivers
Q1	Output - gate drive for Q1 power MOSFET
DTOUT1	Output - sets dead time for Q1 output - used with DTIN1
DTIN1	Input - sets dead time for Q1 - used with DTOUT1
RADV1	Output - sets lead time (advance) for Q1
VFLTR1	Output - PLL loop filter for Q1 output
RVCO1	Output - sets PLL center frequency for Q1 output
X1	Input - transformer input for Q1
VDD	Power - +5 Vdc for internal logic
UVSET	Input - sets UVLO+ If this pin is pulled below 1.25VDC externally, then both Q1 and Q2 outputs will be at Vss (disabled)
RBIAS	Output - connected to 69.8K +/- 1% resistor - sets operating current
AVSS	Ground for logic supply (AVDD)
X2	Input - transformer input for Q2
RVCO2	Output - sets PLL center frequency for Q2 output
VFLTR2	Output - PLL loop filter for Q2
RADV2	Output - sets lead time (advance) for Q2
DTIN2	Input - sets dead time for Q2 - used with DTOUT2
DTOUT2	Output - sets dead time for Q2 - used with DTIN2
VSS	Ground for MOSFET driver supply (VDD)
Q2	Output - gate drive for Q2 power MOSFET

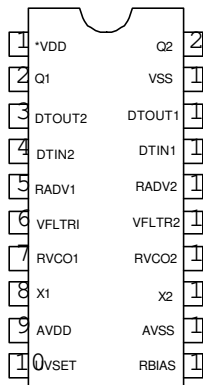

IR1175S
(SSOP-20)

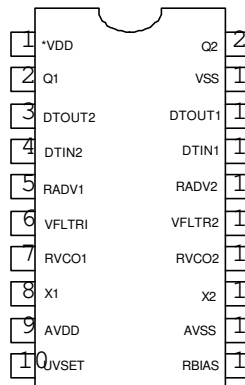

IR1175SS
SOIC (wide body)

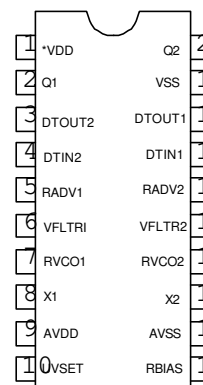

IR1175
PDIP

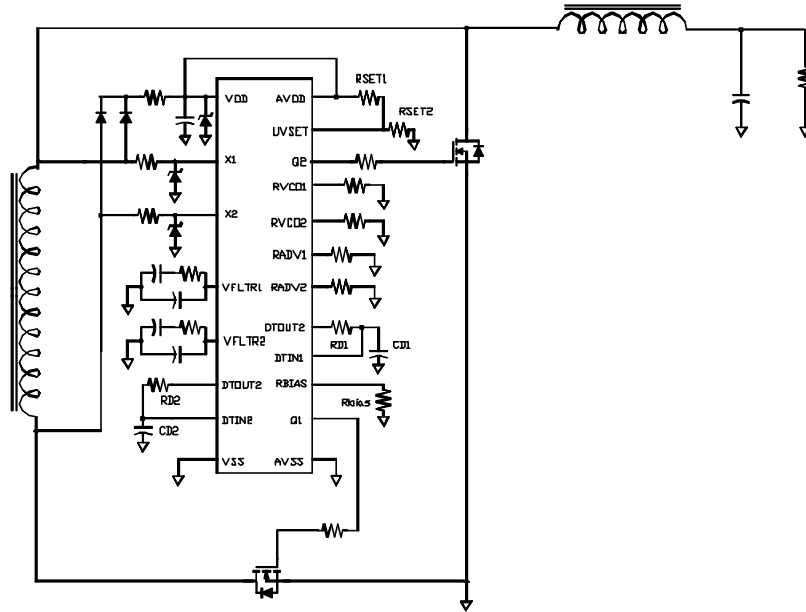

Fig. 1 Typical application circuit when supply $V_{out} < 5.0 V_{DC}$

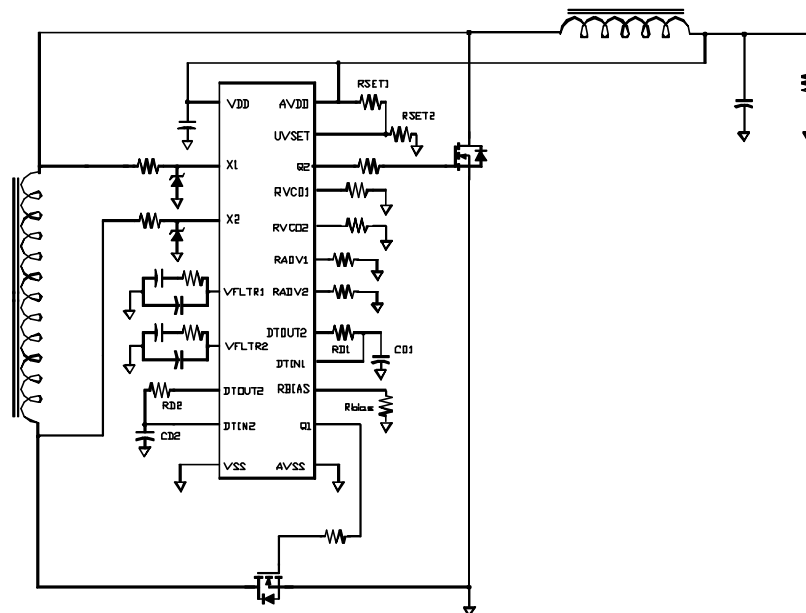

Fig. 2 Typical application circuit when supply $V_{out} = 5.0 V_{DC}$

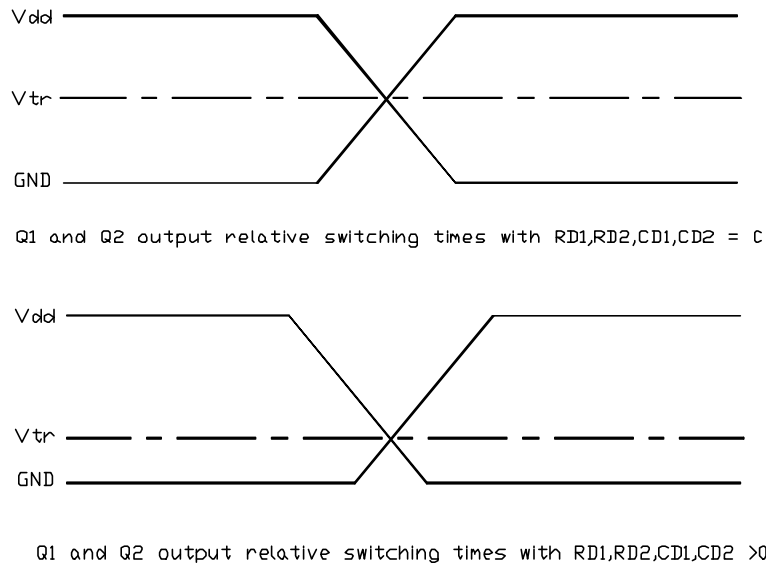

Fig. 3 Gate drive characteristics and definitions

Phase Lock Loop Design Equations:

1 - Resistor to set VCO Center Frequency:

$$R_{vco} (K\Omega) = 143 \times [V_{chgpump}(V_{DC}) / f_{vco}(KHz)] \times K_{vco_dc}(KHz/Volt)$$

Example (A): Choose $V_{chgpump} = 1.5V$, desired frequency (f_{vco}) = 300KHz

$$R_{vco} = 143 \times [1.5 / 300] \times 62 \text{ Hz/Volt} = 44.33 \text{ K}\Omega$$

2 - Small Signal gain for VCO:

$$K_{vco_ac} (KHz/Volt) = 1E3 \times K_{vco_dc} (KHz/Volt) / (7 \times R_{vco}(K\Omega))$$

Example (B): Choosing same conditions as in example A:

$$K_{vco_ac} = 1E3 \times 62 / (7 \times 44.33) = 199.9 \text{ KHz/volt}$$

3 -PLL Natural frequency:

$$\omega_n = 2\pi f_n(\text{KHz}) = \sqrt{I_{\text{chpump}}(\mu\text{A}) \times K_{\text{vco_ac}}(\text{KHz/V}) / C(\text{nF})}$$

Choose Cf such that $C_f = C/16$

4 -PLL Damping factor calculations:

$$P = \pi E^{-3} \times R_f(\text{KOhms}) \times C(\text{nF}) \times f_n(\text{KHz})$$

Typical value for P is 0.707. (Critically damped)

5 -Advance timing:

$$T_{\text{adv}}(\text{nsec}) = R_{\text{ADV}}(\text{KOhms}) \times 10^{-10}$$

Where R_{ADV} is resistance from R_{ADV1} or R_{ADV2} to ground.

Example C: R_{ADV}=10Kohms will result in T_{adv}=10*10⁻¹⁰=90 nsec .

6-Dead time calculations:

$$T_d(\text{nsec}) = 0.69 \times R_{\text{dt}}(\text{KOhms}) \times C_{\text{dt}}(\text{pF}) + 5 \quad (\text{For } V_{\text{dd}}=5 \text{ V})$$

Where R_{dt} is resistance between pins DTIN1 and DTOUT1 or DTIN2 and DTOUT2 .C_{dt} is capacitance from DTIN1 or DTIN2 to ground.

Example D: R_{dt}=10Kohms and C_{dt}=22pF will result in: T_d=156.8 nsec

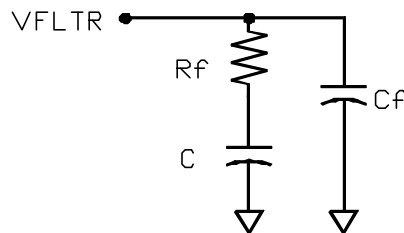

Fig. 4 PLL loop filter component definitions

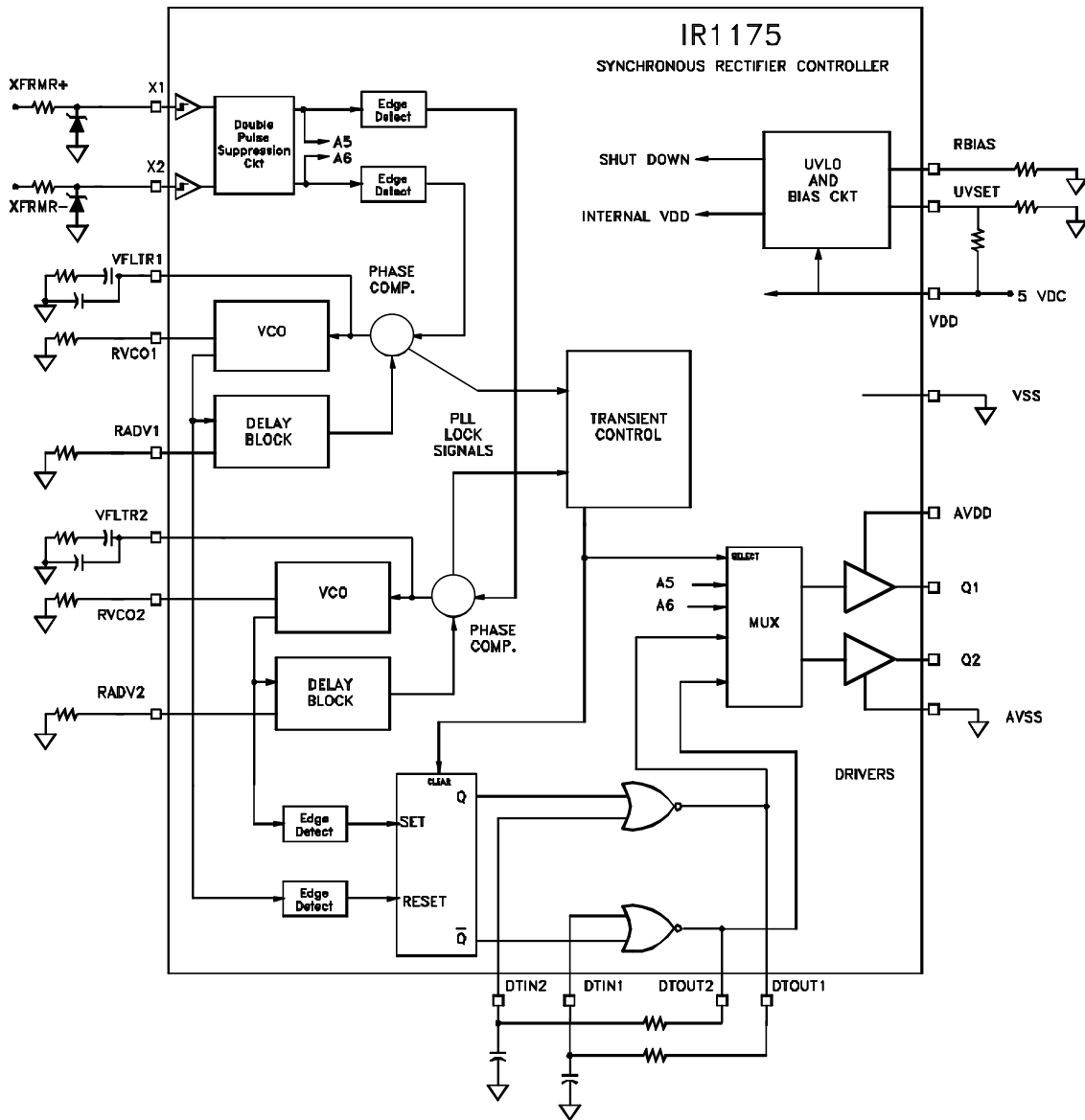

Fig. 5 IR1175 Block Diagram

Case Outline

SYMBOL	M0-150AE DIMENSIONS					
	MILLIMETERS			INCHES		
	MIN	NOM	MAX	MIN	NOM	MAX
A	---	---	2.00	---	---	.078
A1	0.05	---	---	.002	---	---
A2	1.85	1.75	1.85	.065	.069	.072
b	0.22	---	0.38	.009	---	.014
c	0.09	---	0.25	.004	---	.009
D	6.90	7.20	7.50	.272	.283	.295
E	7.80 BSC			.307 BSC		
E1	5.00	5.30	5.60	.197	.209	.220
e	0.65 BSC			0.26 BSC		
L	0.55	0.75	0.95	.022	.029	.037
L1	0.25 BSC			.010 BSC		
B	D*	4*	8*	0*	4*	8*
aaa	0.10			.004		
bbb	0.15			.006		
ccc	0.20			.008		

NOTES

- DIMENSIONING AND TOLERANCING PER ASME Y14.5M-1994.
- DIMENSIONS ARE SHOWN IN MILLIMETERS AND INCHES.
- CONTROLLING DIMENSION; MILLIMETER.
- DATUM PLANE H IS LOCATED AT THE MOLD PARTING LINE.
- DATUM A AND B TO BE DETERMINED AT DATUM PLANE H.
- DIMENSIONS D AND E1 DO NOT INCLUDE PROTRUSIONS AND ARE MEASURED AT DATUM PLANE H. PROTRUSIONS SHALL NOT EXCEED 0.20 [0.008] PER SIDE
- DIMENSION L IS THE LEAD LENGTH FOR SOLDERING TO A SUBSTRATE.
- OUTLINE CONFORMS TO JEDEC OUTLINE M0-150AE.

20 Lead Surface Mount (SSOP-20)

01-6057 00
01-3078 00 (MS013AC)

Case Outline

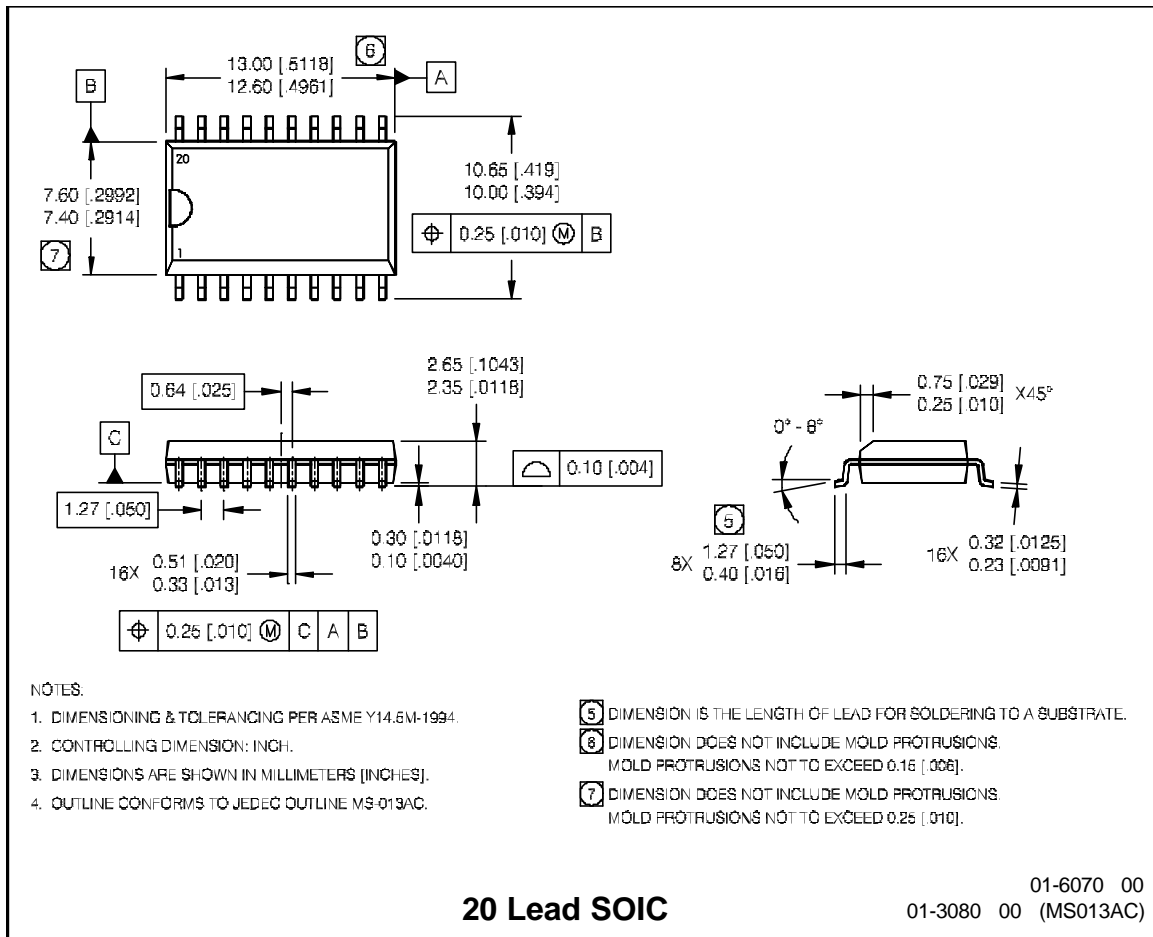

Case Outline

