

Customer Information Sheet

DRAWING No.: M80-791XXXX

SHEET 2 OF 2

IF IN DOUBT - ASK

©

NOT TO SCALE

THIRD ANGLE PROJECTION

ALL DIMENSIONS IN mm

ORDER CODE:

M80-791XXXX

TOTAL No. OF CONTACTS:

04, 06, 08, 10, 12, 14,
16, 18, 20, 26, 34, 44

FINISH:

22 - GOLD ON CONTACT AREA
TIN/LEAD ON TAILS
42 - GOLD ON CONTACT AREA
100% TIN ON TAILS
45 - GOLD

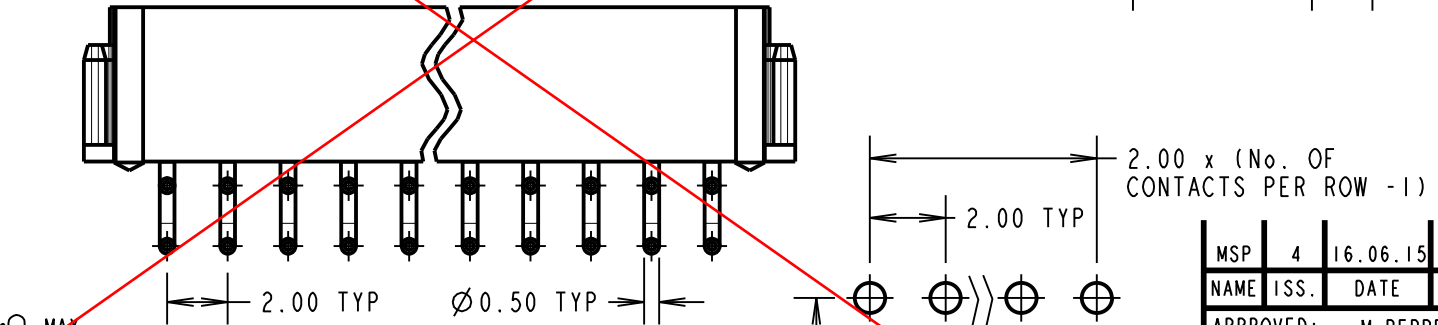
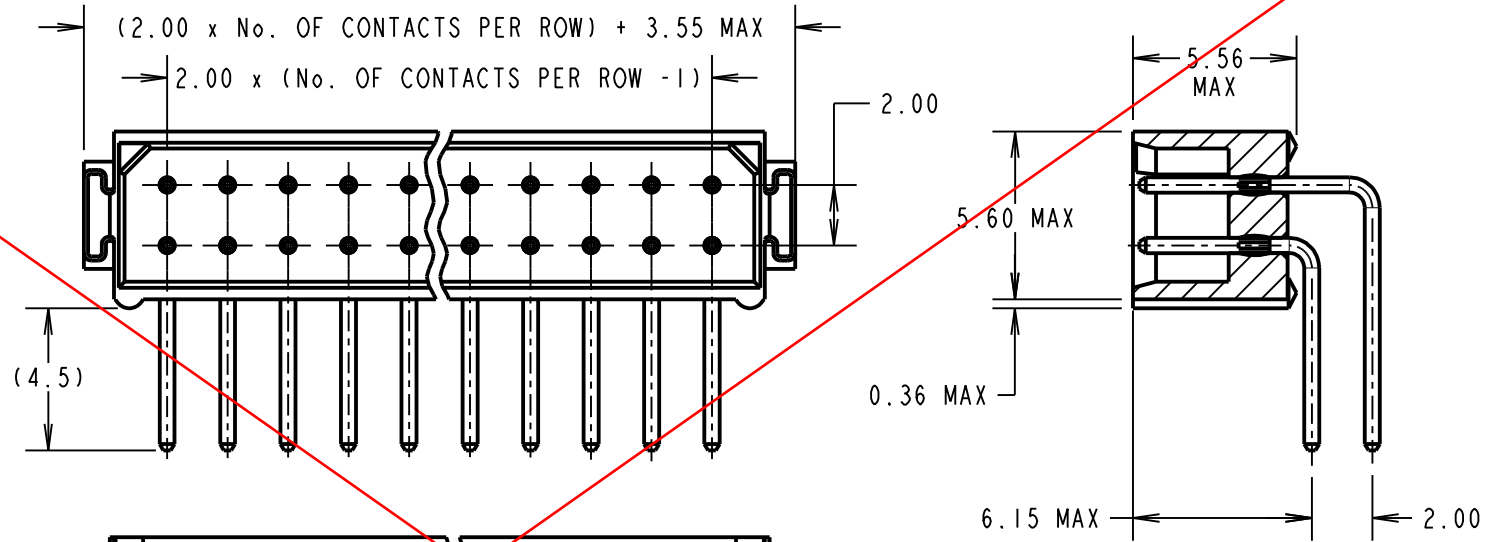

SPECIFICATIONS:

MATERIAL:

MOULDING = POLYAMIDE 46 UL94V-0, BLACK
CONTACTS = PHOSPHOR BRONZE

FINISH:

CONTACTS:

22 = 0.75µ GOLD ON CONTACT AREA,
3.0µ TIN/LEAD ON TAILS
42 = 0.75µ GOLD ON CONTACT AREA,
3.0µ 100% TIN ON TAILS
45 = 0.75µ GOLD

ELECTRICAL:

CURRENT RATING (25°C) = 3.3A MAX.
CURRENT RATING (85°C) = 2.6A MAX.
WORKING VOLTAGE = 800V AC/DC
VOLTAGE PROOF = 1200V AC/DC
CONTACT RESISTANCE (INITIAL) = 20mΩ MAX.
CONTACT RESISTANCE (AFTER CONDITIONING) = 25mΩ MAX.
INSULATION RESISTANCE (INITIAL) = 1000MΩ MIN.
INSULATION RESISTANCE (AFTER CONDITIONING) = 100MΩ MIN.

MECHANICAL:

DURABILITY = 500 OPERATIONS

ENVIRONMENTAL:

TEMPERATURE RANGE = -55°C TO +125°C

PACKING:

TUBE

FOR COMPLETE SPECIFICATION, SEE COMPONENT SPECIFICATION C005XX (LATEST ISSUE)

OBSOLETE

NOTES:

1. 2-OFF STRAIN RELIEF STRAPS
M80-0030006 ARE INCLUDED
WITH EACH CONNECTOR.

MSP	4	16.06.15	12965
NAME	ISS.	DATE	C/NOTE
APPROVED:		M.PERREN	
CHECKED:		S.BENNETT	
DRAWN:		JM BROOKES	
CUSTOMER REF.:			
ASSEMBLY DRG:			

HARWIN

www.harwin.com
technical@harwin.com

THIS DRAWING AND ANY INFORMATION OR DESCRIPTIVE MATTER SET OUT HEREON ARE CONFIDENTIAL AND COPYRIGHT PROPERTY OF THE HARWIN GROUP AND MUST NOT BE DISCLOSED, LOANED, COPIED OR USED FOR MANUFACTURING, TENDERING OR FOR ANY OTHER PURPOSE WITHOUT THEIR WRITTEN PERMISSION.

TOLERANCES

X. = ±1mm
X.X = ±0.50mm
X.XX = ±0.10mm
X.XXX = ±0.01mm
ANGLES = ±5°
UNLESS STATED

MATERIAL:

SEE ABOVE

FINISH: SEE ABOVE

S/AREA:

mm²

TITLE:

DATAMATE DIL
HORIZONTAL MALE PC TAIL
ASSEMBLY - UNLATCHED

DRAWING NUMBER:

M80-791XXXX

SHT
2 OF 2