

# Customer Information Sheet

DRAWING No.: M80-4C100F2-50-327

SHEET 2 OF 2

IF IN DOUBT - ASK

©

NOT TO SCALE

THIRD ANGLE PROJECTION

ALL DIMENSIONS IN mm

## SPECIFICATIONS:

**MATERIAL:**  
 MOULDING: GLASS FILLED PPS, UL94V-0, BLACK  
**POWER CONTACT:**  
 BODY = COPPER ALLOY  
 LATCHING COLLAR = BERYLLIUM COPPER  
 JACKSCREW, CIRCLIP: STAINLESS STEEL  
**FINISH:**  
 POWER CONTACT:  
 BODY = GOLD  
 LATCHING COLLAR = NICKEL  
**ELECTRICAL:**  
 WORKING VOLTAGE = 120V AC/DC  
 VOLTAGE PROOF = 360V AC/DC  
 INSULATION RESISTANCE = 100MΩ MIN  
 POWER CONTACT:  
 CONTACT RESISTANCE = 6 mΩ MAX  
 CURRENT RATING = 10A MAX WITH 16AWG  
 CONTACT AS SPECIFIED  
**MECHANICAL:**  
 DURABILITY = 500 OPERATIONS  
 POWER CONTACT:  
 INSERTION FORCE = 5N MAX  
 WITHDRAWAL FORCE = 0.5N MIN  
**ENVIRONMENTAL:**  
 TEMPERATURE RANGE = -55°C TO +125°C  
**PACKING:**  
 BAG  
 FOR COMPLETE SPECIFICATION SEE COMPONENT  
 SPECIFICATION C005XX (LATEST ISSUE)

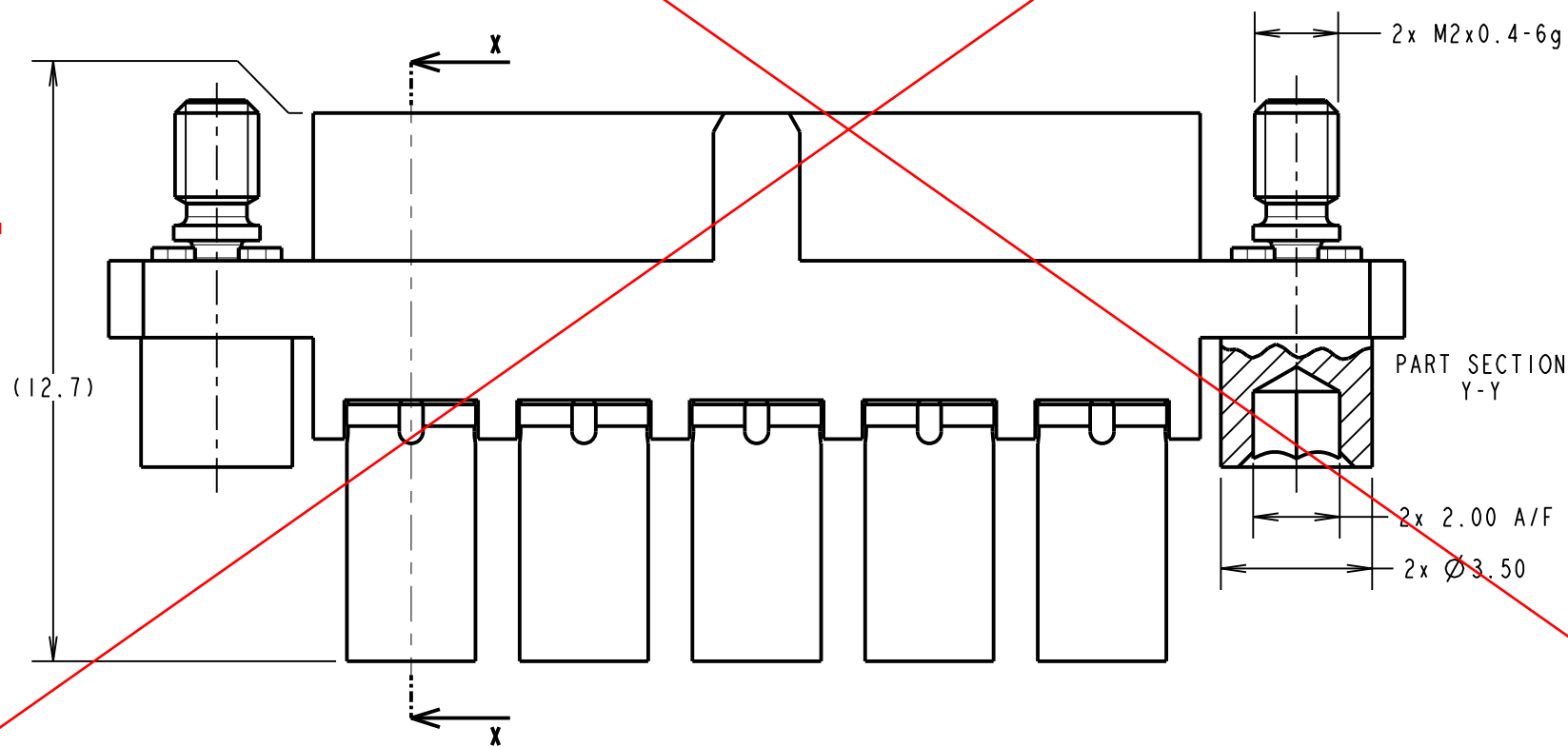
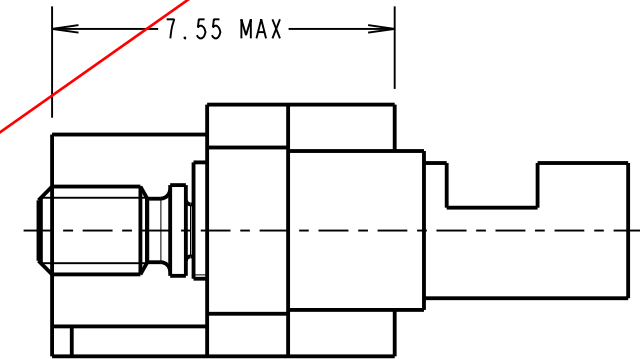
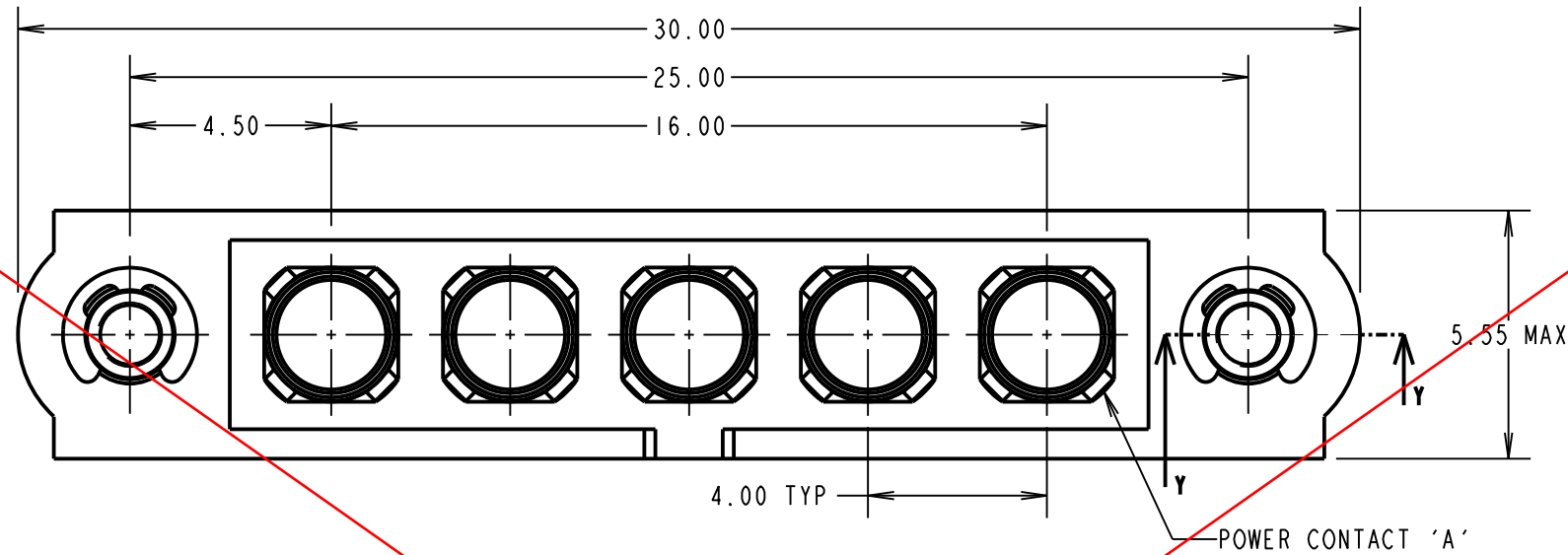

SECTION X-X

PART SECTION Y-Y

**OBSOLETE**

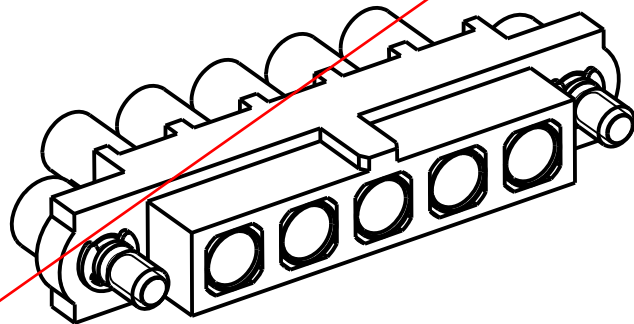

### NOTES:

- CONNECTORS ARE SUPPLIED WITH CONTACTS LOOSE.
- FOR EXTRA POWER CONTACTS, USE PART NUMBER M80-327
- POWER CONTACT WIRE, STRIP BY 5.00mm MINIMUM
- POWER CONTACT EXTRACTION TOOL = Z80-290
- INSTRUCTION SHEETS ARE AVAILABLE.

SM	1	25.08.10	10806
NAME	ISS.	DATE	C/NOTE
APPROVED: S. MCCULLAGH			
CHECKED: R. ADDE			
DRAWN: J.M. BROOKES			
CUSTOMER REF.:			
ASSEMBLY DRG:			

<b>HARWIN</b>		
HARWIN USA TEL: 603 893 5376 FAX: 603 893 5396 mis@harwin.com	HARWIN Europe (UK) TEL: 023 9231 4545 FAX: 023 9231 4590 mis@harwin.co.uk	HARWIN Asia TEL: +65 6 779 4909 FAX: +65 6 779 3868 mis@harwin.com.sg

THIS DRAWING AND ANY INFORMATION OR DESCRIPTIVE MATTER SET OUT HEREON ARE CONFIDENTIAL AND COPYRIGHT PROPERTY OF THE HARWIN GROUP AND MUST NOT BE DISCLOSED, LOANED, COPIED OR USED FOR MANUFACTURING, TENDERING OR FOR ANY OTHER PURPOSE WITHOUT THEIR WRITTEN PERMISSION.

**TOLERANCES**  
 X. = ±1mm  
 X.X = ±0.25mm  
 X.XX = ±0.10mm  
 X.XXX = ±0.01mm  
 ANGLES = ±5°  
 UNLESS STATED

**MATERIAL:**  
 SEE ABOVE  
**FINISH:**  
 SEE ABOVE  
**S/AREA:**  
 mm<sup>2</sup>

**TITLE:** JACKSCREW DATAMATE  
 MIXED TECHNOLOGY VERTICAL  
 CRIMP FEMALE ASSEMBLY  
**DRAWING NUMBER:**  
 M80-4C100F2-50-327  
 SHT 2 OF 2