

Model 402W

IoT Enhanced Quartz Crystal

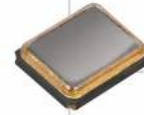

Part Dimensions:
2.0 × 1.6 × 0.55mm • 5.7002mg

Features

- Optimized Design for Low Plating Capacitance and ESR
- Improves Start-Up and Power Savings for Low Energy Applications
- Hermetic Ceramic Surface Mount Package
- Fundamental Crystal Design
- Frequency Range 16 – 80MHz
- Operating Temperature Range to -40°C to +125°C
- Tape and Reel Packaging, EIA-481

Standard Frequencies – see Page 5 for developed frequencies.
* Check with factory for availability of frequencies not listed.

Applications

- Wireless Communications
- Low Power MCUs, SoCs, RF ICs
- M2M Communications
- WiFi, ZigBee, ZigBee RF4CE, Z-Wave
- Bluetooth, Bluetooth Low Energy
- LoRa, LPWAN, 6LowPan, WLAN
- Near Field Communication
- Low Drive Chipsets
- ISM Band Applications

Description

CTS Model 402W incorporates a high Q quartz resonator and has optimized design parameters for Low ESR and Load Capacitance [C_L]. M402W is ideal for supporting commercial and industrial IoT applications using low power MCUs, portable RF communication ICs and low drive chipsets.

Ordering Information

Model	Mode of Oscillation	Frequency Code [MHz]	Tolerance @ +25°C	Temperature Stability	Temperature Range	Load Capacitance	Packaging																																											
402W	F	XXX	3	5	C	D	R																																											
	<table border="1"> <thead> <tr> <th>Code</th> <th>Mode</th> </tr> </thead> <tbody> <tr> <td>F</td> <td>Fundamental</td> </tr> </tbody> </table>	Code	Mode	F	Fundamental		<table border="1"> <thead> <tr> <th>Code</th> <th>Tolerance</th> </tr> </thead> <tbody> <tr> <td>1</td> <td>±10ppm</td> </tr> <tr> <td>X</td> <td>±15ppm</td> </tr> <tr> <td>2</td> <td>±20ppm</td> </tr> <tr> <td>Y</td> <td>±25ppm</td> </tr> <tr> <td>3</td> <td>±30ppm</td> </tr> </tbody> </table>	Code	Tolerance	1	±10ppm	X	±15ppm	2	±20ppm	Y	±25ppm	3	±30ppm		<table border="1"> <thead> <tr> <th>Code</th> <th>Temp. Range</th> </tr> </thead> <tbody> <tr> <td>C</td> <td>-20°C to +70°C²</td> </tr> <tr> <td>D</td> <td>-30°C to +85°C²</td> </tr> <tr> <td>I</td> <td>-40°C to +85°C³</td> </tr> <tr> <td>G</td> <td>-40°C to +105°C⁴</td> </tr> <tr> <td>H</td> <td>-40°C to +125°C⁵</td> </tr> </tbody> </table>	Code	Temp. Range	C	-20°C to +70°C ²	D	-30°C to +85°C ²	I	-40°C to +85°C ³	G	-40°C to +105°C ⁴	H	-40°C to +125°C ⁵		<table border="1"> <thead> <tr> <th>Code</th> <th>Packing</th> </tr> </thead> <tbody> <tr> <td>R</td> <td>3k pcs./reel</td> </tr> </tbody> </table>	Code	Packing	R	3k pcs./reel											
Code	Mode																																																	
F	Fundamental																																																	
Code	Tolerance																																																	
1	±10ppm																																																	
X	±15ppm																																																	
2	±20ppm																																																	
Y	±25ppm																																																	
3	±30ppm																																																	
Code	Temp. Range																																																	
C	-20°C to +70°C ²																																																	
D	-30°C to +85°C ²																																																	
I	-40°C to +85°C ³																																																	
G	-40°C to +105°C ⁴																																																	
H	-40°C to +125°C ⁵																																																	
Code	Packing																																																	
R	3k pcs./reel																																																	
		<table border="1"> <thead> <tr> <th>Code</th> <th>Frequency</th> </tr> </thead> <tbody> <tr> <td colspan="2">Product Frequency Code¹</td> </tr> </tbody> </table>	Code	Frequency	Product Frequency Code ¹			<table border="1"> <thead> <tr> <th>Code</th> <th>Stability</th> <th>Code</th> <th>Stability</th> </tr> </thead> <tbody> <tr> <td>1</td> <td>±10ppm</td> <td>3</td> <td>±30ppm</td> </tr> <tr> <td>X</td> <td>±15ppm</td> <td>5</td> <td>±50ppm</td> </tr> <tr> <td>2</td> <td>±20ppm</td> <td>6</td> <td>±100ppm</td> </tr> <tr> <td>Y</td> <td>±25ppm</td> <td></td> <td></td> </tr> </tbody> </table>	Code	Stability	Code	Stability	1	±10ppm	3	±30ppm	X	±15ppm	5	±50ppm	2	±20ppm	6	±100ppm	Y	±25ppm				<table border="1"> <thead> <tr> <th>Code</th> <th>Capacitance</th> <th>Code</th> <th>Capacitance</th> </tr> </thead> <tbody> <tr> <td>M</td> <td>4pF</td> <td>K</td> <td>8pF</td> </tr> <tr> <td>W</td> <td>5pF</td> <td>J</td> <td>9pF</td> </tr> <tr> <td>T</td> <td>6pF</td> <td>A</td> <td>10pF</td> </tr> <tr> <td>V</td> <td>7pF</td> <td>L</td> <td>12pF</td> </tr> </tbody> </table>	Code	Capacitance	Code	Capacitance	M	4pF	K	8pF	W	5pF	J	9pF	T	6pF	A	10pF	V	7pF	L	12pF
Code	Frequency																																																	
Product Frequency Code ¹																																																		
Code	Stability	Code	Stability																																															
1	±10ppm	3	±30ppm																																															
X	±15ppm	5	±50ppm																																															
2	±20ppm	6	±100ppm																																															
Y	±25ppm																																																	
Code	Capacitance	Code	Capacitance																																															
M	4pF	K	8pF																																															
W	5pF	J	9pF																																															
T	6pF	A	10pF																																															
V	7pF	L	12pF																																															

Notes:

- 1] Refer to document 016-1454-0, Frequency Code Tables. 3-digits for frequencies <100MHz.
- 2] Available with all stability codes.
- 3] Available with stability codes X, 2, Y, 3, 5 and 6.
- 4] Available with stability codes 3, 5 and 6.
- 5] Available with stability codes 5 and 6. Contact factory for availability.

**Not all performance combinations and frequencies may be available.
Contact your local CTS Representative or CTS Customer Service for availability.**

This product is specified for use only in standard commercial applications. Supplier disclaims all express and implied warranties and liability in connection with any use of this product in any non-commercial applications or in any application that may expose the product to conditions that are outside of the tolerances provided in its specification.



Electrical Specifications

Operating Conditions

PARAMETER	SYMBOL	CONDITIONS	MIN	TYP	MAX	UNIT
Operating Temperature	T _A	-	-20		+70	°C
			-30		+85	
			-40	+25	+85	
			-40		+105	
			-40		+125	
Storage Temperature	T _{STG}	-	-55	-	+125	°C

Frequency Stability

PARAMETER	SYMBOL	CONDITIONS	MIN	TYP	MAX	UNIT
Frequency Range	f ₀	-		16 - 80		MHz
Frequency Tolerance	Δf/f ₀	@ +25°C		10, 15, 20, 25 or 30		±ppm
Frequency Stability	Δf/f ₂₅	Referenced to +25°C reading		10, 15, 20, 25, 30, 50 or 100		±ppm
Aging	Δf/f ₀	Typical per year @ +25°C	-3	±2	3	ppm

Crystal Parameters

PARAMETER	SYMBOL	CONDITIONS	MIN	TYP	MAX	UNIT
Operating Mode	-	-		Fundamental		-
Crystal Cut	-	-		AT-Cut Strip		-
Load Capacitance	C _L	-		See Ordering Information		pF
Shunt Capacitance	C ₀	-	-	1.0	<3.0	pF
Series Resistance						
Fundamental	R ₁	16MHz - <18MHz	-	100	150	Ω
		18MHz - <21MHz	-	80	100	
		21MHz - <30MHz	-	60	80	
		30MHz - <38MHz	-	30	60	
		38MHz - 80MHz	-	25	50	
Drive Level	DL	-	-	10	100	μW
Insulation Resistance	R _i	+100Vdc ±15Vdc	500	-	-	MΩ

Δf/f₀ - Frequency deviation referenced to nominal frequency.

Δf/f₂₅ - Frequency deviation over operating temperature range, referenced to +25°C frequency.

Mechanical Specifications

Package Drawing

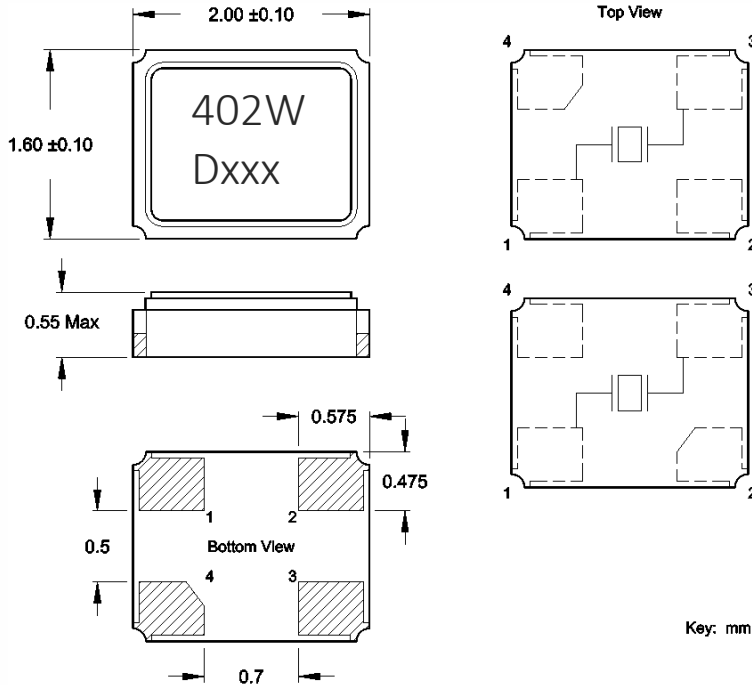

Marking Information

1. 402W – CTS model.
2. D – Date Code. See Table I for codes.
3. xxx – Frequency Code, 3-digits for frequencies below 100MHz.
[See document 016-1454-0, Frequency Code Tables.]

Recommended Pad Layout

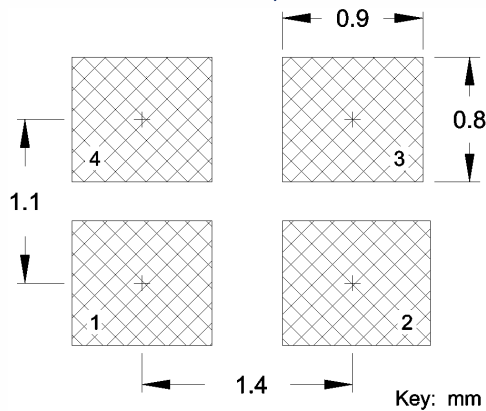

Notes

1. JEDEC termination code (e4). Barrier-plating is nickel [Ni] with gold [Au] flash plate.
2. Terminations #2, #4 and the metal lid are connected internally. End user may connect these pins to circuit ground for EMI suppression.
3. Due to package variability, the pad chamfer on the bottom could be located on Pin 2 or 4 in a given lot. Layout orientation should be based on the top view [marking side], as indicated in package drawing. The chamfer location does not affect the electrical performance of the device.
4. Reflow conditions per JEDEC J-STD-020; +260°C maximum, 20 seconds.
5. MSL = 1.

Table I - Date Code, Beginning year 2021

MONTH					JAN	FEB	MAR	APR	MAY	JUN	JUL	AUG	SEP	OCT	NOV	DEC
YEAR																
2021	2025	2029	2033	2037	A	B	C	D	E	F	G	H	J	K	L	M
2022	2026	2030	2034	2038	N	P	Q	R	S	T	U	V	W	X	Y	Z
2023	2027	2031	2035	2039	a	b	c	d	e	f	g	h	j	k	l	m
2024	2028	2032	2036	2040	n	p	q	r	s	t	u	v	w	x	y	z

Packaging - Tape and Reel

Tape Drawing

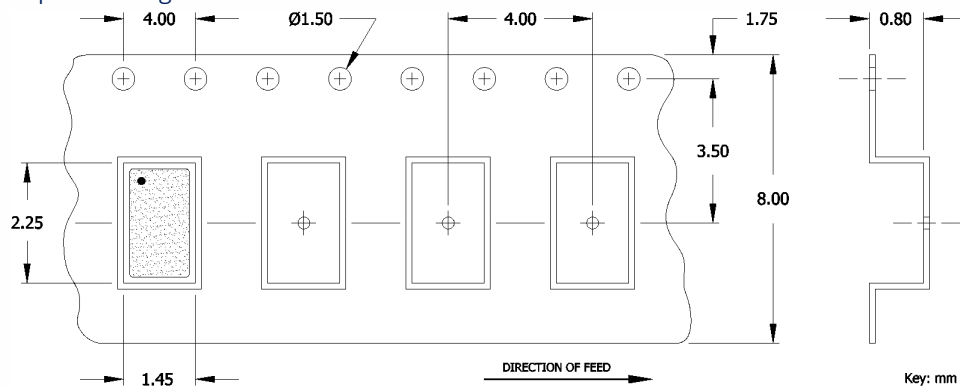

Reel Drawing

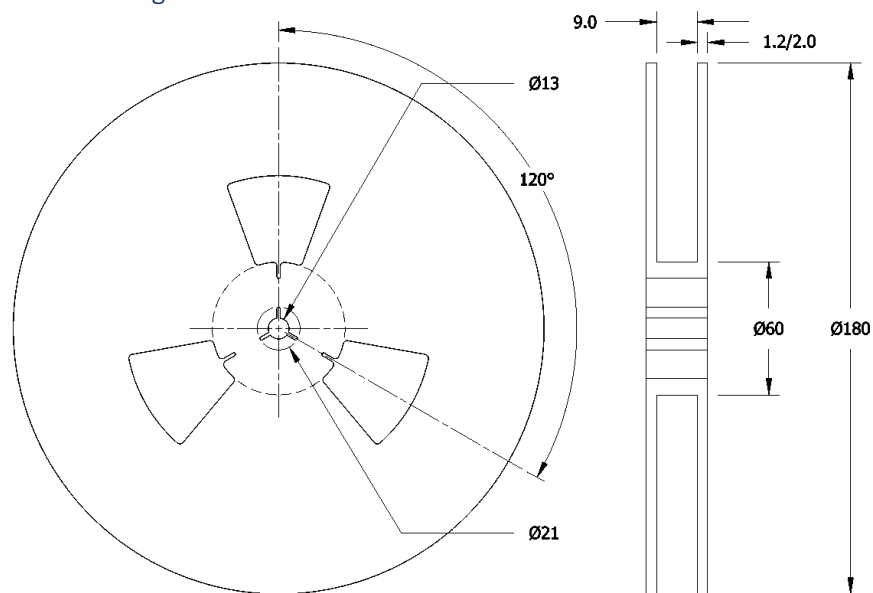

Notes

1. Device quantity is 1k pieces minimum and 3k pieces maximum per 180mm reel.
2. Complete CTS part number, frequency value, date code and manufacturing site code information must appear on reel and carton labels.



Addendum

Common Frequencies and Frequency Codes – MHz

Common Wireless Frequencies		Additional Frequencies					
FREQUENCY	FREQUENCY CODE	FREQUENCY	FREQUENCY CODE	FREQUENCY	FREQUENCY CODE	FREQUENCY	FREQUENCY CODE
16.000000	160	16.367600	16E	26.041660	26F	39.062500	39A
19.200000	192	16.384000	163	27.000000	270	41.600000	41C
20.000000	200	16.666700	16N	28.224000	282	44.000000	440
24.000000	240	16.800000	168	28.322000	28C	45.000000	450
25.000000	250	16.934400	169	28.375000	283	49.152000	491
26.000000	260	18.000000	180	28.636360	286	50.000000	500
27.120000	271	18.432000	184	29.491200	29B	54.000000	540
30.000000	300	19.440000	194	30.400000	304		
32.000000	320	19.660800	19B	30.720000	307		
37.400000	374	19.680000	196	31.250000	312		
38.400000	384	20.480000	204	32.768000	327		
40.000000	400	20.736000	207	33.000000	330		
48.000000	480	22.118400	221	33.330000	333		
52.000000	520	22.579200	225	33.333000	33E		
		24.305000	243	33.333300	33A		
		24.545400	24F	33.868800	338		
		24.545454	24G	35.328000	353		
		24.553500	24B	36.000000	360		
		24.576000	24C	38.000000	380		
		25.000625	25A	38.880000	388		