

THE INFORMATION CONTAINED HEREIN IS CONSIDERED "PROPRIETARY" TO BEL FUSE INC. AND SHALL NOT BE COPIED, REPRODUCED OR DISCLOSED WITHOUT THE WRITTEN APPROVAL OF BEL FUSE INC.

LED1 POLARITY			LED2 POLARITY		
PIN 7	PIN 8	COLOR	PIN 9	PIN 10	COLOR
-	+	YELLOW	+	-	ORANGE
/	/	/	-	+	GREEN

SCHEMATIC



ELECTRICAL CHARACTERISTICS @ 25°C

<p> URNS RATIO TX 1CT : 1 RX 1CT : 1 DCL @ 100kHz/100mVRMS 8mA DC BIAS 350µH MIN. INS. LOSS 1MHz TO 100MHz -1.0 dB MAX RET. LOSS (MIN) 1MHz-30MHz -18 dB 30MHz-60MHz -18+20LOG(F/30MHz) dB 60MHz-80MHz -12 dB CROSS TALK (TX - RX) 500kHz-1MHz -70 dB MIN 10 MHz -50 dB MIN 30 MHz -45 dB MIN 50 MHz -40 dB MIN 100 MHz -35 dB MIN CM TO CM REJ 100kHz-1MHz -70 dB MIN 10 MHz -47 dB MIN 30 MHz -42 dB MIN 60 MHz -37 dB MIN 100 MHz -30 dB MIN CM TO DM REJ 100kHz-1MHz -70 dB MIN 10 MHz -60 dB MIN 30 MHz -50 dB MIN 60 MHz -45 dB MIN 100 MHz -40 dB MIN HIPOT (Isolation Voltage): 100% OF PRODUCTION TESTED TO COMPLY WITH IEEE 802.3 ISOLATION REQUIREMENTS. 1500 Vrms LED1 VF (FORWARD VOLTAGE) IF=20mA YELLOW 2.1V TYP. λD (DOMINANT WAVELENGTH) IF=20mA YELLOW 590nm TYP. LED 2 VF (FORWARD VOLTAGE) IF=20mA ORANGE 2.0V TYP. GREEN 2.2V TYP. λD (DOMINANT WAVELENGTH) IF=20mA ORANGE 605nm TYP. GREEN 570nm TYP. OPERATING TEMPERATURE: -40°C TO +85°C. </p>

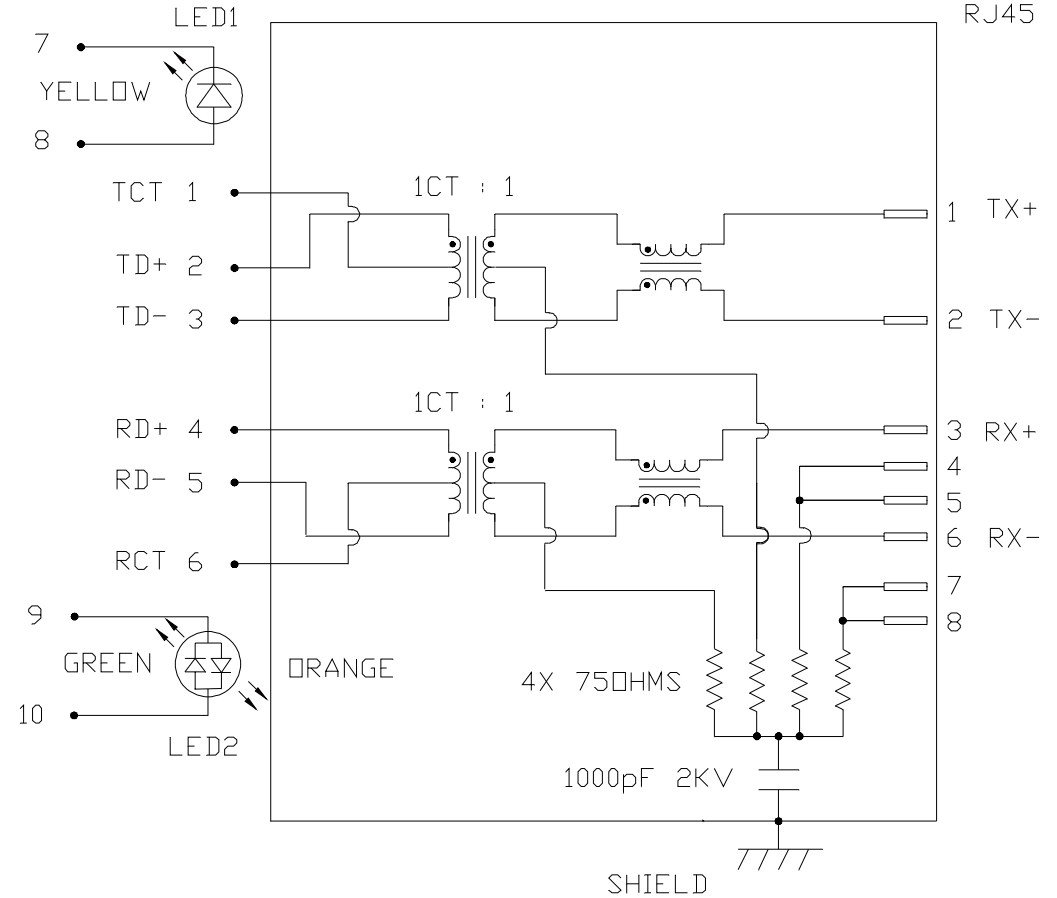

REV. : E PAGE : 2

ORIGINATED BY
CHOW WANCHUNG
DATE 2018-03-18
DRAWN BY
XIE YIMING
DATE 2018-03-18

TITLE
MagJack®
(4 Cores, MDIX, CM Termination)
08B0-1X1T-36-F

PART NO. / DRAWING NO.
08B01X1T36-F
FILE NAME
08B01X1T36-F_E.DWG

STANDARD DIM. TOL. IN INCH
.X
.XX
.XXX
[] METRIC DIM. AS REF.
UNIT : INCH [mm]
SCALE : N/A
SIZE : A4



THE INFORMATION CONTAINED HEREIN IS CONSIDERED "PROPRIETARY" TO BEL FUSE INC. AND SHALL NOT BE COPIED, REPRODUCED OR DISCLOSED WITHOUT THE WRITTEN APPROVAL OF BEL FUSE INC.

MECHANICAL SPECIFICATION

RoHS

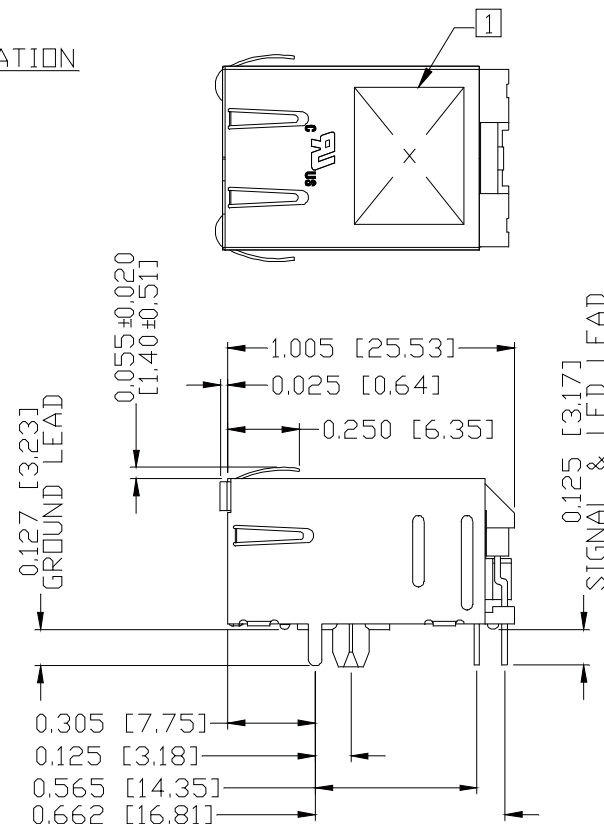
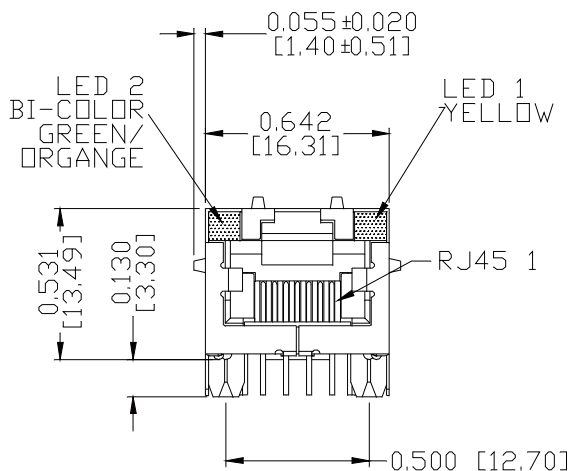

NOTES:

- PLASTIC HOUSING: THERMOPLASTIC PBT, BLACK
FLAMMABILITY RATING UL 94V-0
- CONTACTS PLATING: 15 MICRO-INCH HARD GOLD PLATING OR EQUIVALENT
- PINS: TIN-COATED COPPER WIRE, DIA 0.018 INCH.
100 MICRO-INCH MIN MATTE TIN. PINS ARE SOLDER DIPPED.
- METAL SHIELD: PRE-PLATED NICKEL ON COPPER ALLOY.
(ALL GROUND LEADS ARE SOLDER DIPPED)
- MARK PART WITH MFG LOGO, MFG NAME, PART NUMBER AND DATE CODE.

- 5. THE PART IS RECOMMENDED FOR WAVE SOLDERING. THE SUGGESTED PEAK WAVE SOLDERING CONDITION IS 260°C MAX AND 10 SECONDS MAX.

- 1. UL RECOGNIZED - FILE #E196366 AND E169987.
- 2. THE PRODUCT IS RoHS COMPLIANT.
- 3. JACK CAVITY CONFORMS TO FCC RULES AND REGULATIONS, PART 68 SUBPART F.

ORIGINATED BY
ANTON LIAO
DATE 2018-03-18
DRAWN BY
JESSE LI
DATE 2018-03-18

TITLE
MagJack®
(4 Cores, MDIX, CM Termination)
08B0-1X1T-36-F

PART NO. / DRAWING NO.
08B01X1T36-F
FILE NAME
08B01X1T36-F_E.DWG

STANDARD DIM. TOL. IN INCH	[] METRIC DIM. AS REF.
.X	UNIT : INCH [mm]
.XX	SCALE : N/A
.XXX ±0.010	SIZE : A4

REV. : E	PAGE : 3

THE INFORMATION CONTAINED HEREIN IS CONSIDERED "PROPRIETARY" TO BEL FUSE INC. AND SHALL NOT BE COPIED, REPRODUCED OR DISCLOSED WITHOUT THE WRITTEN APPROVAL OF BEL FUSE INC.

RoHS

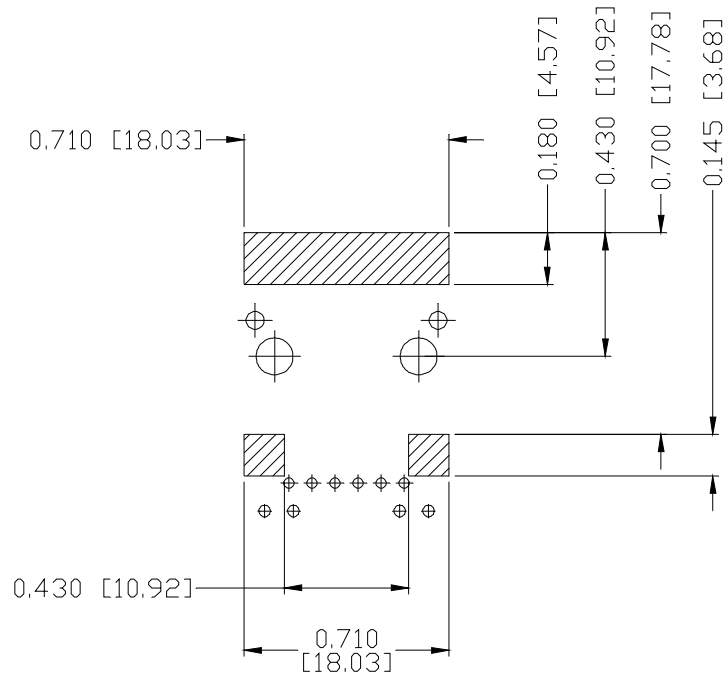

RECOMMENDED PCB FOOTPRINT
COMPONENT SIDE VIEW

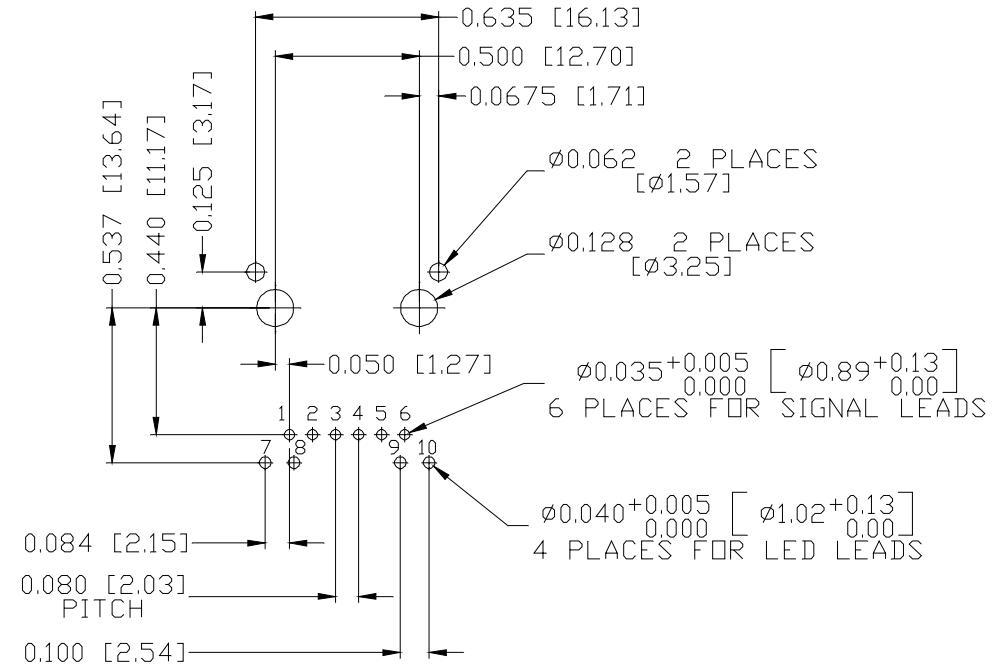

NOTES:

THE SHADED AREA ON THE CUSTOMER BOARD ARE RECOMMENDED TO BE CLEAR OFF ANY VIA HOLE OR COMPONENT PAD.

REV. : E PAGE : 4

ORIGINATED BY
ANTON LIAO
DATE 2018-03-18
DRAWN BY
JESSE LI
DATE 2018-03-18

TITLE
MagJack®
(4 Cores, MDIX, CM Termination)
08B0-1X1T-36-F

PART NO. / DRAWING NO.
08B01X1T36-F
FILE NAME
08B01X1T36-F_E.DWG

STANDARD DIM. TOL. IN INCH	[] METRIC DIM. AS REF.
.X	UNIT : INCH [mm]
.XX	SCALE : N/A
.XXX ±0.004	SIZE : A4



THE INFORMATION CONTAINED HEREIN IS CONSIDERED "PROPRIETARY" TO BEL FUSE INC. AND SHALL NOT BE COPIED, REPRODUCED OR DISCLOSED WITHOUT THE WRITTEN APPROVAL OF BEL FUSE INC.

RoHS



SUGGESTED PANEL OPENING

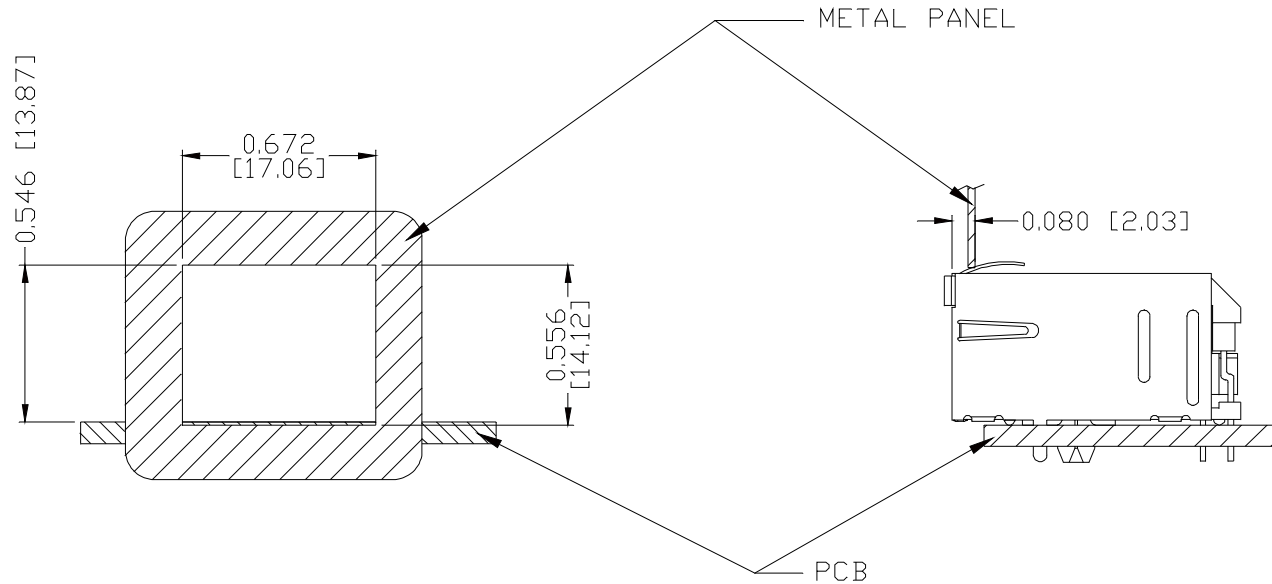

NOTE:

THE DISTANCE OF PANEL INSIDE SURFACE RELATIVE TO FRONT SURFACE OF PART IS ONLY A SUGGESTION. IN CASE THIS DISTANCE IS DIFFERENT, THE REQUIRED PANEL OPENING DIMENSIONS CHANGE ACCORDINGLY.

PACKING INFORMATION

PACKING TRAY : 0200-9999-D4(TOP)
0200-9999-D5(BOTTOM)

PACKING QUANTITY : 60 PCS FINISHED GOODS PER TRAY
11 TRAYS (660 PCS FINISHED GOODS) PER CARTON BOX

NOTE : CARDBOARDS ARE PLACED BETWEEN LAYERS OF PACKING TRAY INSIDE CARTON BOX
(INCLUDE THE UPPERMOST AND LOWERMOST TRAY)

REV. : E PAGE : 5

ORIGINATED BY ANTON LIAO DATE 2018-03-18	TITLE MagJack® (4 Cores, MDIX, CM Termination)	PART NO. / DRAWING NO. 08B01X1T36-F	STANDARD DIM. [] METRIC DIM.	
			TOL. IN INCH	AS REF.
			.X	UNIT : INCH [mm]
DRAWN BY JESSE LI DATE 2018-03-18	08B0-1X1T-36-F	FILE NAME 08B01X1T36-F_E.DWG	.XX	SCALE : N/A
			.XXX	±0.005
			SIZE : A4	

