

Features

- High speed
 - $t_{AA} = 10 \text{ ns}$
- Low active power
 - $I_{CC} = 110 \text{ mA}$ at $f = 100 \text{ MHz}$
- Low CMOS standby power
 - $I_{SB2} = 20 \text{ mA}$
- 2.0 V data retention
- Automatic power down when deselected
- TTL-compatible inputs and outputs
- Easy memory expansion with \overline{CE} and \overline{OE} features
- Available in Pb-free 44-pin TSOP-II package
- Offered in standard and high reliability (Q) grades

Functional Description

The CY7C1059DV33 is a high performance CMOS Static RAM organized as 1M words by 8 bits. Easy memory expansion is provided by an active LOW Chip Enable (\overline{CE}), an active LOW Output Enable (\overline{OE}), and tri-state drivers. To write to the device, take Chip Enable (\overline{CE}) and Write Enable (\overline{WE}) inputs LOW. Data on the eight I/O pins (I/O_0 through I/O_7) is then written into the location specified on the address pins (A_0 through A_{19}).

To read from the device, take Chip Enable (\overline{CE}) and Output Enable (\overline{OE}) LOW while forcing Write Enable (\overline{WE}) HIGH. Under these conditions, the contents of the memory location specified by the address pins appear on the I/O pins.

The eight input or output pins (I/O_0 through I/O_7) are placed in a high impedance state when the device is deselected (\overline{CE} HIGH), the outputs are disabled (\overline{OE} HIGH), or a write operation is in progress (\overline{CE} LOW and \overline{WE} LOW).

The CY7C1059DV33 is available in 44-pin TSOP-II package with center power and ground (revolutionary) pinout.

For a complete list of related documentation, click [here](#).

Logic Block Diagram

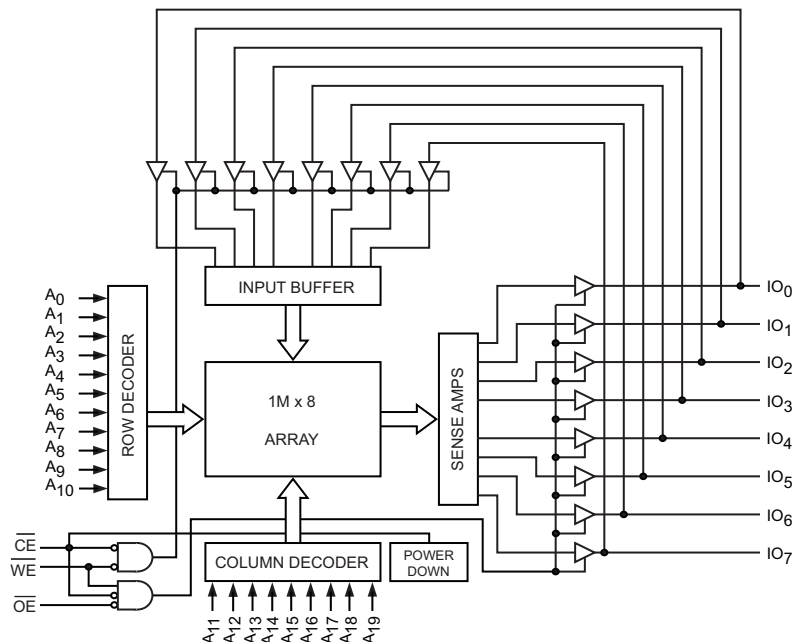

Pin Configuration

Figure 1. 44-Pin TSOP II

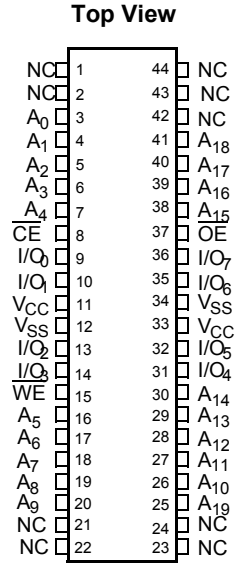

Selection Guide

Description	-10	-12	Unit
Maximum access time	10	12	ns
Maximum operating current	110	100	mA
Maximum CMOS standby current	20	20	mA

Maximum Ratings

Exceeding maximum ratings may shorten the useful life of the device. User guidelines are not tested.

Storage temperature -65 °C to +150 °C
 Ambient temperature with power applied -55 °C to +125 °C
 Supply voltage on V_{CC} to relative GND^[1] -0.5 V to + 4.6 V
 DC voltage applied to outputs in high-Z state^[1] -0.3 V to $V_{CC} + 0.3$ V

DC input voltage^[1] -0.3 V to $V_{CC} + 0.3$ V
 Current into outputs (LOW) 20 mA
 Static discharge voltage >2001 V (MIL-STD-883, Method 3015)
 Latch-up current >200 mA

Operating Range

Range	Ambient Temperature	V_{CC}
Industrial	-40 °C to +85 °C	3.3 V ± 0.3 V

Electrical Characteristics

Over the Operating Range

Parameter	Description	Test Conditions	-10		-12		Unit
			Min	Max	Min	Max	
V_{OH}	Output HIGH voltage	$V_{CC} = \text{Min}, I_{OH} = -4.0 \text{ mA}$	2.4	-	2.4	-	V
V_{OL}	Output LOW voltage	$V_{CC} = \text{Min}, I_{OL} = 8.0 \text{ mA}$	-	0.4	-	0.4	V
V_{IH}	Input HIGH voltage		2.0	$V_{CC} + 0.3$	2.0	$V_{CC} + 0.3$	V
V_{IL}	Input LOW voltage ^[1]		-0.3	0.8	-0.3	0.8	V
I_{IX}	Input leakage current	$GND \leq V_{IN} \leq V_{CC}$	-1	+1	-1	+1	µA
I_{OZ}	Output leakage current	$GND \leq V_{OUT} \leq V_{CC}$, output disabled	-1	+1	-1	+1	µA
I_{CC}	V_{CC} operating supply current	$V_{CC} = \text{Max.}, f = f_{MAX} = 1/t_{RC}$	-	110	-	100	mA
I_{SB1}	Automatic CE power-down current — TTL inputs	Max. $V_{CC}, \overline{CE} \geq V_{IH}, V_{IN} \geq V_{IH}$ or $V_{IN} \leq V_{IL}, f = f_{MAX}$	-	40	-	35	mA
I_{SB2}	Automatic CE power-down current — CMOS inputs	Max. $V_{CC}, \overline{CE} \geq V_{CC} - 0.3 \text{ V}, V_{IN} \geq V_{CC} - 0.3 \text{ V},$ or $V_{IN} \leq 0.3 \text{ V}, f = 0$	-	20	-	20	mA

Capacitance

Tested initially and after any design or process changes that may affect these parameters.

Parameter	Description	Test Conditions	Max	Unit
C_{IN}	Input capacitance	$T_A = 25 \text{ °C}, f = 1 \text{ MHz}, V_{CC} = 3.3 \text{ V}$	12	pF
C_{OUT}	I/O capacitance		12	pF

Thermal Resistance

Tested initially and after any design or process changes that may affect these parameters.

Parameter	Description	Test Conditions	TSOP II	Unit
θ_{JA}	Thermal resistance (Junction to ambient)	Still air, soldered on a 3 × 4.5 inch, four-layer printed circuit board	51.43	°C/W
θ_{JC}	Thermal resistance (Junction to case)		15.8	°C/W

Notes

- $V_{IL(\text{min})} = -2.0 \text{ V}$ and $V_{IH(\text{max})} = V_{CC} + 2 \text{ V}$ for pulse durations of less than 20 ns.
- Tested initially and after any design or process changes that may affect these parameters.

AC Test Loads and Waveforms

AC characteristics (except High-Z) are tested using the load conditions shown in Figure 2 (a). High-Z characteristics are tested for all speeds using the test load shown in Figure 2 (c).

Figure 2. AC Test Loads and Waveforms

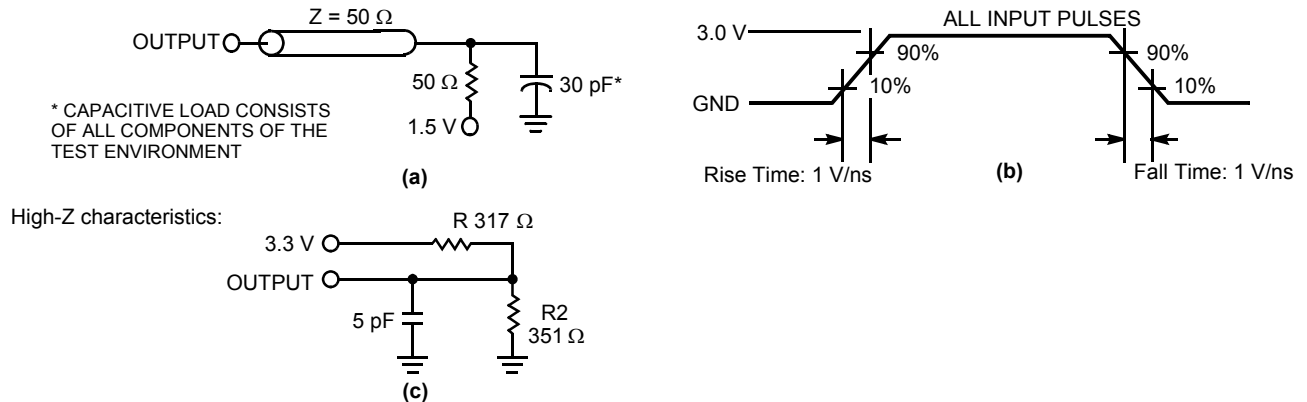

Data Retention Characteristics

Over the Operating Range

Parameter	Description	Conditions ^[3]	Min	Max	Unit
V_{DR}	V_{CC} for data retention		2.0	–	V
I_{CCDR}	Data retention current	$V_{CC} = V_{DR} = 2.0\text{ V}$, $\overline{CE} \geq V_{CC} - 0.3\text{ V}$, $V_{IN} \geq V_{CC} - 0.3\text{ V}$ or $V_{IN} \leq 0.3\text{ V}$	–	20	mA
$t_{CDR}^{[2]}$	Chip deselect to data retention time		0	–	ns
$t_R^{[4]}$	Operation recovery time		t_{RC}	–	ns

Figure 3. Data Retention Waveform

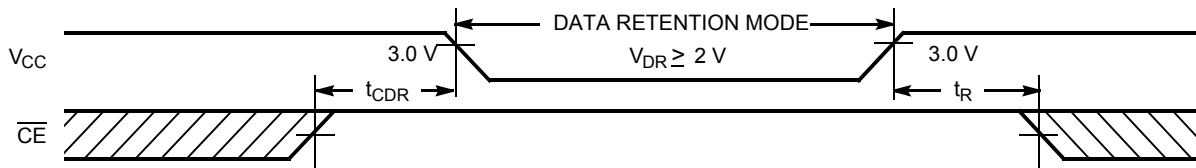

Notes

- 3. No inputs may exceed $V_{CC} + 0.3\text{ V}$.
- 4. Full device operation requires linear V_{CC} ramp from V_{DR} to $V_{CC(min)} \geq 50\ \mu\text{s}$ or stable at $V_{CC(min)} \geq 50\ \mu\text{s}$.

AC Switching Characteristics

Over the Operating Range^[5]

Parameter	Description	-10		-12		Unit
		Min	Max	Min	Max	
Read Cycle						
$t_{\text{power}}^{[6]}$	V_{CC} (typical) to the first access	100	–	100	–	μs
t_{RC}	Read cycle time	10	–	12	–	ns
t_{AA}	Address to data valid	–	10	–	12	ns
t_{OHA}	Data hold from address change	2.5	–	2.5	–	ns
t_{ACE}	$\overline{\text{CE}}$ LOW to data valid	–	10	–	12	ns
t_{DOE}	$\overline{\text{OE}}$ LOW to data valid	–	5	–	6	ns
t_{LZOE}	$\overline{\text{OE}}$ LOW to low-Z	0	–	0	–	ns
t_{HZOE}	$\overline{\text{OE}}$ HIGH to high-Z ^[7, 8]	–	5	–	6	ns
t_{LZCE}	$\overline{\text{CE}}$ LOW to low-Z ^[8]	3	–	3	–	ns
t_{HZCE}	$\overline{\text{CE}}$ HIGH to high-Z ^[7, 8]	–	5	–	6	ns
t_{PU}	$\overline{\text{CE}}$ LOW to power-up	0	–	0	–	ns
t_{PD}	$\overline{\text{CE}}$ HIGH to power-down	–	10	–	12	ns
Write Cycle^[9, 10]						
t_{WC}	Write cycle time	10	–	12	–	ns
t_{SCE}	$\overline{\text{CE}}$ LOW to write end	7	–	8	–	ns
t_{AW}	Address setup to write end	7	–	8	–	ns
t_{HA}	Address hold from write end	0	–	0	–	ns
t_{SA}	Address setup to write start	0	–	0	–	ns
t_{PWE}	$\overline{\text{WE}}$ pulse width	7	–	8	–	ns
t_{SD}	Data setup to write end	5	–	6	–	ns
t_{HD}	Data hold from write end	0	–	0	–	ns
t_{LZWE}	$\overline{\text{WE}}$ HIGH to low-Z ^[8]	3	–	3	–	ns
t_{HZWE}	$\overline{\text{WE}}$ LOW to high-Z ^[7, 8]	–	5	–	6	ns

Notes

5. Test conditions assume signal transition time of 3 ns or less, timing reference levels of 1.5 V, input pulse levels of 0 to 3.0 V.
6. t_{POWER} is the minimum amount of time that the power supply must be at stable, typical V_{CC} values until the first memory access can be performed.
7. t_{HZOE} , t_{HZCE} , and t_{HZWE} are specified with a load capacitance of 5 pF as in part (d) of "AC Test Loads and Waveforms" on page 4. Transition is measured when the outputs enter a high impedance state.
8. At any temperature and voltage condition, t_{HZCE} is less than t_{LZCE} , t_{HZOE} is less than t_{LZOE} , and t_{HZWE} is less than t_{LZWE} for any device.
9. The internal write time of the memory is defined by the overlap of $\overline{\text{CE}}$ LOW, and $\overline{\text{WE}}$ LOW. $\overline{\text{CE}}$ and $\overline{\text{WE}}$ must be LOW to initiate a write, and the transition of either of these signals can terminate the write. The input data setup and hold timing must refer to the leading edge of the signal that terminates the Write.
10. The minimum write cycle time for Write Cycle No. 2 ($\overline{\text{WE}}$ controlled, $\overline{\text{OE}}$ LOW) is the sum of t_{HZWE} and t_{SD} .

Switching Waveforms

Figure 4. Read Cycle No. 1 (Address Transition Controlled)^[11, 12]

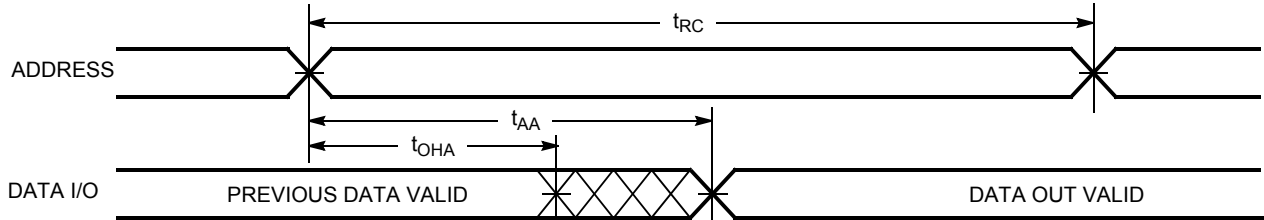
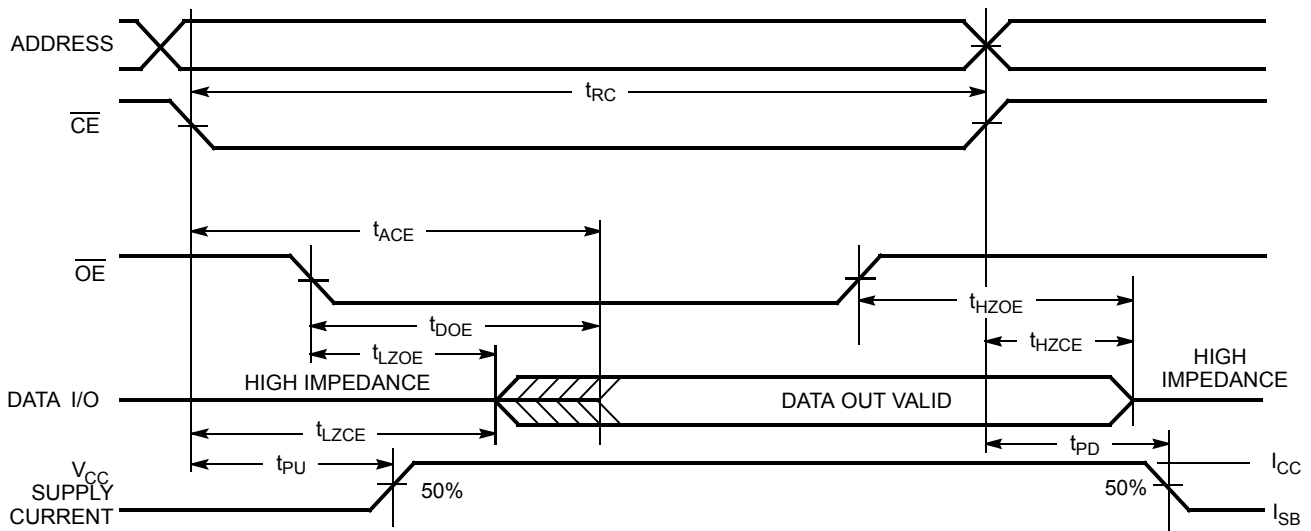

Figure 5. Read Cycle No. 2 (\overline{OE} Controlled)^[12, 13]



Notes

- 11. Device is continuously selected. \overline{OE} , $\overline{CE} = V_{IL}$.
- 12. \overline{WE} is HIGH for Read cycle.
- 13. Address valid before or coincident with \overline{CE} transition LOW.

Switching Waveforms(continued)

Figure 6. Write Cycle No. 1 (\overline{WE} Controlled, \overline{OE} High During Write)^[14, 15]

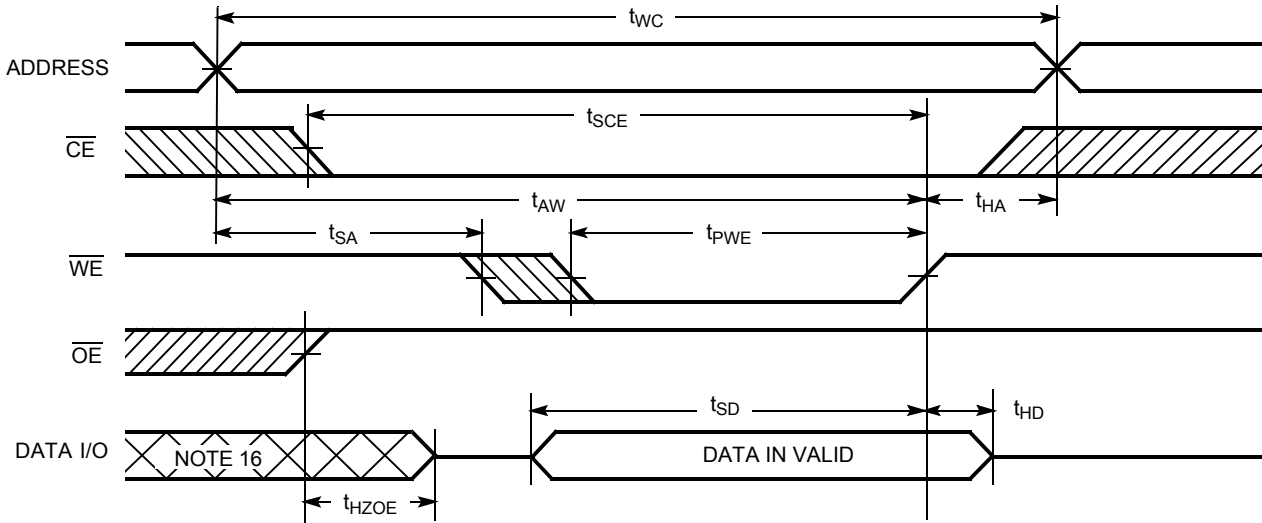
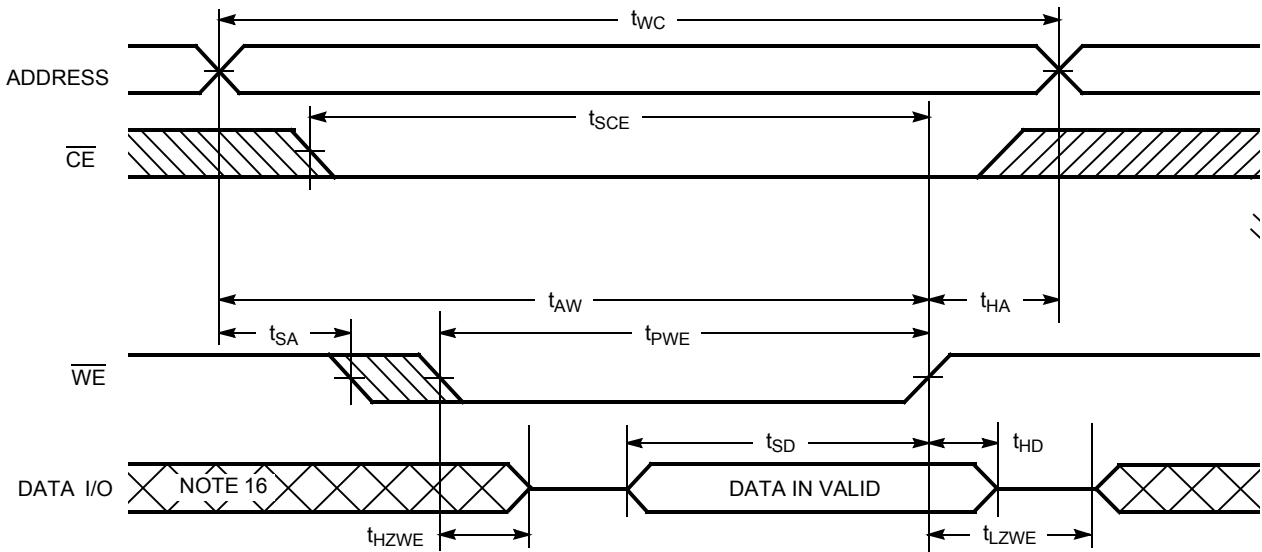

Figure 7. Write Cycle No. 2 (\overline{WE} Controlled, \overline{OE} Low)^[15, 17]



Notes

- 14. Data I/O is high-impedance if $\overline{OE} = V_{IH}$.
- 15. If \overline{CE} goes HIGH simultaneously with \overline{WE} going HIGH, the output remains in a high-impedance state.
- 16. During this period the I/Os are in the output state and input signals must not be applied.
- 17. The minimum write cycle time for Write Cycle No. 2 (\overline{WE} controlled, \overline{OE} LOW) is the sum of t_{HZWE} and t_{SD} .

Truth Table

\overline{CE}	\overline{OE}	\overline{WE}	I/O ₀ -I/O ₇	Mode	Power
H	X	X	High-Z	Power-down	Standby (I _{SB})
L	L	H	Data out	Read	Active (I _{CC})
L	X	L	Data in	Write	Active (I _{CC})
L	H	H	High-Z	Selected, outputs disabled	Active (I _{CC})

Ordering Information

Speed (ns)	Ordering Code	Package Diagram	Package Type	Operating Range	Grade
10	CY7C1059DV33-10ZSXI	51-85087	44-pin TSOP II (Pb-free)	Industrial	Standard
12	CY7C1059DV33-12ZSXQ	51-85087	44-pin TSOP II (Pb-free)	Industrial	High reliability (< 100 ppm)

Ordering Code Definitions

CY 7 C 1 05 9 D V33 - XX ZSX X

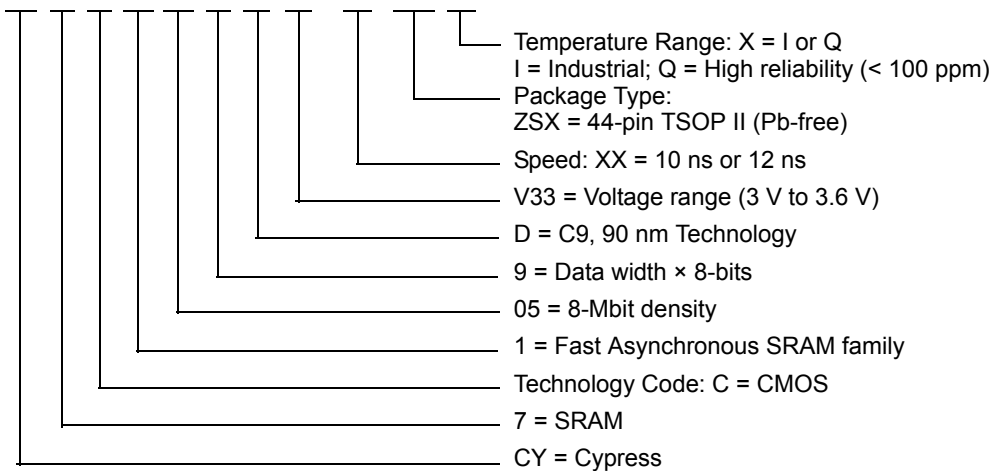

Contact your local Cypress sales representative for availability of these parts.

Package Diagram

Figure 8. 44-Pin TSOP II (51-85087)

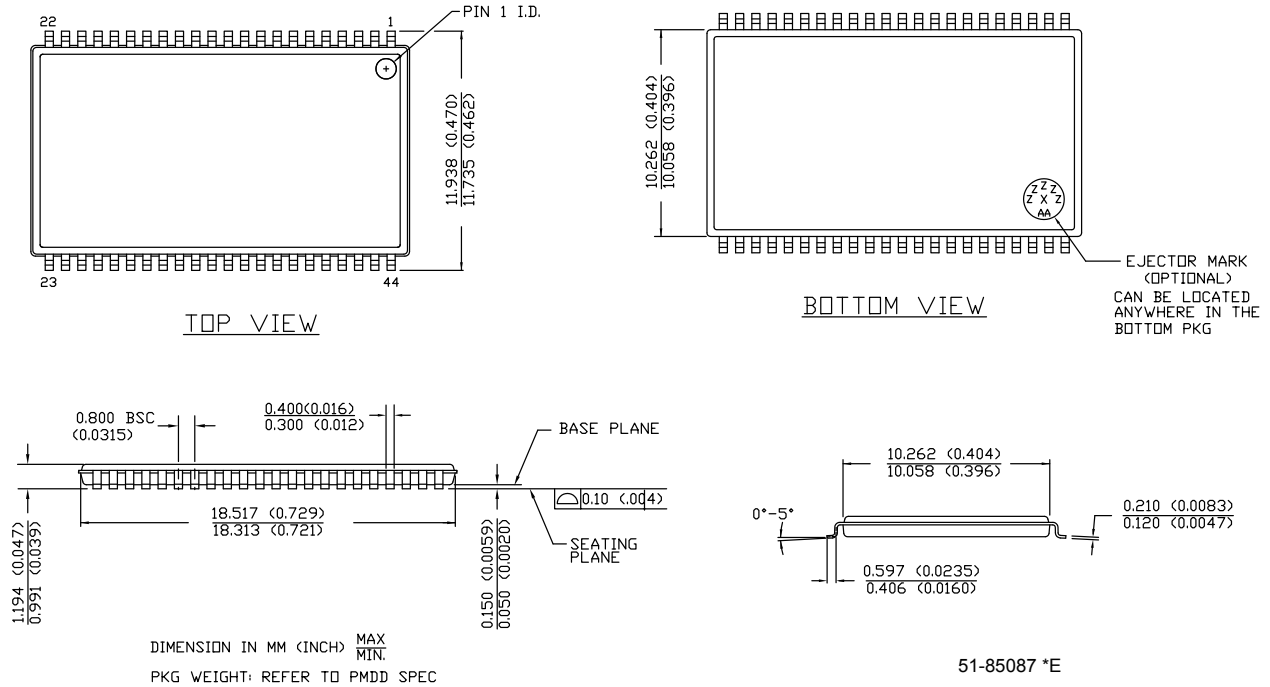

Acronyms

Table 1. Acronyms Used in this Document

Acronym	Description
CMOS	complementary metal-oxide-semiconductor
SRAM	static random-access memory
TSOP	thin small-outline package
TTL	transistor-transistor logic

Document Conventions

Units of Measure

Table 2. Units of Measure

Symbol	Unit of Measure
°C	degree Celsius
MHz	megahertz
mA	milliampere
ns	nanosecond
Ω	ohm
pF	picofarad

Document History Page

Document Title: CY7C1059DV33, 8-Mbit (1M × 8) Static RAM				
Document Number: 001-00061				
Revision	ECN	Orig. of Change	Submission Date	Description of Change
**	342195	PCI	See ECN	New data sheet
*A	380574	SYT	See ECN	Redefined I _{CC} values for Com'I and Ind'I temperature ranges I _{CC} (Com'I): Changed from 110, 90 and 80 mA to 110, 100 and 95 mA for 8, 10 and 12 ns speed bins respectively I _{CC} (Ind'I): Changed from 110, 90 and 80 mA to 120, 110 and 105 mA for 8, 10 and 12 ns speed bins respectively Changed the Capacitance values from 8 pF to 10 pF on Page # 3
*B	485796	NXR	See ECN	Changed address of Cypress Semiconductor Corporation on Page# 1 from "3901 North First Street" to "198 Champion Court" Removed -8 and -12 Speed bins from product offering, Removed Commercial Operating Range option, Modified Maximum Ratings for DC input voltage from -0.5 V to -0.3 V and V _{CC} + 0.5 V to V _{CC} + 0.3 V Updated footnote #7 on High-Z parameter measurement Added footnote #11 Changed the Description of I _{IX} from Input Load Current to Input Leakage Current. Updated the Ordering Information table and Replaced Package Name column with Package Diagram.
*C	1513285	VKN/AESA	See ECN	Converted from preliminary to final Added 12 ns speed bin Changed C _{IN} and C _{OUT} specs from 16 pF to 12 pF Changed t _{OHA} spec from 3 ns to 2.5 ns Updated Ordering information table
*D	2594352	NXR/PYRS	10/21/08	Added Q-Grade part
*E	2764423	AJU	09/16/2009	Corrected typo in the ordering information table
*F	2902563	AJU	03/31/2010	Removed inactive part from Ordering Information table. Updated package diagram.
*G	3109147	AJU	12/13/2010	Added Ordering Code Definitions .
*H	3369075	TAVA	09/12/2011	Changed Features section: "I _{CC} = 110 mA at 10 ns" to "110 mA at f = 100 MHz". Removed reference to "AN1064, SRAM System Guidelines" on page 1. Removed reference to 36-ball FBGA from Functional Description section. Updated figures under Switching Waveforms section. Updated package diagram revision to *D. Added acronyms and units of measure.
*I	4530384	MEMJ	10/09/2014	Updated Switching Waveforms : Added Note 17 and referred the same note in Figure 7 . Updated Package Diagram : spec 51-85087 – Changed revision from *D to *E. Updated in new template. Completing Sunset Review.
*J	4578447	MEMJ	01/16/2015	Added related documentation hyperlink in page 1.

Sales, Solutions, and Legal Information

Worldwide Sales and Design Support

Cypress maintains a worldwide network of offices, solution centers, manufacturer's representatives, and distributors. To find the office closest to you, visit us at [Cypress Locations](#).

Products

Automotive	cypress.com/go/automotive
Clocks & Buffers	cypress.com/go/clocks
Interface	cypress.com/go/interface
Lighting & Power Control	cypress.com/go/powerpsoc
Memory	cypress.com/go/memory
PSoC	cypress.com/go/psoc
Touch Sensing	cypress.com/go/touch
USB Controllers	cypress.com/go/USB
Wireless/RF	cypress.com/go/wireless

PSoC[®] Solutions

psoc.cypress.com/solutions
PSoC 1 | PSoC 3 | PSoC 4 | PSoC 5LP

Cypress Developer Community

[Community](#) | [Forums](#) | [Blogs](#) | [Video](#) | [Training](#)

Technical Support

cypress.com/go/support

© Cypress Semiconductor Corporation, 2005-2015. The information contained herein is subject to change without notice. Cypress Semiconductor Corporation assumes no responsibility for the use of any circuitry other than circuitry embodied in a Cypress product. Nor does it convey or imply any license under patent or other rights. Cypress products are not warranted nor intended to be used for medical, life support, life saving, critical control or safety applications, unless pursuant to an express written agreement with Cypress. Furthermore, Cypress does not authorize its products for use as critical components in life-support systems where a malfunction or failure may reasonably be expected to result in significant injury to the user. The inclusion of Cypress products in life-support systems application implies that the manufacturer assumes all risk of such use and in doing so indemnifies Cypress against all charges.

Any Source Code (software and/or firmware) is owned by Cypress Semiconductor Corporation (Cypress) and is protected by and subject to worldwide patent protection (United States and foreign), United States copyright laws and international treaty provisions. Cypress hereby grants to licensee a personal, non-exclusive, non-transferable license to copy, use, modify, create derivative works of, and compile the Cypress Source Code and derivative works for the sole purpose of creating custom software and or firmware in support of licensee product to be used only in conjunction with a Cypress integrated circuit as specified in the applicable agreement. Any reproduction, modification, translation, compilation, or representation of this Source Code except as specified above is prohibited without the express written permission of Cypress.

Disclaimer: CYPRESS MAKES NO WARRANTY OF ANY KIND, EXPRESS OR IMPLIED, WITH REGARD TO THIS MATERIAL, INCLUDING, BUT NOT LIMITED TO, THE IMPLIED WARRANTIES OF MERCHANTABILITY AND FITNESS FOR A PARTICULAR PURPOSE. Cypress reserves the right to make changes without further notice to the materials described herein. Cypress does not assume any liability arising out of the application or use of any product or circuit described herein. Cypress does not authorize its products for use as critical components in life-support systems where a malfunction or failure may reasonably be expected to result in significant injury to the user. The inclusion of Cypress' product in a life-support systems application implies that the manufacturer assumes all risk of such use and in doing so indemnifies Cypress against all charges.

Use may be limited by and subject to the applicable Cypress software license agreement.