

RECOMMENDED PCB LAYOUT (CONNECTOR SIDE)
THICKNESS=1.20mm, GENERAL TOLERANCE: ±0.05

NOTES:

- MATERIAL:
HOUSING/COVER: LCP. COLOR: BLACK.
SHELL: BRASS.
TERMINAL: BRASS.
- PLATING:
TERMINAL: CONTACT AREA: 0.127 MICROMETRE GOLD FLASH.
SOLDER AREA: 3 MICROMETRE MIN. TIN-BISMUTH ALLOY PLATED.
UNDER PLATE: 1.27 MICROMETRE MIN. NICKEL.
SHELL: 3 MICROMETRE MIN. MATTE TIN PLATING OVER
1.27 MICROMETRE NICKEL PLATING OVERALL.
- COPLANARITY: 0.10mm MAX (BEFORE AND AFTER REFLOW).
- DATE CODE: "YYMMDDA", "YY" REPRESENTS YEAR; "MM" REPRESENTS MONTH; "DD" REPRESENTS DAY; "A" REPRESENTS SHIFT.
- PRODUCT SPECIFICATION REFER TO PS-105153-001.
- PACKAGE SPECIFICATION REFER TO TABLE.
- PRODUCT COMPLIANT TO RoHS DIRECTIVE 2002/95/EC AND ELV DIRECTIVE 2000/53/EC.

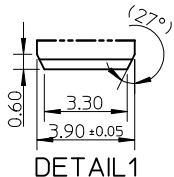
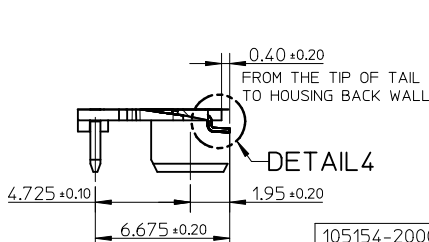
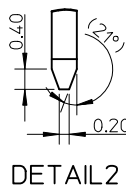
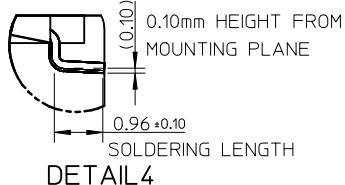
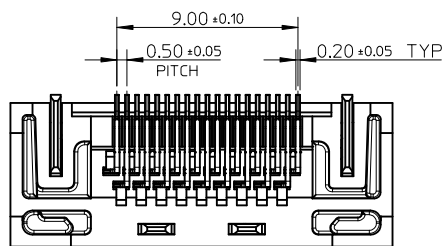
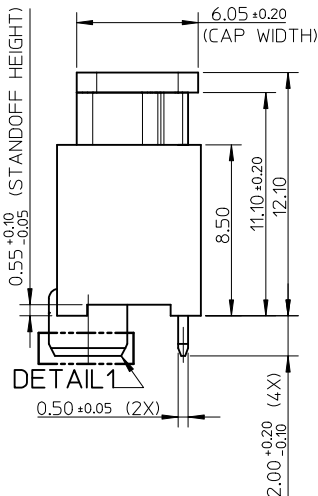
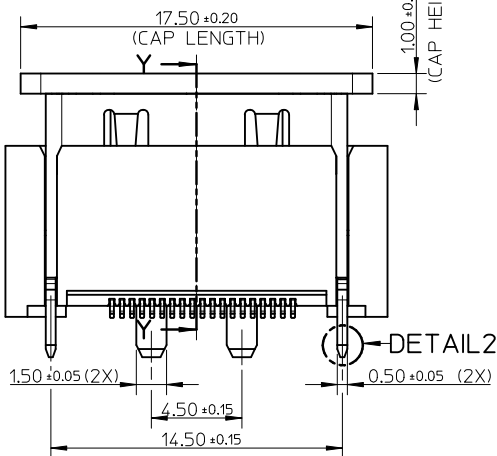

105154-2000	PK-105154-001 (TRAY)
105154-1000	PK-105154-999 (T&R)
PART NUMBER	PACKING SPEC

NEW RELEASE EC NO: S2012-0855 DRWN: JESSIECHUA 2012/06/06 CHKD: CWANG25 2011/08/22 APPR: SHONG 2012/06/27	QUALITY SYMBOLS	GENERAL TOLERANCES (UNLESS SPECIFIED)	DIMENSION STYLE	SCALE	DESIGN UNITS	THIRD ANGLE PROJECTION
	▽ _F =0	mm INCH	MM ONLY	NTS	METRIC	⊙ □
	▽ _E =0	4 PLACES ± --- ± ---	DRAWN BY DATE	TITLE	HDMI RECEPTACLE VERTICAL SMT TYPE WITHOUT FLANGE	
	▽ _D =0	3 PLACES ± --- ± ---	CHECKED BY DATE	JESSIECHUA 2012/06/06	MOLEX INCORPORATED	

4 PLACES ± --- ± ---	2 PLACES ± 0.20 ± ---	1 PLACE ± 0.30 ± ---	ANGULAR ± 2 °	DRAFT WHERE APPLICABLE MUST REMAIN WITHIN DIMENSIONS
APPROVED BY DATE		MATERIAL NO.		SEE TABLE
SHONG 2012/06/27		SD-105154-200		THIS DRAWING CONTAINS INFORMATION THAT IS PROPRIETARY TO MOLEX INCORPORATED AND SHOULD NOT BE USED WITHOUT WRITTEN PERMISSION

3 PLACES ± --- ± ---	2 PLACES ± 0.20 ± ---	1 PLACE ± 0.30 ± ---	ANGULAR ± 2 °	DRAFT WHERE APPLICABLE MUST REMAIN WITHIN DIMENSIONS
APPROVED BY DATE		MATERIAL NO.		SEE TABLE
SHONG 2012/06/27		SD-105154-200		THIS DRAWING CONTAINS INFORMATION THAT IS PROPRIETARY TO MOLEX INCORPORATED AND SHOULD NOT BE USED WITHOUT WRITTEN PERMISSION

3 PLACES ± --- ± ---	2 PLACES ± 0.20 ± ---	1 PLACE ± 0.30 ± ---	ANGULAR ± 2 °	DRAFT WHERE APPLICABLE MUST REMAIN WITHIN DIMENSIONS
APPROVED BY DATE		MATERIAL NO.		SEE TABLE
SHONG 2012/06/27		SD-105154-200		THIS DRAWING CONTAINS INFORMATION THAT IS PROPRIETARY TO MOLEX INCORPORATED AND SHOULD NOT BE USED WITHOUT WRITTEN PERMISSION