

# enGage II: Pressure Monitor

## 3011R-27X-0001



### Technical Specifications

**Operating Voltage Range** 12V nominal voltage, +/- 25%

**Operating Current Range** Nominal- 19 mA, maximum 35 mA. Values reflect key switch in "on" position

**Display:** LCD with 10-segment bar and 5 digit numeric (5mm high)

**Hour Meter Range & Resolution:** 99,999 Total Hours

**Pressure Sender:** 10 ohms-0 psi; 134 ohms- 100 psi

**Hardware:** Mounting Bracket

**Panel Cutout:** 52 mm / 2 1/16" diameter

**Shock** SAE J 1378 Amplitude  
44-55 g, half sine, 9-13 ms duration

**Vibration** SAE J 1378 Double amplitude of 1.53mm with frequency sweep for 10-80-10 Hz (20 g max) at 1 minute intervals

**Storage Temperature:** -50°C to +90°C

**Operating Temperature:** -40°C to +85°C

**Humidity:** 95% RH (non-condensing)

**IP Rating:** 65 Front & Rear with AMP connector installed

### Terminal Assignments

Description	Connector Pin #
<i>(V+) Supply voltage positive terminal</i>	4
<i>(V-) Supply voltage negative terminal</i>	8
<i>Key switch (+):</i> When V+ is applied this switch operates the gauge display	6
<i>MOSFET output:</i> MOSFET (0.5A) open drain type internally tied to V-.	7
<i>Input:</i> Input for resistance based pressure sender.	5
<i>Hour Meter Enable (+):</i> When V+ applied, accumulation of time occurs when key switch on.	3

## Maintenance

The enGage™II 3000 Series is not serviceable.

## Safety Instructions

- This instrument was manufactured and tested according to the applicable technical standards. It complies with all the safety regulations as shipped from the factory.
- Installation and startup must be performed by skilled personnel.
- Failure to install and operate the unit in accordance with these instructions may result in damage or injury.
- If safe operation of the instrument can no longer be ensured, stop and secure it against accidental operation.
- If instrument failure or malfunction may cause personal injury or material damage, use additional safety measures such as limit switches, guards, etc.
- Read the Operating Instructions carefully before startup.
- Note the safety instructions marked with this warning symbol in this manual.

## Guarantee

Curtis Instruments' products and/or components are guaranteed against defects in workmanship and material for a period of two years, or as defined in the individual product literature, from date of shipment from our factory, when applied in a proper application within specified ratings. This guarantee is limited to repair or replacement F.O.B. our factory. There is no further warranty or implied representation, guarantee, promise or agreement as to any Curtis Instruments product and/or component. Curtis Instruments, Inc., cannot assume responsibility or accept invoices for unauthorized repairs to its products and/or components, even though defective. In no case will Curtis Instruments' responsibility extend to products, components or equipment not of its manufacture. Under no circumstances shall Curtis Instruments, Inc. be liable for any special or consequential damages or loss of profits or other damages. Returned goods will not be accepted unless identified by a Curtis Return Material Authorization (RMA). All specifications are subject to change without notice.

## Sender Troubleshoot

### Pressure Monitor Function

Problem	Possible Cause
No Display	Terminals not connected. Improper voltage.
Stays At High	Instrument voltage does not match battery voltage. V+ connected to wrong terminal.
Stays at Low	Instrument voltage does not match battery voltage. V+ connected to wrong terminal.

## Notes

1. Mating connector; 8-pin AMP, P/N 794821-1 with UL rating 94V-0. Interface seal, P/N 794772-0. Wire seal 794758-1, Pins P/N770904-X for #18-24 AWG.
2. Material: Case-polycarbonate, lens-clear polymethylmethacrylat (PMMA) cover, overlay and mounting bracket-polycarbonate.
3. This unit is designed for a mounting panel thickness of 0.8mm-6.4mm.
4. Panel cutout: 52mm diameter dash panel hole.

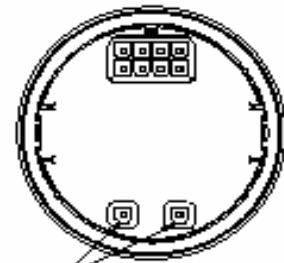

USED FOR DEVICE CONFIGURATION  
DO NOT CONNECT WHEN INSTALLING GAGE

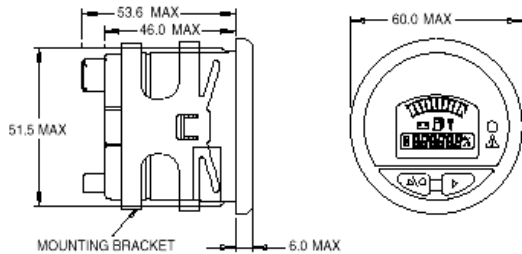

CAUTION!  
BRACKET IS PLACED OVER GAUGE IN REVERSE FASHION FOR EASE OF SHIPPING. BRACKET HAS BEEN DESIGNED TO REMAIN SECURED TO THE GAUGE UPON PROPER INSTALLATION. ONCE INSTALLED CORRECTLY, ATTEMPTS TO REMOVE BRACKET FROM GAUGE MAY RESULT IN DAMAGE TO THE BRACKET.

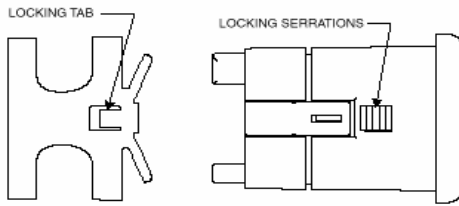

LOCKING TAB MUST ALIGN WITH LOCKING SERRATIONS

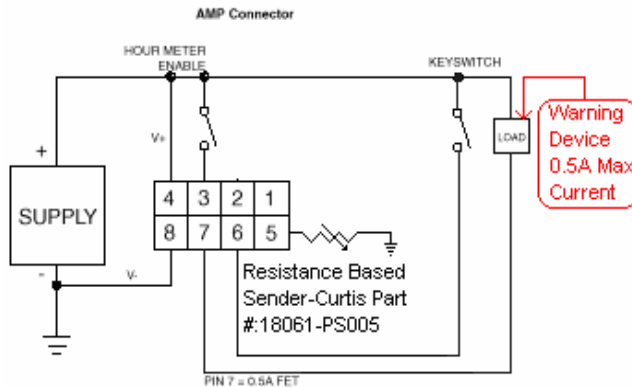

## Installation Procedure

1. Mount unit in standard SAE round cutout.
2. Connect supply voltage to pins indicated: (V+) pin 4, (V-) pin 8.
3. Connect pin 6, as appropriate for key switch, to enable gauge display.
4. Connect pin 5 as appropriate to input resistance based senders.
5. Connect pin 3 as appropriate to activate the hour meter.
6. Connect pin 7 to an audio, visual, horn, or other warning device (load). **Caution: Max current draw on warning device is 0.5 Amps.**

## Installation

### Caution!

Bracket has been designed to remain secured to the gauge upon proper installation. Once installed correctly, attempts to remove bracket from gauge may result in damage to the bracket.

Curtis enGage™ II instruments are mounted in a 52mm round cutout. Serrations on the barrel of the gauge, combined with the mounting bracket provided, insure fast and trouble free installation. To insure proper installation, the 2 locking tabs on either side of the inner diameter of the bracket should align with the serrations on the barrel of the gauge (see drawing above). Next, slide the bracket over the barrel of the gauge and press it firmly against back of panel. You should hear the tab sliding over the serrations.

Curtis enGage™ II mates with an 8-pin AMP connector (AMP pins P/N 770904-X FOR #18-24 AWG P/N 794821-1). A preassembled mating connector kit (Curtis P/N 17633308-03=AMP) with crimp-connect terminated wires (approx. 127mm in length) is also available.

## Output and Warning LED

Function	LED Activated	FET Opens
Pressure	LMB & RMB	LMB & RMB

### KEY

1. **RMB** = Right Most LCD Bar
2. **LMB** = Left Most LCD Bar.