

THIS DRAWING IS UNPUBLISHED.		RELEASED FOR PUBLICATION	
COPYRIGHT BY TYCO ELECTRONICS CORPORATION. ALL RIGHTS RESERVED.			
COMPONENT	MATERIAL	FINISH	
SHELL	STAINLESS STEEL PER ASTM-A-582 TYPE 303	PASSIVATED PER QQ-P-35	
DIELECTRIC	PTFE FLUORCARBON PER ASTM-D-1710	-	
CENTER CONTACT	BERYLLIUM COPPER PER ASTM-B-196	GOLD PLATED PER ASTM-B-488 OVER NICKEL PER QQ-N-290	
OUTER CONTACT	BERYLLIUM COPPER PER ASTM-B-196	GOLD PLATED PER ASTM-B-488 OVER NICKEL PER QQ-N-290	
RETAINER PLATE	ALUMINUM ALLOY PER ASTM-B-211 OR ASTM-B-209	ELECTROLESS NICKEL PER MIL-C-26074	
SCREW LOCKWASHER	STAINLESS STEEL PER ASTM-A-582 TYPE 303	PASSIVATED	

- 1 FLARE TO MEET OUTER CONTACT GAGE TEST PER MIL-C-39012/15
- 2 1757180-2 INCLUDES A RETAINER PLATE AND 4 SCREWS & LOCKWASHERS IN A SEPARATE CONTAINER.

LOC		DIST		REVISIONS			
DF	A0	P	LTR	DESCRIPTION	DATE	DWN	APVD
		A		REV PER ECO-07-029503	20DEC07	PY	KT

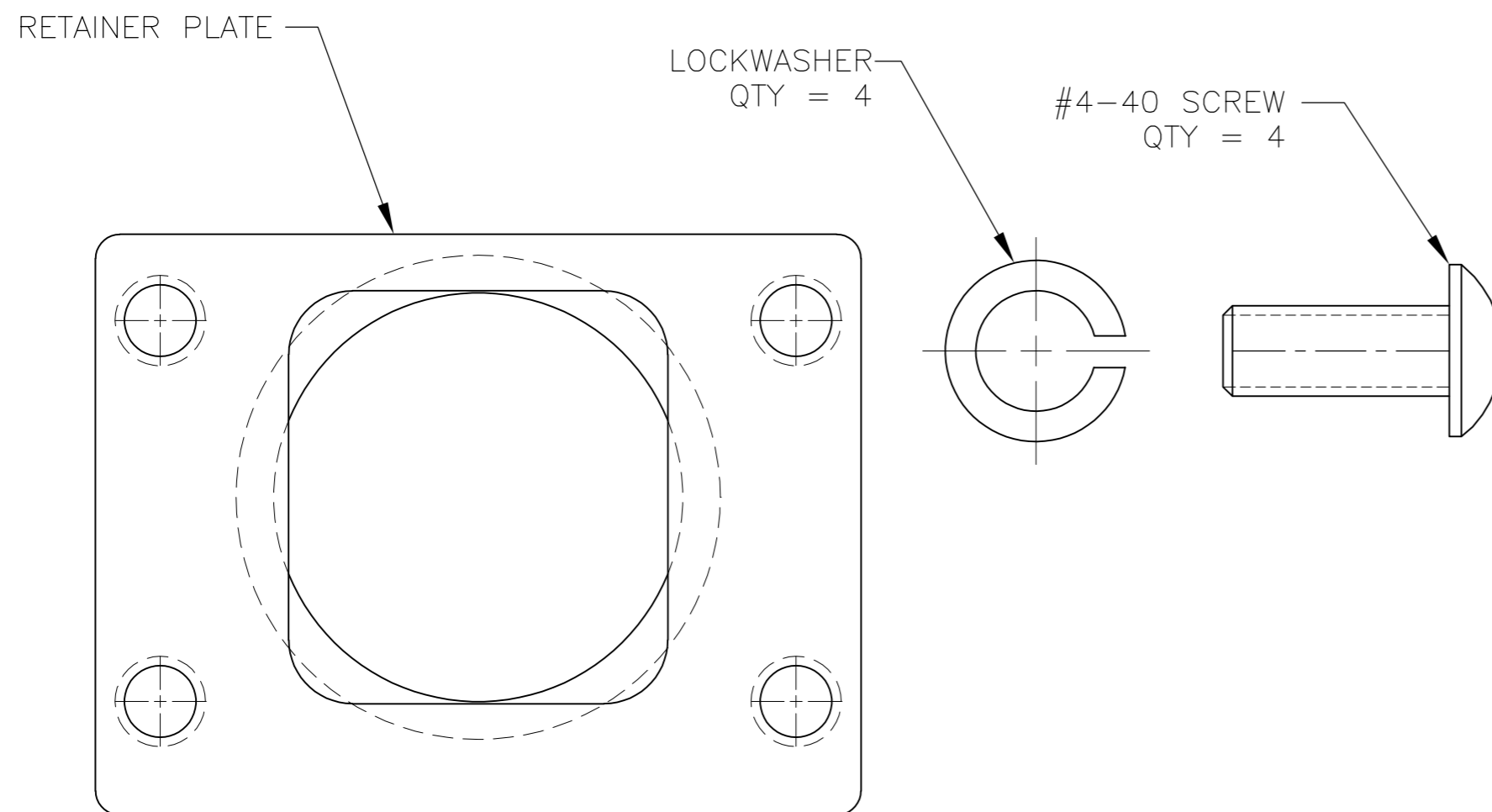
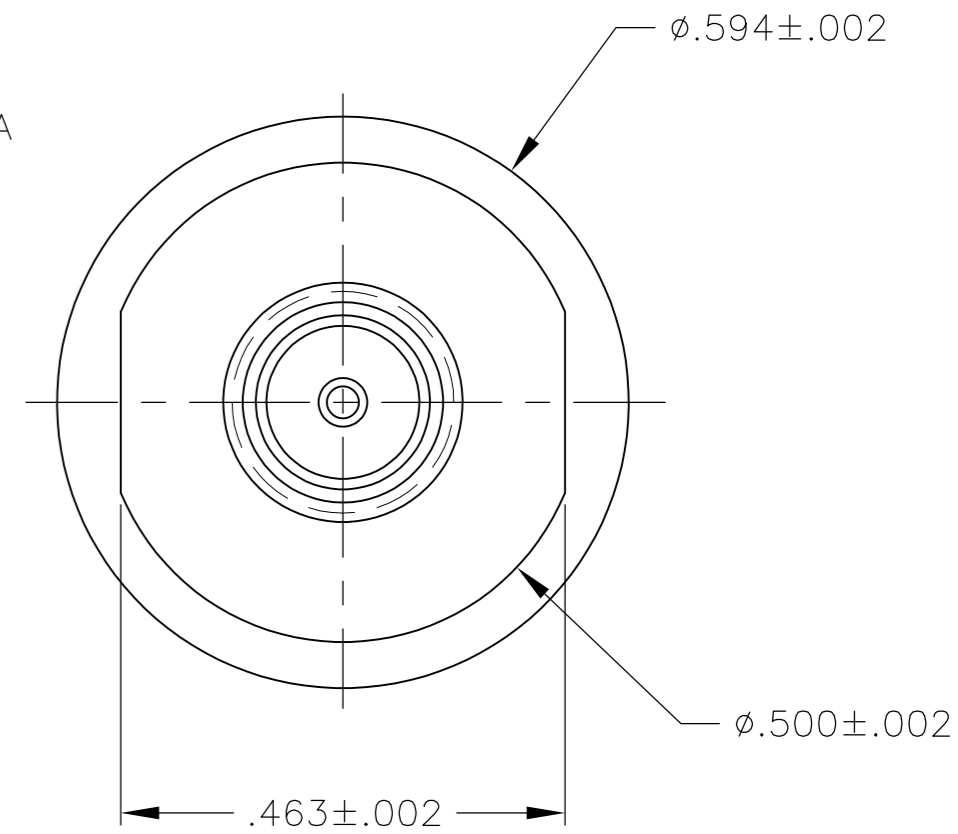
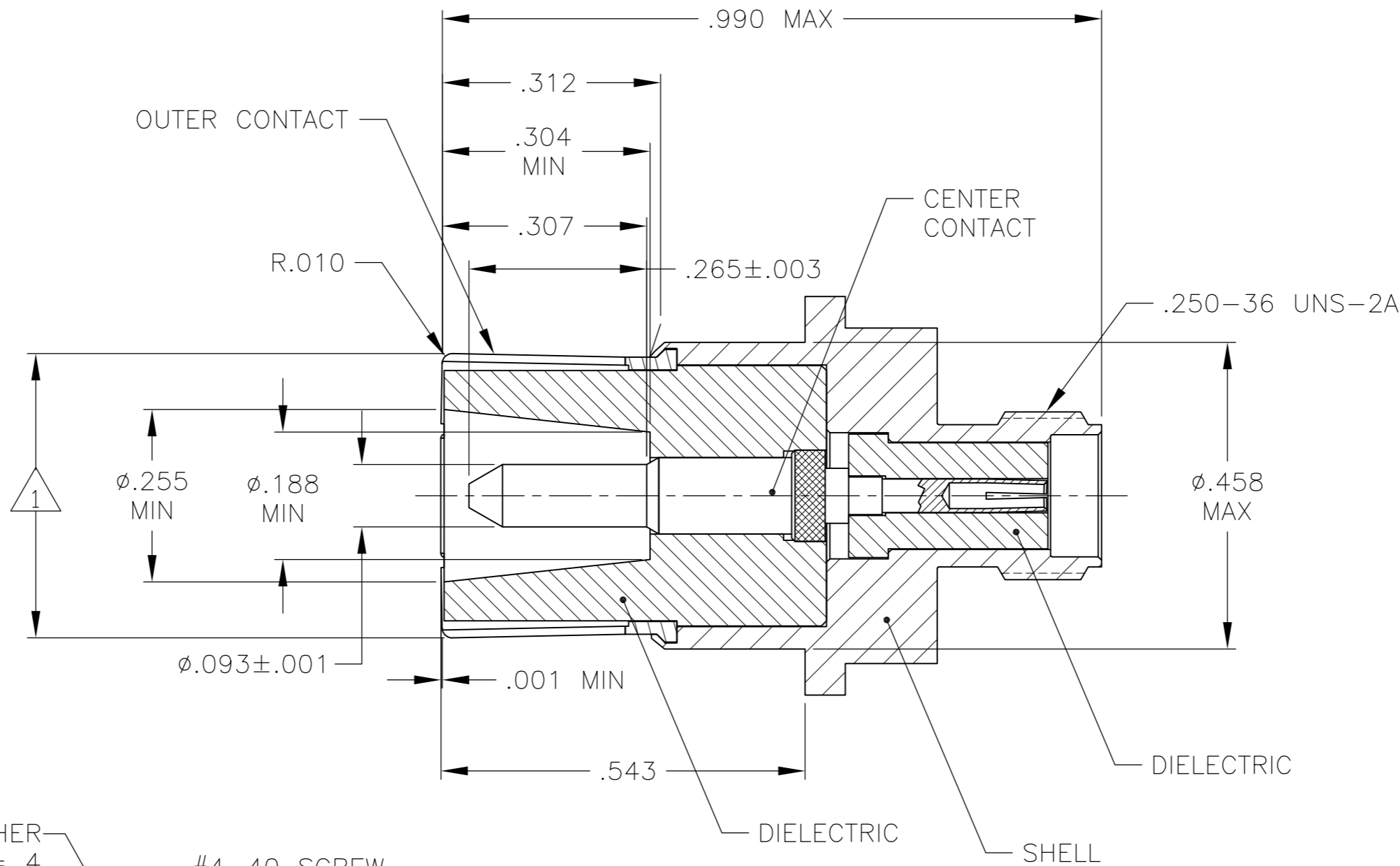

2	1757180-2
-	1757180-1
REMARKS	PART NO.

THIS DRAWING IS A CONTROLLED DOCUMENT.		DWN	C.C.THOMAS	9-2-04	Tyco Electronics Corporation Harrisburg, Pa 17105-3608		
DIMENSIONS: INCHES		CHK	S.GLATFELTER	9-2-04	NAME		
TOLERANCES UNLESS OTHERWISE SPECIFIED:		APVD	S.GLATFELTER	9-2-04	PIN CONTACT ASSY, SIZE 1, COAX SMA ADAPTER, ARINC 600		
0 PLC ± -		PRODUCT SPEC		SIZE		CAGE CODE	DRAWING NO
1 PLC ± -		APPLICATION SPEC		A2		00779	C=1757180
2 PLC ± -		WEIGHT		SCALE		SHEET	OF
3 PLC ± .005		CUSTOMER DRAWING		5:1		1	1
4 PLC ± -		RESTRICTED TO		REV		A	
ANGLES ± -							
FINISH							