



November 2004

H22L Series OPTOLOGIC® OPTICAL INTERRUPTER SWITCH

Features

- Black plastic housing
- Choice of inverter or buffer output functions
- Choice of open-collector or totem-pole output configuration
- No contact switching
- TTL/CMOS compatible output functions

PART NUMBER DEFINITIONS

H22LTB	Totem-pole, buffer output
H22LTI	Totem-pole, inverter output
H22LOB	Open-collector, buffer output
H22LOI	Open-collector, inverter output

Package Dimensions

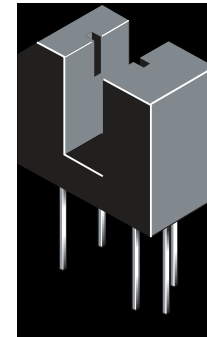
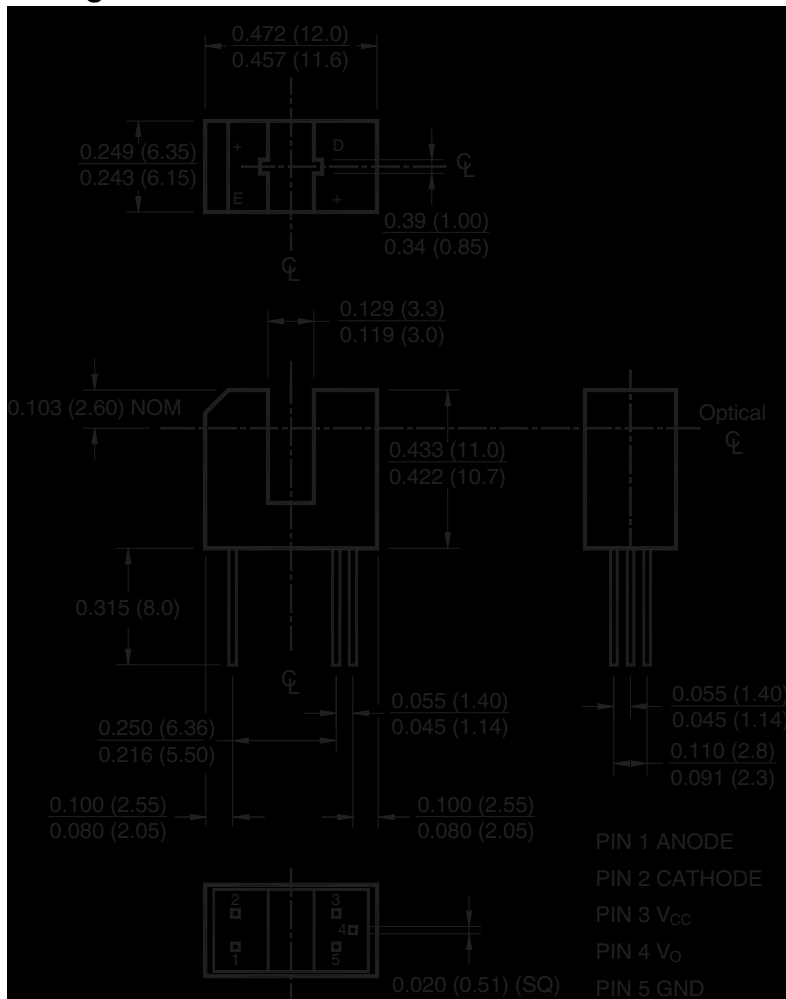

NOTES:

1. Dimensions for all drawings are in inches (millimeters).
2. Tolerance of $\pm .010$ (.25) on all non-nominal dimensions unless otherwise specified.
3. Lead cross section is controlled between .050 (1.27) from the seating plane and the end of the leads.

H22L Series OPTOLOGIC® OPTICAL INTERRUPTER SWITCH

ABSOLUTE MAXIMUM RATINGS ($T_A = 25^\circ\text{C}$ Unless otherwise specified)			
Parameter	Symbol	Rating	Units
Operating Temperature	T_{OPR}	-40 to +85	$^\circ\text{C}$
Storage Temperature	T_{STG}	-40 to +85	$^\circ\text{C}$
Soldering Temperature (Iron) ^(3,4,5,6)	T_{SOL-I}	240 for 5 sec	$^\circ\text{C}$
Soldering Temperature (Flow) ^(3,4,6)	T_{SOL-F}	260 for 10 sec	$^\circ\text{C}$
EMITTER			
Continuous Forward Current	I_F	50	mA
Reverse Voltage	V_R	5	V
Power Dissipation ⁽¹⁾	P_D	100	mW
SENSOR			
Continuous Forward Current	I_F	50	mA
Output Current	I_O	50	mA
Supply Voltage	V_{CC}	4.0 to 16	V
Output Voltage	V_O	30	V
Power Dissipation ⁽¹⁾	P_D	150	mW

ELECTRICAL / OPTICAL CHARACTERISTICS ($T_A = 25^\circ\text{C}$)						
Part Number	Test Conditions	Symbol	Min.	Typ.	Max	Units
Operating Supply Voltage	V_{CC}	V_{CC}	4.5		16	V
INPUT DIODE						
Forward Voltage	$I_F = 20\text{ mA}$	V_F	—		1.7	V
Reverse Leakage Current	$V_R = 5\text{ V}$	I_R	—		10	μA
COUPLED						
Operating Supply Current	$I_F = 15\text{ mA}$ or 0 mA , $V_{CC} = 16\text{ V}$	I_{CC}	—		5	mA
Low Level Output Voltage H22LTB, H22LOB	$I_F = 0\text{ mA}$, $V_{CC} = 5\text{ V}$, $R_L = 100\ \Omega$	V_{OL}	—		0.4	V
Low Level Output Voltage H22LTI, H22LOI	$I_F = 15\text{ mA}$, $V_{CC} = 5\text{ V}$, $R_L = 360\ \Omega$	V_{OL}	—		0.4	V
High Level Output Voltage H22LTB	$I_F = 15\text{ mA}$, $V_{CC} = 5\text{ V}$, $I_{OH} = -800\ \mu\text{A}$	V_{OH}	2.4		—	V
High Level Output Voltage H22LTI	$I_F = 0\text{ mA}$, $V_{CC} = 5\text{ V}$, $I_{OH} = -800\ \mu\text{A}$	V_{OH}	2.4		—	V
High Level Output Current H22LOB	$I_F = 0\text{ mA}$, $V_{CC} = 5\text{ V}$, $I_{OH} = -800\ \mu\text{A}$	I_{OH}			100	μA
High Level Output Current H22LOI	$I_F = 0\text{ mA}$, $V_{CC} = 5\text{ V}$, $V_{OH} = 30\text{ V}$	I_{OH}	—		100	μA
Turn on Threshold Current	$V_{CC} = 5\text{ V}$, $R_L = 360\ \Omega$	$I_{F(+)}$	—		15	mA
Turn off Threshold Current	$V_{CC} = 5\text{ V}$, $R_L = 360\ \Omega$	$I_{F(-)}$	0.50		—	mA
Hysteresis Ratio		$I_{F(+)} / I_{F(-)}$		1.3		
Propagation Delay	$V_{CC} = 5\text{ V}$, $R_L = 360\ \Omega$	t_{PLH} , t_{PHL}		5		μs
Output Rise and Fall Time	$V_{CC} = 5\text{ V}$, $R_L = 360\ \Omega$	t_r , t_f		70		ns

NOTES (Applies to Max Ratings and Characteristics Tables.):

1. Derate power dissipation linearly 1.67 mW/°C above 25°C.
2. Derate power dissipation linearly 2.50 mW/°C above 25°C.
3. RMA flux is recommended.
4. Methanol or isopropyl alcohols are recommended as cleaning agents.
5. Soldering iron 1/16" (1.6mm) from housing.
6. As long as leads are not under any stress or spring tension.

INPUT / OUTPUT TABLE		
Part Number	LED	Output
H22LTB	On	High
H22LTB	Off	Low
H22LTI	On	Low
H22LTI	Off	High
H22LOB	On	High
H22LOB	Off	Low
H22LOI	On	Low
H22LOI	Off	High

Circuit Schematics

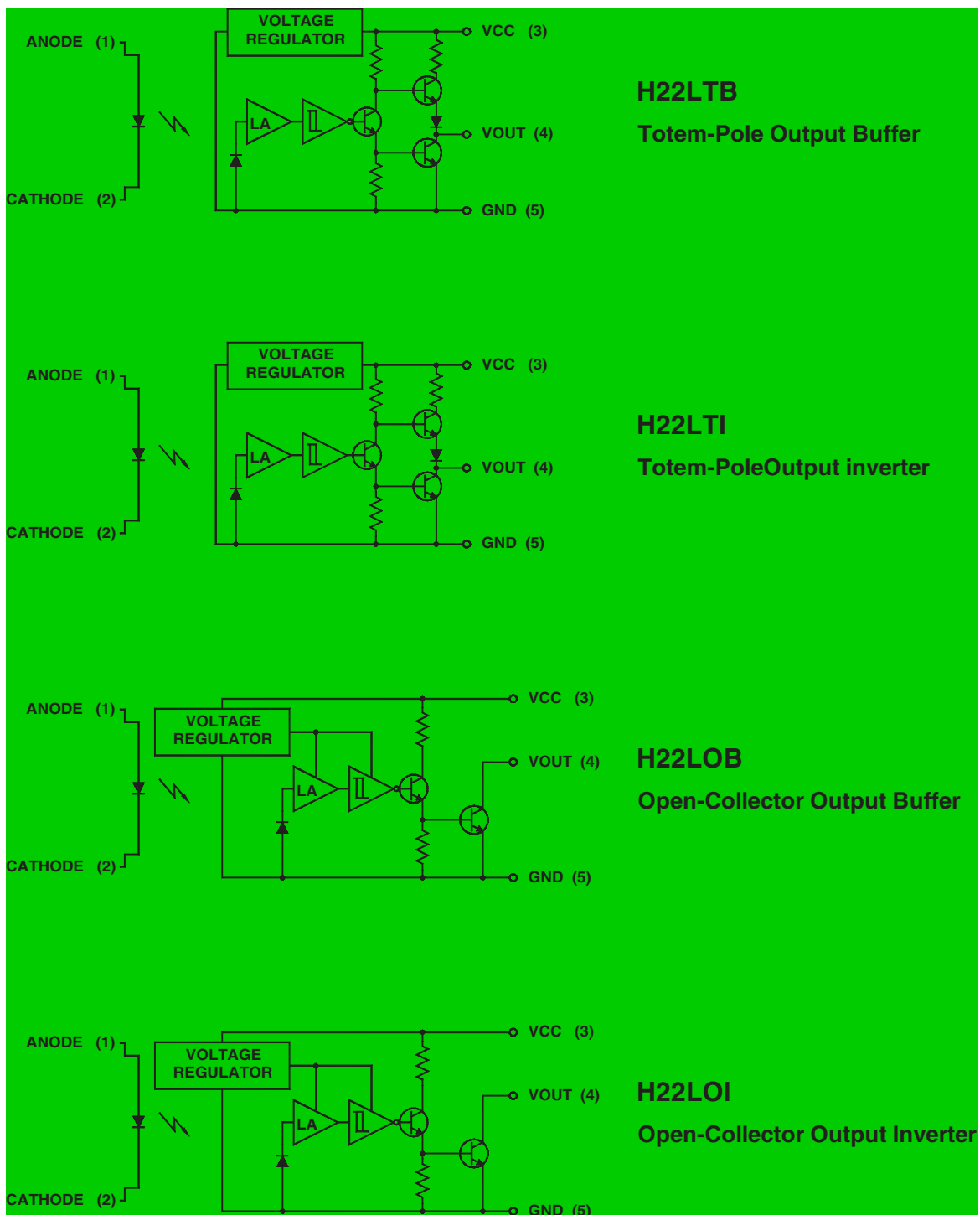

Circuit Schematics (Continued)

