



IO Expansion Shield for Launchpad V1 SKU:DFR0257



Contents

- [1 Introduction](#)
- [2 Specification](#)
- [3 Pin Out](#)
 - [3.1 More Details:](#)
- [4 Software development tools](#)
 - [4.1 Energia – A simple IDE for LaunchPad](#)
- [5 Sample code](#)

Introduction

DFRobot proudly presents the I/O expansion shield for MSP430 LaunchPad. Connect your LaunchPad with sensors, modules, servos...etc at ease. The Xbee & APC220 socket allows you to start immediately without additional wireless shield. The SPI & I2C interface enables direct plugging of modules and sensors. A well designed corner cut to make room for the test button. The colorful headers are clear to recognize and connect the digital and analog sensors.

Specification

- Support MSP430 LaunchPad
- Support Xbee/Bluetooth bee
- Support Bluetooth/APC220
- Interface: SPI, I2C
- Size: 66x50mm

Pin Out

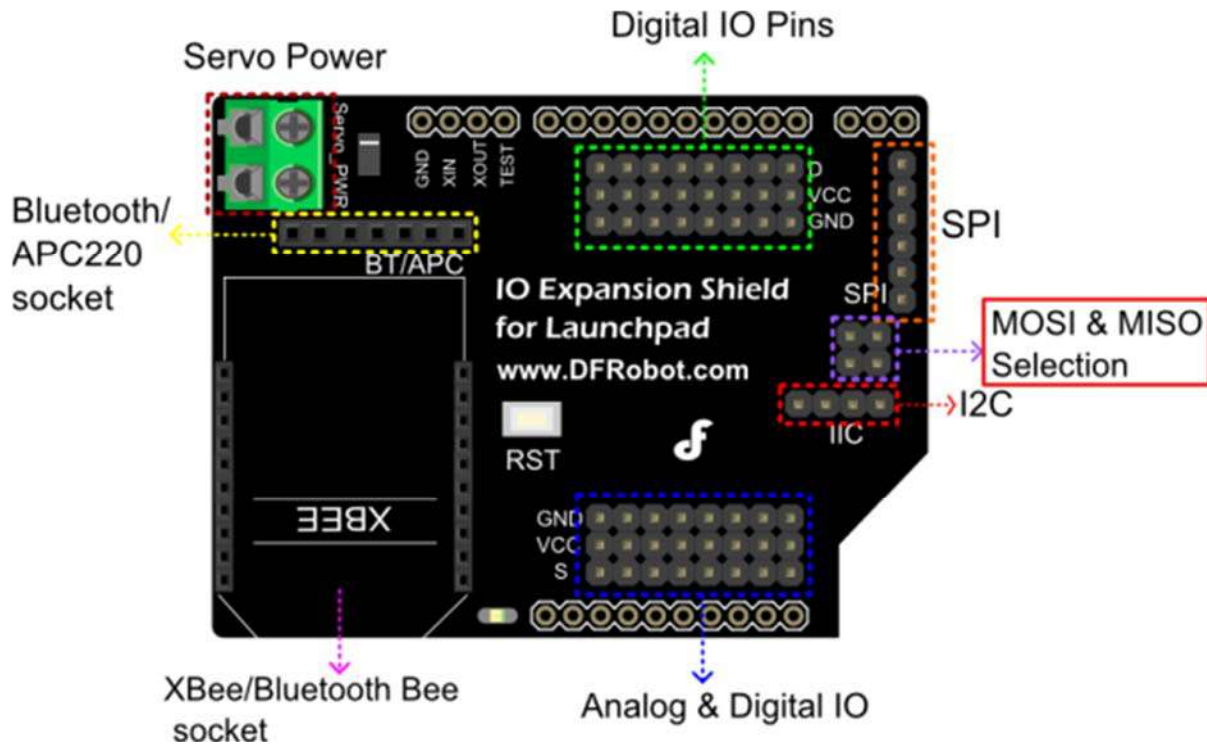

More Details:

Servo Power: Addition power to P2_0 ~ P2_7 for connecting servos.

MOSI & MISO Selection: If you want to use SPI, pay attention to which MCU you are using. Check the two jumper caps in the following image.

Detail	MCU	MOSI & MISO Selection
The two headers are for MOSI & MISO selection of different microcontroller. <i>Pay attention to which MCU you use.</i>	M430G2553	
	M430G2452	

MOSI&MISO Selection of different MCU

Software development tools

The MSP430 LaunchPad is supported by several software tools to help you lift off. Depending on your experience level, there are multiple points of entry, from beginners to professionals and anywhere in-between. Like Energia & Modkit is more friendly for beginners. Code Composer Studio, IAR Embedded Workbench for TI MSP430 are Professional software development tools.

Energia – A simple IDE for LaunchPad

Energia is an open-source electronics prototyping platform with the goal to bring the Wiring and [Arduino](#) framework to the Texas Instruments MSP430 based LaunchPad. Almost, the same IDE with Arduino. As the following image show, to the users of Arduino, this similar processing environment will be friendly, easy & quick to start your project.

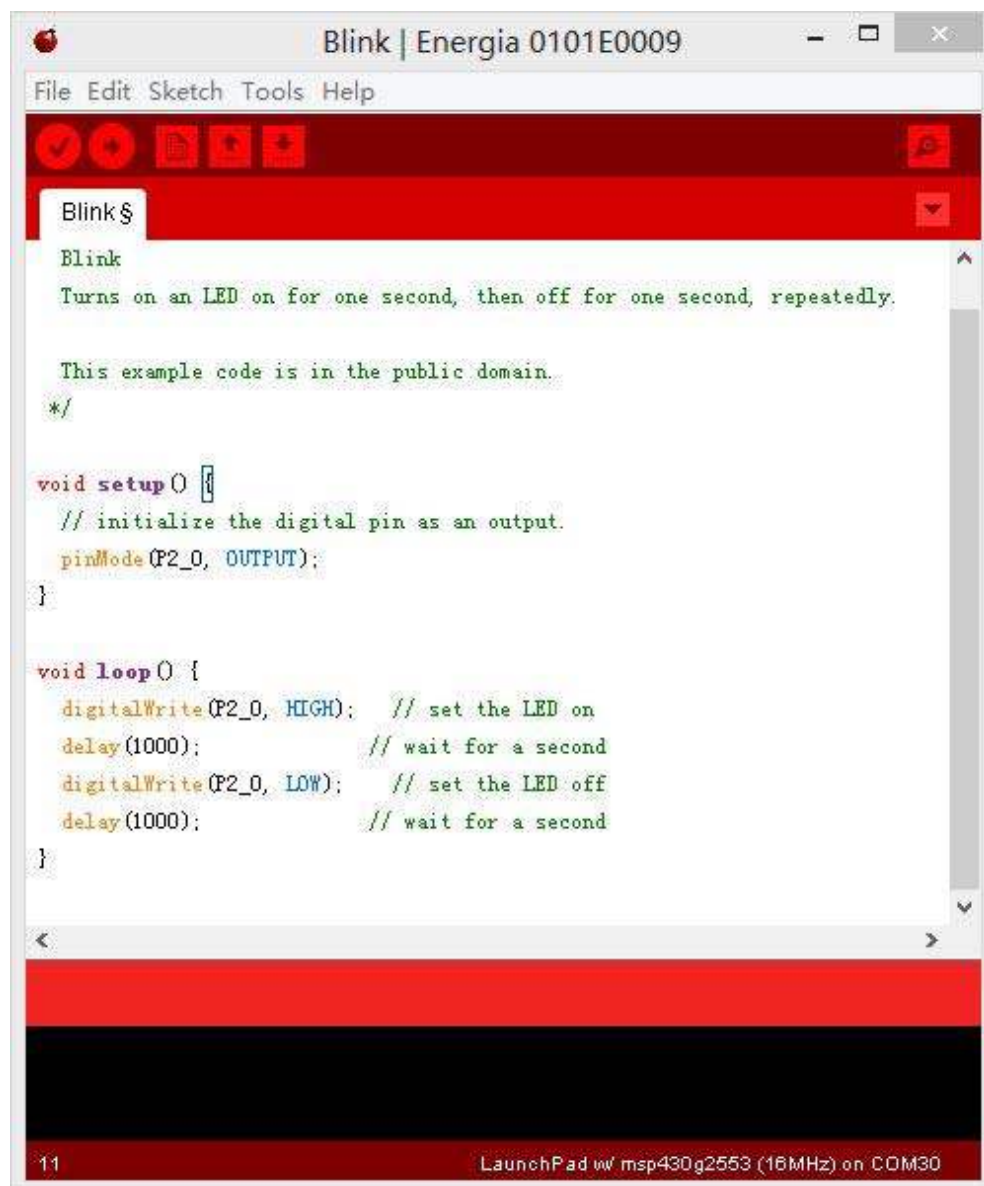
The image shows a screenshot of the Energia IDE window titled "Blink | Energia 0101E0009". The window has a menu bar with "File", "Edit", "Sketch", "Tools", and "Help". Below the menu bar is a toolbar with several icons. The main area is a text editor displaying a sketch named "Blink". The sketch includes a comment: "Blink Turns on an LED on for one second, then off for one second, repeatedly." followed by a note: "This example code is in the public domain." The code is as follows:

```
*/  
  
void setup() {  
  // initialize the digital pin as an output.  
  pinMode(P2_0, OUTPUT);  
}  
  
void loop() {  
  digitalWrite(P2_0, HIGH); // set the LED on  
  delay(1000); // wait for a second  
  digitalWrite(P2_0, LOW); // set the LED off  
  delay(1000); // wait for a second  
}
```

The bottom of the window shows a status bar with "11" on the left and "LaunchPad w/ msp430g2553 (16MHz) on COM30" on the right.

Sample code

```
/*
  Blink
  Turns on an LED on for one second, then off for one second, repeatedly.

  This example code is in the public domain.
*/

void setup() {
  // initialize the digital pin as an output.
  pinMode(P2_0, OUTPUT);
}

void loop() {
  digitalWrite(P2_0, HIGH); // set the LED on
  delay(1000);              // wait for a second
  digitalWrite(P2_0, LOW);  // set the LED off
  delay(1000);              // wait for a second
}
```