

MAXIM

MAX745 Evaluation Kit

Evaluates: MAX745

General Description

The MAX745 evaluation kit (EV kit) is an assembled and tested PC board that implements a step-down, switching power supply designed for charging lithium-ion (Li-Ion) batteries. The output voltage can be set for one to four cells. The cell voltage can be set between 4.0V and 4.4V, with 0.75% accuracy, using standard 1% resistors. Two LEDs indicate the charging status.

The MAX745 should be used to charge only Li-Ion battery packs. To charge other types of batteries, use the MAX1648 or the MAX712/MAX713. To charge SMBus™ smart-battery packs, use the MAX1645/MAX1647/MAX1667.

Component Suppliers

SUPPLIER*	PHONE	FAX
AVX	803-946-0690	803-626-3123
Dale-Vishay	402-564-3131	402-563-6418
International Rectifier	310-322-3331	310-322-3377
IRC	512-992-7900	512-992-3377
Kemet	864-963-6300	864-963-6322
Motorola	602-303-5454	602-996-6430
Murata	770-436-1300	770-436-3030
Sanyo	619-661-6835	619-661-1055
Sumida	847-956-6835	847-956-0702
TDK	847-803-6100	847-390-4405

*Please indicate that you are using the MAX745 when contacting these component suppliers.

Features

- ◆ Charges One to Four Li-Ion Cells
- ◆ Low Heat/High Efficiency
- ◆ 300kHz PWM Operation
- ◆ 0.75% Overall Accuracy over Temperature
- ◆ 6V to 24V Input Voltage Range
- ◆ Proven PC Board Layout
- ◆ Fully Assembled and Tested

Ordering Information

PART	TEMP RANGE	BOARD TYPE
MAX745EVKIT	0°C to +70°C	Surface Mount

Component List

DESIGNATION	QTY	DESCRIPTION
C1	1	68µF, 20V, 0.150Ω, low-ESR tantalum capacitor AVX TPSE686M020R0150
C2, C7, C9, C12	4	0.1µF ceramic capacitors
C3	1	47nF ceramic capacitor
C4	1	0.22µF ceramic capacitor
C5	1	4.7µF ceramic capacitor TDK C2012X5R0J475K Murata GRM21BR60J475M
C6	0	Open
C8, C10	2	150µF, 35V, 0.17Ω, aluminum electrolytic capacitors Sanyo 35CV150GX

DESIGNATION	QTY	DESCRIPTION
C11	1	1000pF ceramic capacitor
D1, D4, D6	3	3A, 40V, surface-mount Schottky diodes Motorola MBR3340T3
D2	1	1N4148-type signal diode (SOT23)
J3, J4	2	Banana jacks
JU1, JU2, JU3	3	3-pin headers
JU4	1	2-pin header
L1	1	22µH, 2.8A surface-mount inductor Sumida CDRH125-220
LED1, LED2	2	Light-emitting diodes
M1	1	2A, 30V, 0.080Ω, logic-level, dual, N-channel FET International Rectifier IRF7303

SMBus is a trademark of Intel Corp.

MAXIM

Maxim Integrated Products 1

For pricing, delivery, and ordering information, please contact Maxim/Dallas Direct! at 1-888-629-4642, or visit Maxim's website at www.maxim-ic.com.

MAX745 Evaluation Kit

Component List (continued)

DESIGNATION	QTY	DESCRIPTION
R1	1	0.100Ω ±1% sense resistor Dale WSL-2010-R1F or IRC LR2010-01-R100F
R2, R15	2	10kΩ ±5% surface-mount resistors
R3, R11, R12, R16	4	100kΩ ±1% surface-mount resistors
R4, R5, R10	0	Shorted
R6, R7	2	1kΩ ±5%, surface-mount resistors
R13	1	8kΩ ±5%, surface-mount resistor
R14	1	24Ω ±5%, surface-mount resistor
U1	1	Maxim MAX745EAP
U2	1	Maxim MAX931CSA

Quick Start

Do not turn on power until all connections are complete. Observe all precautions on the battery manufacturer's data sheet. Use only lithium-ion (Li-Ion) cells with this charger.

- 1) Set jumpers JU1 and JU2 to indicate the number of cells in the battery pack (Table 1).
- 2) Set jumper JU3 to the 2A position to enable 2A output current (Table 2).
- 3) Make sure that jumper JU4 is open to enable charger output.
- 4) Connect a DC power supply with sufficient power rating across the VIN and GND banana jacks (VIN is positive, GND is negative). DC input voltage should be between 6V and 24V.

Table 1. Configuring Number of Li-Ion Cells

NUMBER OF CELLS	VOLTAGE ADJUSTMENT RANGE	JU1 POSITION	JU2 POSITION
1	4V–4.4V	1, 2	1, 3
2	8V–8.8V	1, 2	2, 4
3	12V–13.2V	3, 4	1, 3
4	16V–17.6V	3, 4	2, 4

- 5) Connect a Li-Ion battery pack between BATT and GND (BATT is positive, GND is negative). The battery can be connected with the charger off without causing damage, or it can be connected after power is applied.
- 6) Turn on the DC power supply. Fast charging begins as soon as the battery is connected and the DC power supply is on.
- 7) When the STATUS LED turns on, the charger is operating in current-regulating mode (fast charge). When the STATUS LED turns off, the charger is operating in voltage-regulating mode (float charge).
- 8) When the DONE LED turns on, the charging current has fallen below the threshold set by R13, indicating that charging is over. The charger can be shut down by closing jumper JU4.

Detailed Description

Upon insertion, batteries are fast charged at a constant current. Batteries enter float charge when the total battery terminal voltage reaches the voltage limit.

LED2 (STATUS) indicates that the charger is in current-regulating mode. This signal can be used to detect the transition from fast charge to float charge.

LED1 (DONE) indicates that the battery current (fast charge) is below the 1.6A threshold set by R13 = 8kΩ. The IBAT output pin sources a current that is proportional to the load current, and comparator U2 detects when that load current exceeds 1.182V. R13 should not cause the IBAT voltage to exceed 2V under maximum load current. Refer to the MAX745 data sheet.

Table 2. Jumper Functions

JUMPER	STATE	FUNCTION
JU1	3, 4	CELL1 = VL; three or four cells selected.
JU1	1, 2	CELL1 = GND; one or two cells selected.
JU2	2, 4	CELL0 = VL; two or four cells selected.
JU2	1, 3	CELL0 = GND; one or three cells selected.
JU3	2A	ISET = REF; output current limited to 2A.
JU3	Open	ISET is open; output current limited to 1A.
JU3	0A	ISET = GND; output current disabled.
JU4	Open	THM = REF; output enabled.
JU4	Closed	THM = GND; output enabled.

MAX745 Evaluation Kit

Evaluates: MAX745

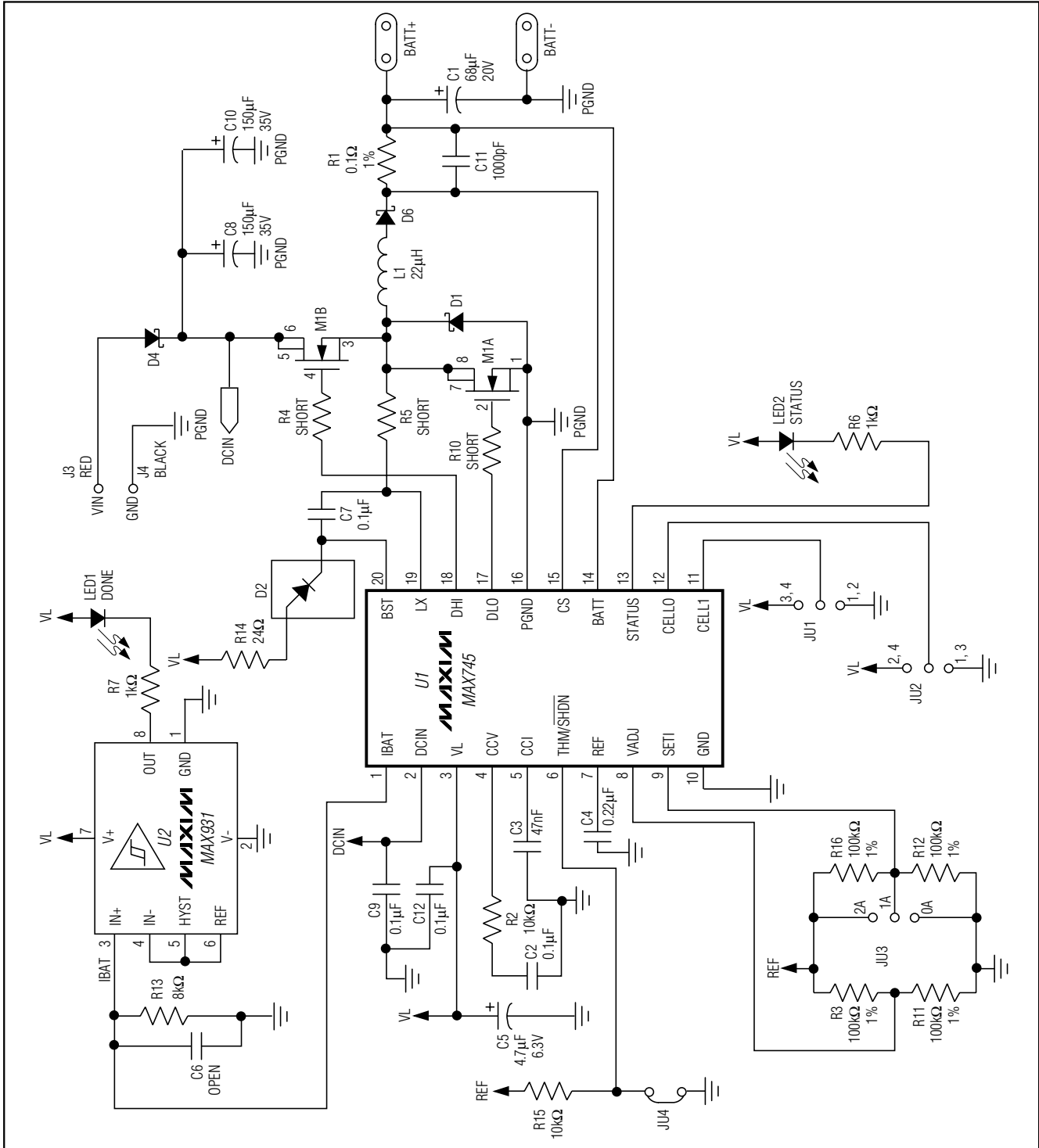

Figure 1. MAX745 EV Kit Schematic Diagram

MAX745 Evaluation Kit

Evaluates: MAX745

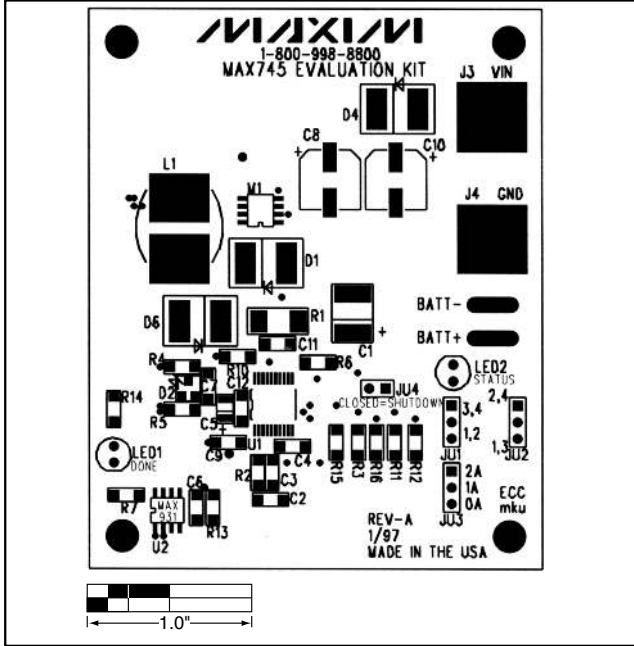

Figure 2. MAX745 EV Kit Component Placement Guide—Component Side

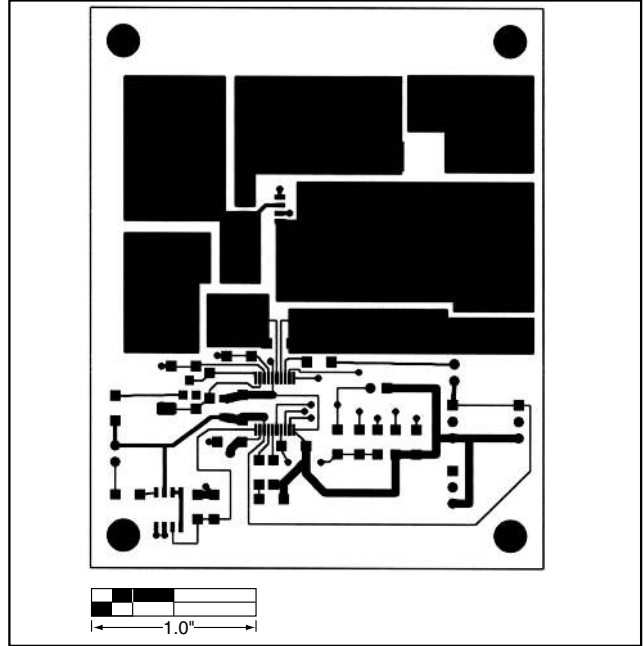

Figure 3. MAX745 EV Kit PC Board Layout—Component Side

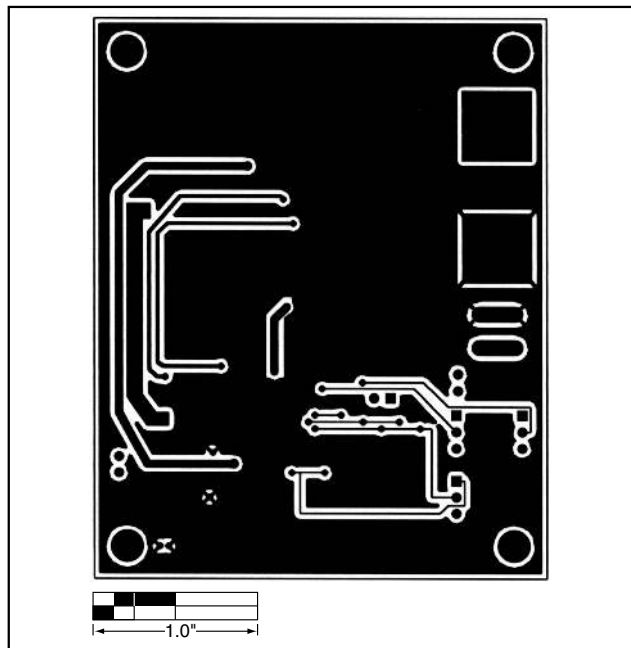

Figure 4. MAX745 EV Kit PC Board Layout—Solder Side

Maxim cannot assume responsibility for use of any circuitry other than circuitry entirely embodied in a Maxim product. No circuit patent licenses are implied. Maxim reserves the right to change the circuitry and specifications without notice at any time.

4 _____ **Maxim Integrated Products, 120 San Gabriel Drive, Sunnyvale, CA 94086 408-737-7600**