

QUICK START GUIDE FOR DEMONSTRATION CIRCUIT 829

2-PHASE DUAL STEP-DOWN CONVERTER FOR DDR/QDR MEMORY TERMINATION

LTC3776EUF

DESCRIPTION

Demonstration circuit 829 is a high efficiency 2-phase dual synchronous step-down DC/DC converter for DDR/QDR memory termination applications featuring the LTC3776EUF controller. The input voltage range of the board is from 2.75V to 8V. It has two outputs: 2.5V (5A maximum at 5V input) and 1.25V (+/-5A maximum at 5V input). The channel 2 output voltage (V_{out2}) tracks $\frac{1}{2} V_{out1}$ (V_{ref}) and is capable of providing symmetrical source/sink output current. The constant frequency current mode architecture with MOSFET V_{DS} sensing eliminates the need for sense resistors and improves efficiency. Out of phase operation significantly reduces input ripple current as well as the input capacitor size.

Switching frequency is internally set at 550KHz. The frequency can be adjusted using PLLLPF pin. Tying PLLLPF pin to GND selects 300KHz operation; tying PLLLPF pin to V_{IN} selects 750KHz operation. The switching frequency can also be externally synchronized from 250KHz to 850KHz using SYNC pin (JP1: SYNC).

The demo board can be selected to operate in spread spectrum mode (JP1: Spread Spectrum) with significantly reduced peak switching noise.

Design files for this circuit board are available. Call the LTC factory.

Table 1. Performance Summary ($T_A = 25^\circ\text{C}$)

PARAMETER	CONDITION	VALUE
Input Voltage Range		2.75V to 8V
V_{OUT1}	$V_{IN} = 2.75\text{-}8\text{V}$, $I_{OUT1} = 0\text{A to }5\text{A}$, $I_{OUT2} = 0\text{A to }5\text{A}$	$2.5\text{V} \pm 2.5\%$
V_{OUT2}	$V_{IN} = 2.75\text{-}8\text{V}$, $I_{OUT1} = 0\text{A to }5\text{A}$, $I_{OUT2} = 0\text{A to }5\text{A}$	$1.25\text{V} \pm 2.5\%$
Maximum load current I_{OUT1}	$V_{IN} = 5\text{V}$	5A
Maximum load current I_{OUT2}	$V_{IN} = 5\text{V}$	+/-5A
Typical Output Ripple V_{OUT1}	$V_{IN} = 3.3\text{V}$, $I_{OUT1} = 3\text{A}$ (20MHz BW)	20mV _{P-P}
Typical Output Ripple V_{OUT2}	$V_{IN} = 3.3\text{V}$, $I_{OUT2} = 3\text{A}$ (20MHz BW)	7mV _{P-P}
Typical Switching Frequency	PLLLPF Pin Floating; JP1:300K/550K/750KHz	550kHz
Typical Spread Spectrum Frequency Range	JP1: Spread Spectrum	450kHz- 580kHz

QUICK START PROCEDURE

Demonstration circuit 829 is easy to set up to evaluate the performance of LTC3776. Refer to Figure 1 for proper measurement equipment setup and follow the procedure below:

NOTE: When measuring the input or output voltage ripple, care must be taken to avoid a long ground lead on the oscilloscope probe. Measure the input or output voltage ripple by touching the probe tip directly

QUICK START GUIDE FOR DEMONSTRATION CIRCUIT 829

2-PHASE DUAL STEP-DOWN CONVERTER FOR DDR/QDR MEMORY TERMINATION

across the Vin or Vout and GND terminals. See Figure 2 for proper scope probe technique.

1. With power off, connect the input power supply to +Vin (2.75V-8V) and GND (input return).
2. Connect the 2.5V load (Load 1 in Figure 1) between Vout1 and GND; connect the 1.25V load (Load 2 in Figure 1) between Vout2 and GND. (Initial loads: 0 A)
3. Connect the DVMs to the input and outputs.
4. Turn on the input power supply and check for the proper output voltages. Vout1 should be 2.5V+/-2.5%. Vout2 should be 1.25V+/-2.5%.
5. Once the proper output voltages are established, adjust the loads within the operating range and observe the output voltage regulation, ripple voltage and other parameters.
6. To test sink current operation of Vout2 (1.25V), the Load 2 can be connected from Vout1 (load +) to Vout2 (load-). Please note Vout1 provides the source current for Load 2 with this set up. At 5V input, the total load current at Vout1 should not be higher than 5A.

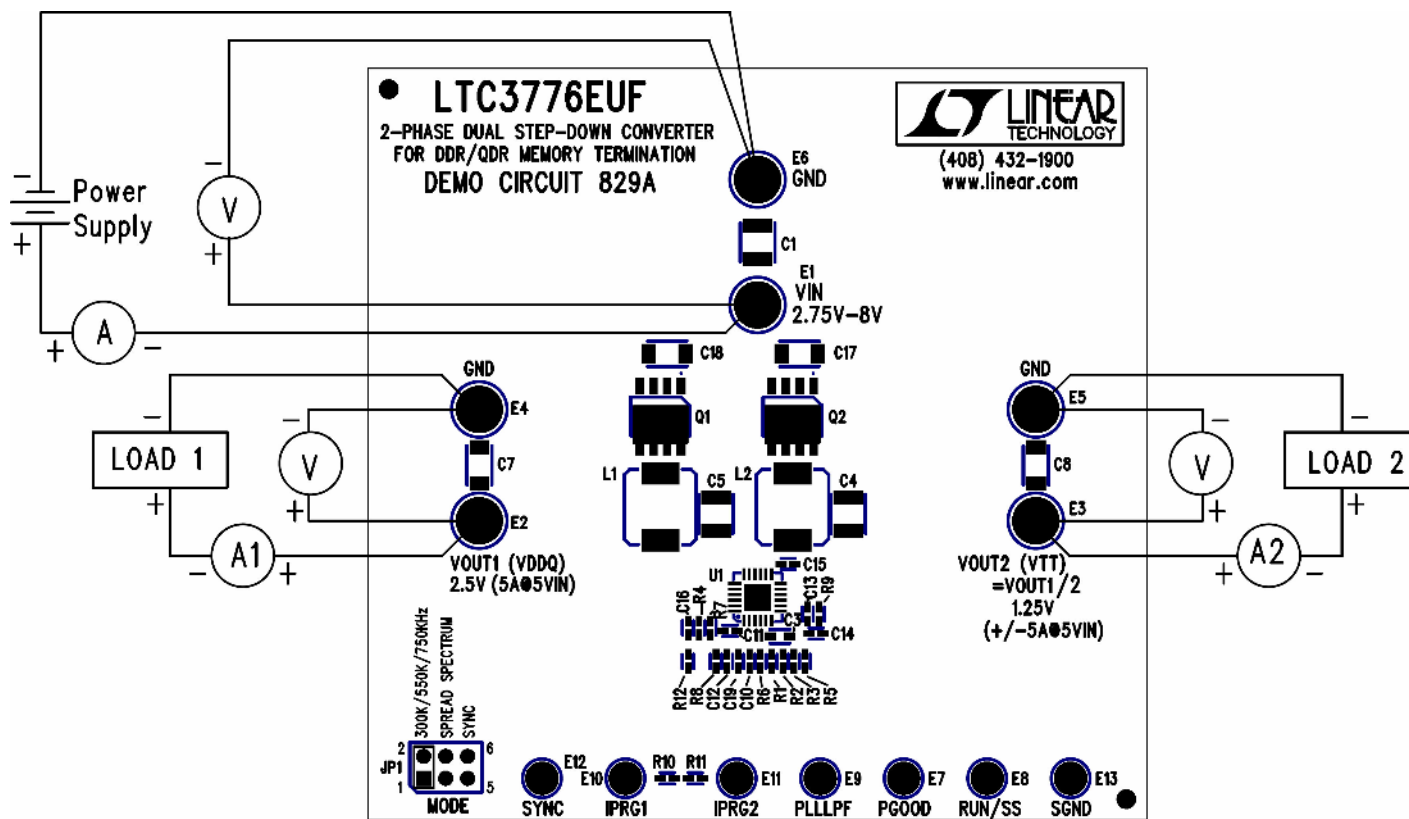

Figure 1. Proper Measurement Equipment Setup

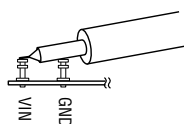

Figure 2. Measuring Input or Output Ripple

QUICK START GUIDE FOR DEMONSTRATION CIRCUIT 829

2-PHASE DUAL STEP-DOWN CONVERTER FOR DDR/QDR MEMORY TERMINATION

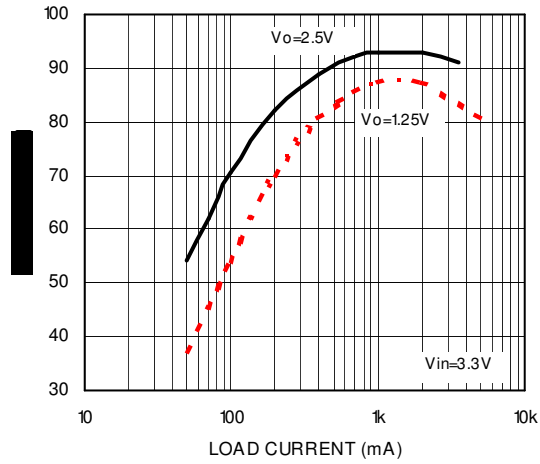
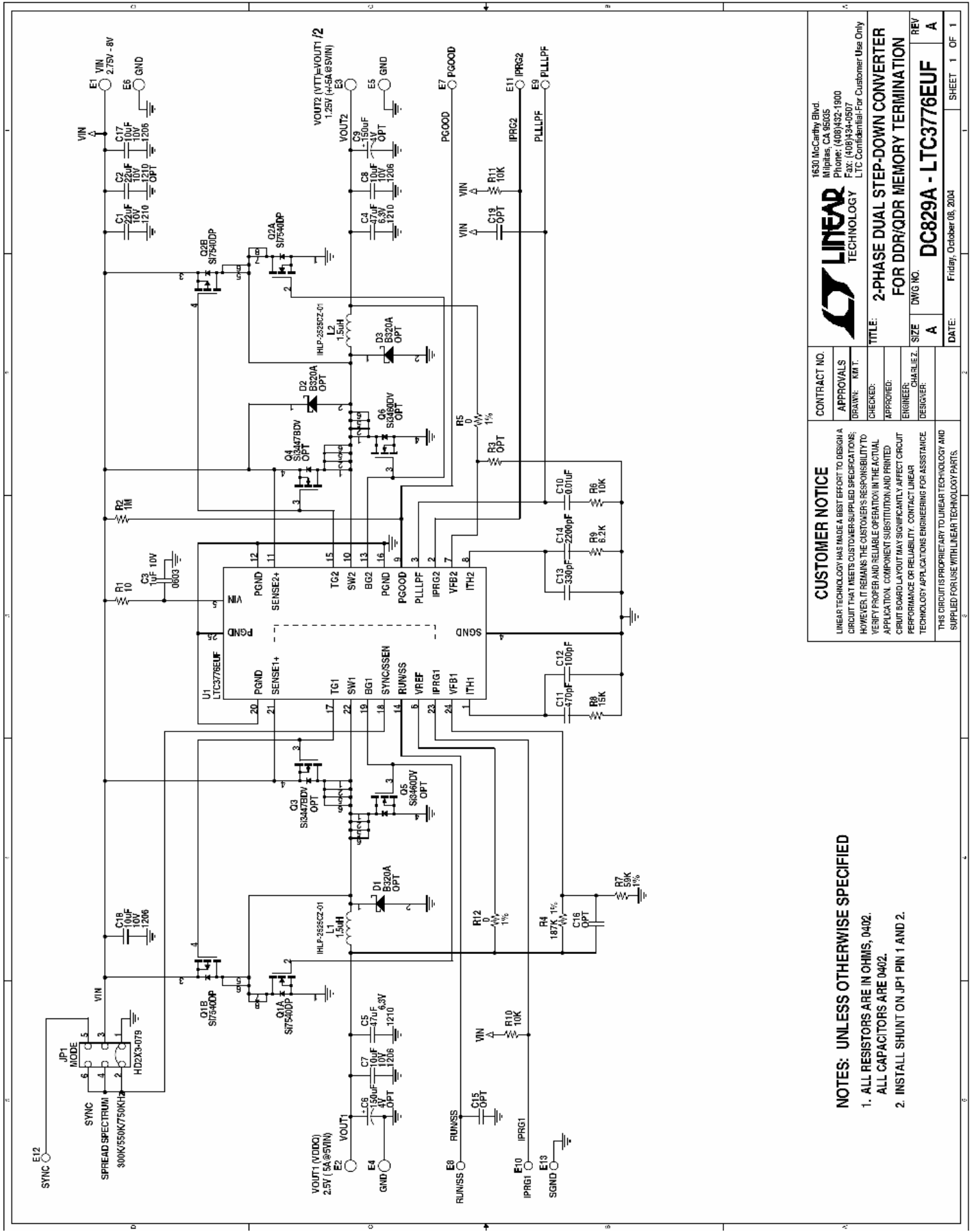

Figure 3. Efficiency vs load current (550KHz)

QUICK START GUIDE FOR DEMONSTRATION CIRCUIT 829

2-PHASE DUAL STEP-DOWN CONVERTER FOR DDR/QDR MEMORY TERMINATION



CUSTOMER NOTICE		CONTRACT NO.	
LINEAR TECHNOLOGY HAS MADE A BEST EFFORT TO DESIGN A CIRCUIT THAT MEETS CUSTOMER-SUPPLIED SPECIFICATIONS; HOWEVER, IT REMAINS THE CUSTOMER'S RESPONSIBILITY TO VERIFY PROPER AND RELIABLE OPERATION IN THE ACTUAL APPLICATION. COMPONENT SUBSTITUTION AND PRINTED CIRCUIT BOARD LAYOUT MAY SIGNIFICANTLY AFFECT CIRCUIT PERFORMANCE OR RELIABILITY. CONTACT LINEAR TECHNOLOGY APPLICATIONS ENGINEERING FOR ASSISTANCE.		APPROVALS	
THIS CIRCUIT IS PROPRIETARY TO LINEAR TECHNOLOGY AND IS SUPPLIED FOR USE WITH LINEAR TECHNOLOGY PARTS.		DRAWN: K.M.T.	
		CHECKED:	
		ENGINEER: CHARLIE Z.	
		DESIGNER:	
		DATE: Friday, October 08, 2004	
		SHEET 1 OF 1	
		1630 McCarthy Blvd. Folsom, CA 95635 Phone: (408)432-1900 Fax: (408)434-0507 LTC Confidential/For Customer Use Only	
		LINEAR TECHNOLOGY	
		TITLE: 2-PHASE DUAL STEP-DOWN CONVERTER FOR DDR/QDR MEMORY TERMINATION	
		SIZE: A	
		DWG. NO. DC829A - LTC3776EUF	
		REV: A	

NOTES: UNLESS OTHERWISE SPECIFIED

1. ALL RESISTORS ARE IN OHMS, 0402. ALL CAPACITORS ARE 0402.
2. INSTALL SHUNT ON JP1 PIN 1 AND 2.