

Ultra-low Power Integrated Ultrasonic Time-of-Flight Range Sensor Module with Particle Ingress Filter and 45° Field-of-View

MOD_CH101-03-02 HIGHLIGHTS

The MOD_CH101-03-02 is a miniature, ultra-low-power ultrasonic Time-of-Flight (ToF) range sensor module with a particle ingress filter and an acoustic housing providing a 45° field-of-view. Based on Chirp’s patented MEMS technology, the MOD_CH101-03-02 is a system-in-package device that integrates a PMUT (piezoelectric micromachined ultrasonic transducer) together with an ultra-low-power SoC (system on chip) mounted on a small PCB. The SoC runs Chirp’s advanced ultrasonic DSP algorithms and includes an integrated microcontroller that provides digital range readings via I²C.

Complementing Chirp’s long-range CH201 ultrasonic ToF sensor products, the MOD_CH101-03-02 provides accurate range measurements to targets at distances up to 1.2m (typ). Using ultrasonic measurements, the sensor works in any lighting condition, including full sunlight to complete darkness, and provides millimeter-accurate range measurements independent of the target’s color and optical transparency. Many algorithms can further process the range information for a variety of usage cases in a wide range of applications.

The MOD_CH101-03-02 can be used for Pulse-Echo applications intended for range finding and presence detection applications using a single sensor to transmit and receive ultrasonic pulses. In addition, this module can also be used for Pitch-Catch product applications using one sensor module to transmit and a second sensor module to receive the module’s frequency-matched ultrasonic pulse.

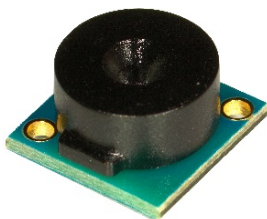

DEVICE INFORMATION

PART NUMBER	OPERATION	PACKAGE
MOD_CH101-03-02	Pitch-Catch and Pulse-Echo	8.0 x 8.0 x 5.08 mm PCBA

RoHS and Green-Compliant Package

APPLICATIONS

- Proximity/Presence sensing
- Ultra-low power remote presence-sensing nodes
- Robotics
- Obstacle avoidance
- Mobile and Computing Devices
- Augmented and Virtual Reality
- Home/Building automation

FEATURES

- Fast, accurate range-finding
 - Operating range from 4 cm to 1.2m
 - Sample rate up to 100 samples/sec
 - Programmable modes optimized for multiple range sensing applications
 - 45° field of view (FoV) acoustic housing
 - Multi-object detection
 - Works in any lighting conditions, including full sunlight to complete darkness
 - Insensitive to object color, detects optically transparent surfaces (like glass, clear plastics etc.)
- Easy to integrate
 - Single sensor for receive and transmit
 - Single 1.8V supply
 - I²C Fast-Mode compatible interface, data rates up to 400 kbps
 - Dedicated programmable range interrupt pin
 - Platform-independent software driver enables turnkey range-finding
- Miniature integrated module
 - 8.0 mm x 8.0 mm square x 5.08 mm module
 - Easy connection via 8-pin ZIF FFC/FPC connector
 - Integrated SAATI Acoustex B042HY Particle Ingress Filter (PIF) providing IP5x dust protection
 - Low-power SoC running advanced ultrasound firmware
- Operating temperature range: -40°C to 85°C
- Ultra-low supply current
 - 1 sample/s:
 - 13 μA (10 cm max range)
 - 15 μA (1.0m max range)
 - 30 samples/s:
 - 20 μA (10 cm max range)
 - 50 μA (1.0m max range)

Table of Contents

MOD_CH101-03-02 Highlights	1
Device Information	1
Applications	1
Features	1
1 MOD_CH101-03-02 Schematic	3
1.1 Module Integration	3
2 Pin Description (Module ZIF Connector J1).....	4
3 Package Dimensions.....	5
3.1 Package Connector Orientation	5
3.2 Package Information	5
4 Electrical Characteristics	6
5 Applications:	7
5.1 Object Detection	7
5.2 Beam Pattern	7
6 Ordering Information.....	8
6.1 Part Number Designation.....	8
6.2 Package Marking	8
6.3 Tray Packaging Specification	9
6.4 Shipping Label	10
7 Revision History	11

1 MOD_CH101-03-02 SCHEMATIC

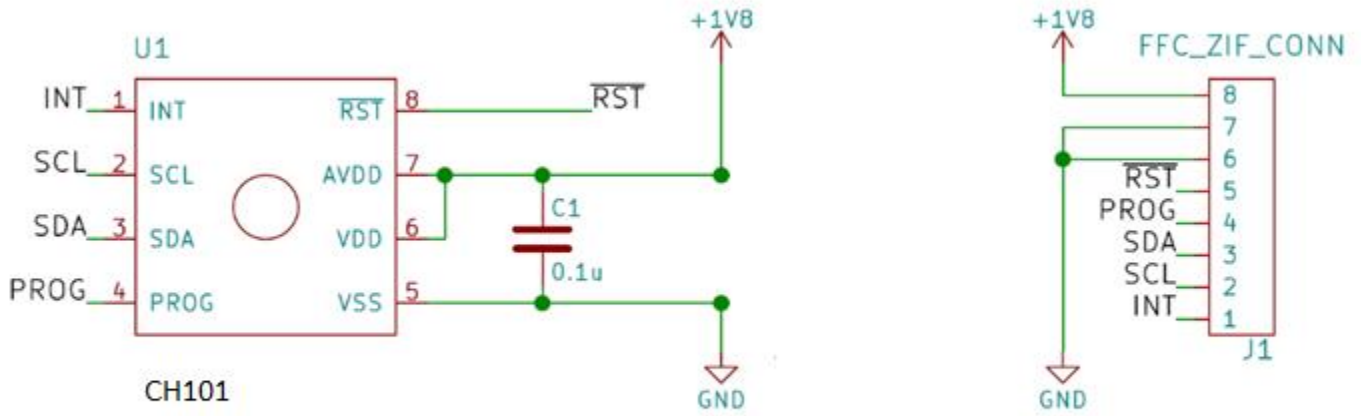

Figure 1. Module Schematic

1.1 MODULE INTEGRATION

Electrical connection to the CH101 module is via an 8-pin 0.5 mm pitch flat flex cable (FFC) connector. Part numbers of the FFC connectors on the module PCB and the recommended FFC cables are shown in Table 1. The electrical schematic of the module, including the connector pinout and the connections to the CH101 sensor, is shown in Figure 1. Note that the 0.1 µF decoupling capacitor, as recommended in the CH101 datasheet, is included in the module. Consult the DS-000331 CH101 datasheet and application notes for additional information on electrical connection and operation of the CH101 sensor.

In Figure 2, the MOD_CH101-03-02 is shown connected through a flat flex cable. Each CH101 requires its own PROG line and INT line. The remaining connections can be shared. (Refer to the CH101 datasheet for additional information.)

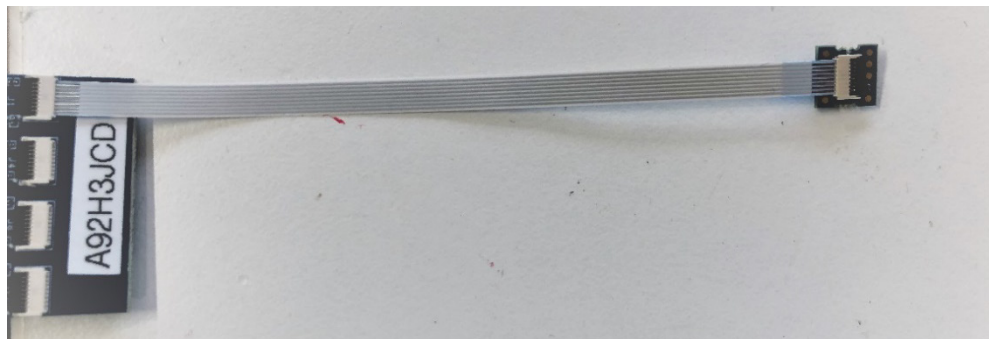

Figure 2. MOD_CH101-03-02 Connection

FLAT CABLE CONNECTOR TYPE	Molex 503480-0800
RECOMMENDED FLAT CABLE	Molex 151660073...151660094

Table 1. Recommended Flat Flex Cable and Connector

2 PIN DESCRIPTION (MODULE ZIF CONNECTOR J1)

PIN	NAME	DESCRIPTION
1	INT	Interrupt output. Can be switched to input for triggering and calibration functions.
2	SCL	SCL Input. I ² C clock input. This pin must be pulled up to VDD externally.
3	SDA	SDA Input/Output. I ² C data I/O. This pin must be pulled up to VDD externally.
4	PROG	Program Enable. This pin must be pulled down to ground externally.
5	RESET_N	Active-low reset. This pin must be pulled up to VDD externally.
6	VSS	Power return.
7	VSS	Power return.
8	VDD	Power supply input. Connect to externally regulated 1.8V supply.

Table 2. Pin descriptions

3 PACKAGE DIMENSIONS

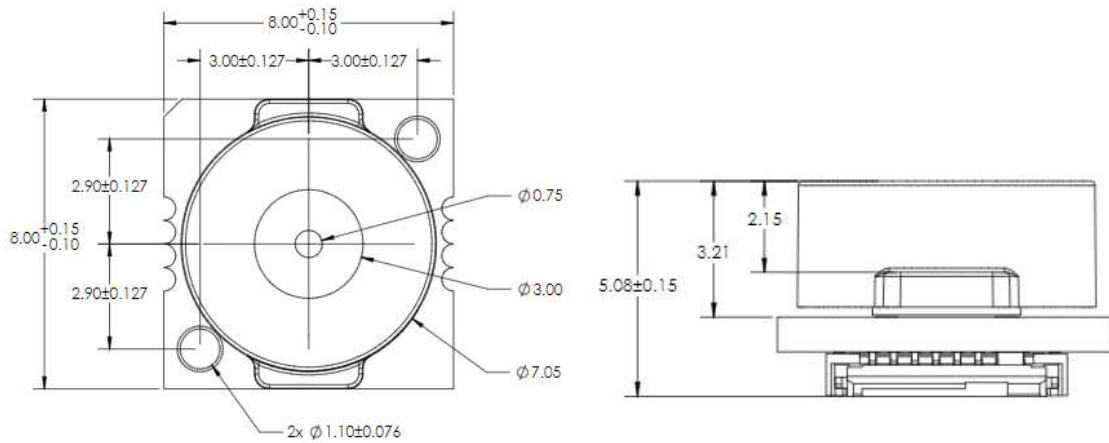

Figure 3. Module Dimensions

3.1 PACKAGE CONNECTOR ORIENTATION

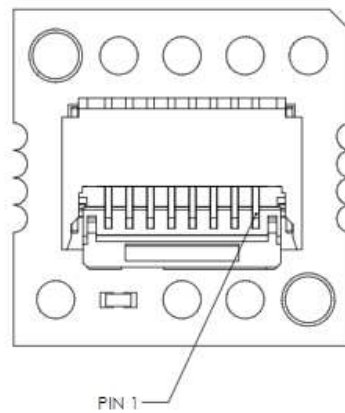

Figure 4. Module Connector Orientation

3.2 PACKAGE INFORMATION

DESCRIPTION	DOCUMENT NUMBER
CH101 Mechanical Integration Guide	AN-000158

Table 3. Package information

4 ELECTRICAL CHARACTERISTICS

Please refer to DS-000331 CH101 datasheet for information on the device's electrical characteristics.

5 APPLICATIONS:

5.1 OBJECT DETECTION

Detecting the presence of objects or people can be optimized via software by setting the sensor’s full-scale range (FSR). The user may set the maximum distance at which the sensor will detect an object. FSR values refer to the one-way distance to a detected object.

In practice, the FSR setting controls the amount of time that the sensor spends in the listening (receiving) period during a measurement cycle. Therefore, the FSR setting affects the time required to complete a measurement. Longer full-scale range values will require more time for a measurement to complete.

Ultrasonic signal processing using the MOD_CH101-03-02’s General Purpose Rangefinder (GPR) Firmware will detect echoes that bounce off the first target in the Field-of-View. The size, position, and material composition of the target will affect the maximum range at which the sensor can detect the target. Large targets, such as walls, are much easier to detect than smaller targets. Thus, the associated operating range for smaller targets will be shorter. The range to detect people will be affected by a variety of factors such as a person’s size, clothing, orientation to the sensor, and the sensor’s field-of-view. In general, given these factors, people can be detected at a maximum distance of 0.7m away from the MOD_CH101-03-02 sensor.

5.2 BEAM PATTERN

Typical Beam Pattern – MOD_CH101-03-02 with a 45° FoV acoustic housing module
 (Measured with a 1m² flat plate target at a 30 cm range)

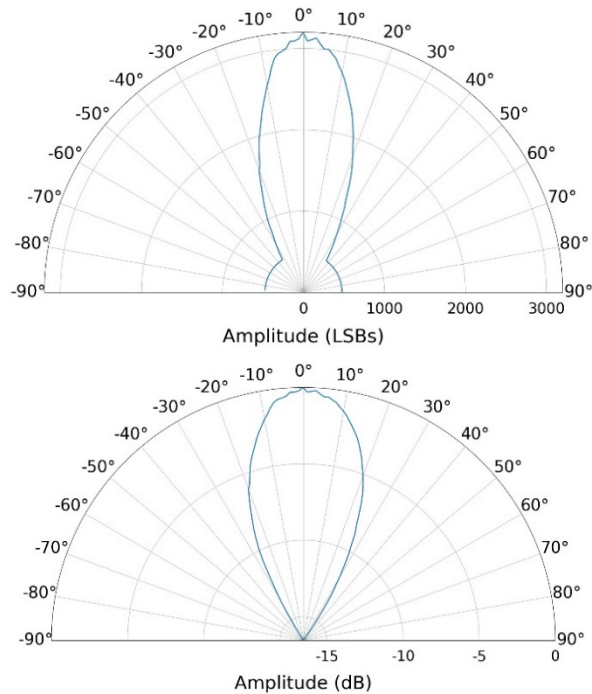

Figure 5. MOD_CH101-03-02 Beam pattern measurements

6 ORDERING INFORMATION

6.1 PART NUMBER DESIGNATION

This datasheet specifies the following part numbers:

PART NUMBER	OPERATION	PACKAGE BODY	QUANTITY	PACKAGING
MOD_CH101-03-02	Pulse-Echo Pitch-Catch	8.0 mm x 8.0 mm x 5.08 mm	165	Custom Tray

6.2 PACKAGE MARKING

Device: MOD_CH101-03-02

Year: YY

Work Week: WW

Day: D

Lot Number: NNNN

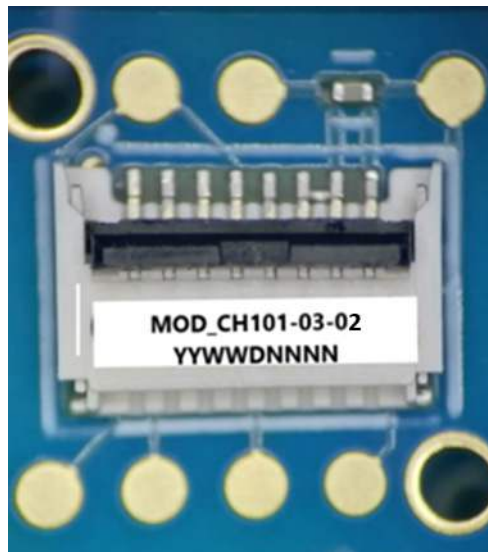

Figure 6. Example Package Marking

6.3 TRAY PACKAGING SPECIFICATION

Custom tray packages shall be used to ship devices in. The nominal tray dimensions are 225 mm x 275 mm x 13 mm height. The package carrier holds 165 devices maximum.

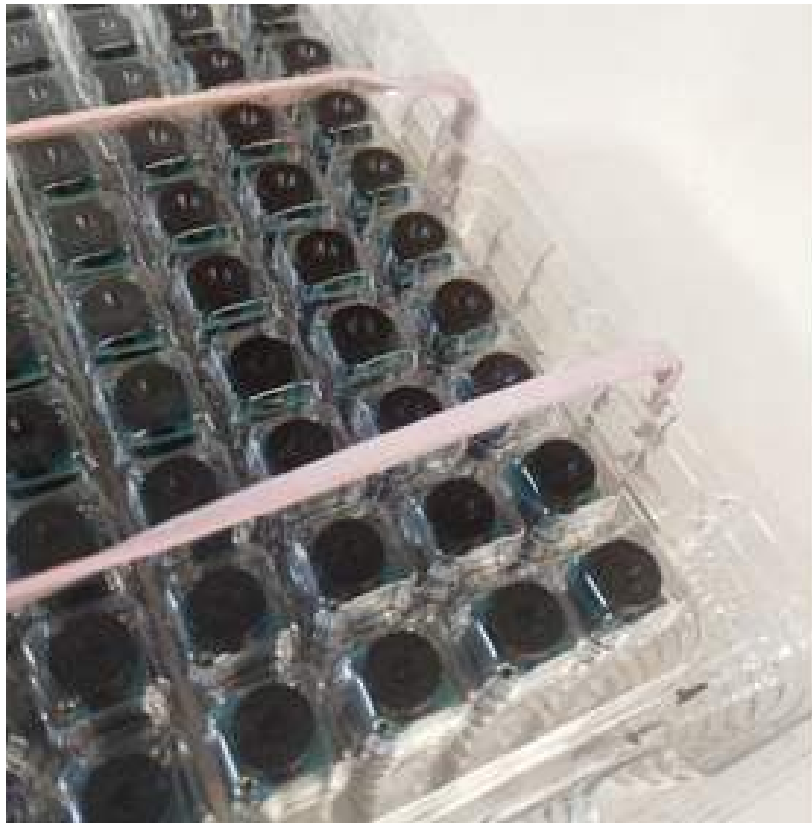

Figure 7. Tray Packaging

6.4 SHIPPING LABEL

A Shipping Label will be attached to the bag and box. The information provided on the label is as follows:

Device: This is the full part number

Lot Number: Chirp manufacturing lot number

Date Code: Date the lot was sealed in the moisture proof bag

Quantity: Number of components in the tray

2D Barcode: Contains Lot No., quantity and bag/box number

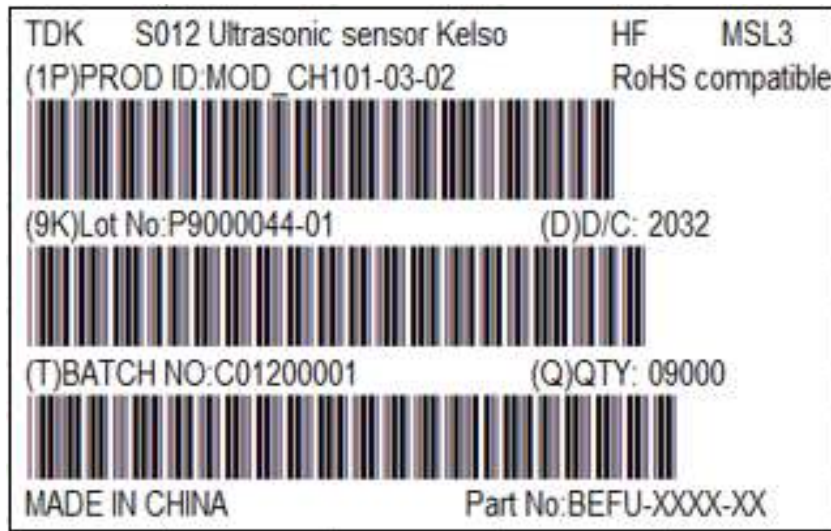

Figure 8. Tray Packaging

7 REVISION HISTORY

DATE	REVISION	CHANGES
08/10/2020	1.0	Initial Release

This information furnished by Chirp Microsystems, Inc. ("Chirp Microsystems") is believed to be accurate and reliable. However, no responsibility is assumed by Chirp Microsystems for its use, or for any infringements of patents or other rights of third parties that may result from its use. Specifications are subject to change without notice. Chirp Microsystems reserves the right to make changes to this product, including its circuits and software, in order to improve its design and/or performance, without prior notice. Chirp Microsystems makes no warranties, neither expressed nor implied, regarding the information and specifications contained in this document. Chirp Microsystems assumes no responsibility for any claims or damages arising from information contained in this document, or from the use of products and services detailed therein. This includes, but is not limited to, claims or damages based on the infringement of patents, copyrights, mask work and/or other intellectual property rights.

Certain intellectual property owned by Chirp Microsystems and described in this document is patent protected. No license is granted by implication or otherwise under any patent or patent rights of Chirp Microsystems. This publication supersedes and replaces all information previously supplied. Trademarks that are registered trademarks are the property of their respective companies. Chirp Microsystems sensors should not be used or sold in the development, storage, production or utilization of any conventional or mass-destructive weapons or for any other weapons or life threatening applications, as well as in any other life critical applications such as medical equipment, transportation, aerospace and nuclear instruments, undersea equipment, power plant equipment, disaster prevention and crime prevention equipment.

©2020 Chirp Microsystems. All rights reserved. Chirp Microsystems and the Chirp Microsystems logo are trademarks of Chirp Microsystems, Inc. The TDK logo is a trademark of TDK Corporation. Other company and product names may be trademarks of the respective companies with which they are associated.