

QT-Brightek Lamp Series
5mm Bi-Color Round Lamp

Part No.: QBL8RAG30D1

30: Viewing Angle 30 Deg Typical
D: White Diffused Lens
1: Common Cathode

Product: QBL8RAG30D1	Date: June 24 th , 2022	Page 1 of 8
	Version# 1.1	



Table of Contents:

Introduction3
Electrical / Optical Characteristic (Ta=25 °C)4
Absolute Maximum Rating4
Characteristic Curves.....5
Ordering Information7
Revision History8
Disclaimer8

Introduction

Feature:

- White diffused lens
- Bi-Color Red (R) 624nm + Green (AG) 570nm
- Package in bulk pack
- Super bright 5mm round lamp
- AllnGaP technology
- Viewing angle: 30° typ.
- 1: Common cathode

Description:

These super bright 5mm round type lamps with 8.6mm lens height are suitable for all applications requiring higher brightness.

Application:

- General purpose indicator application
- Electronic signs and electronics board
- LED lighting

Certification & Compliance:

- ISO9001
- RoHS Compliant



Dimension:

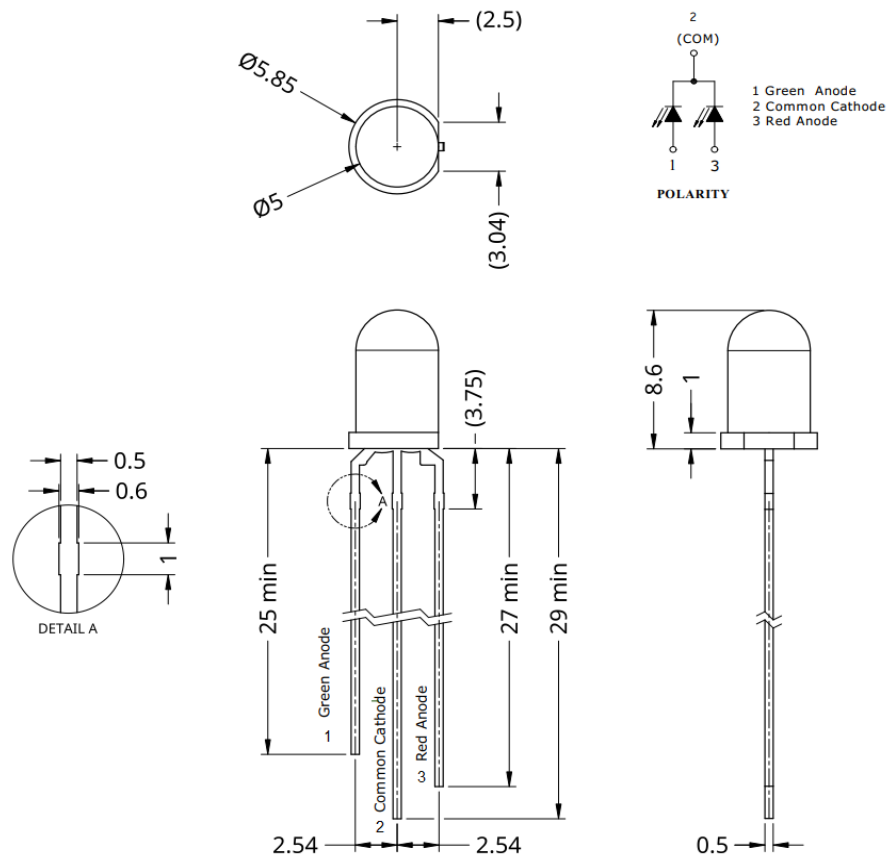

Units: mm / Unidentified tolerance = +/-0.25mm

Electrical / Optical Characteristic (Ta=25°C)

Product	Color	I _F (mA)	V _F (V)		λ _D (nm)	λ _P (nm)	I _V (mcd)	
			Typ.	Max.	Typ.	Typ.	Min.	Typ.
QBL8RAG30D1	Red	20	2.0	2.4	624	632	600	1000
	Green		2.0	2.4	570	573	210	350

Absolute Maximum Rating

Material	P _d (mW)	I _F (mA)	I _{FP} (mA)*	V _R (V)	T _{OP} (°C)	T _{ST} (°C)	T _{SOL} (°C)**
AllnGaP	60	25	100	5	-40 to +85	-40 to +100	260

*Duty Factor =10% @ 1KHz

**Wave soldering for no more than 5 sec @ 260 °C

Characteristic Curves

Red (R)

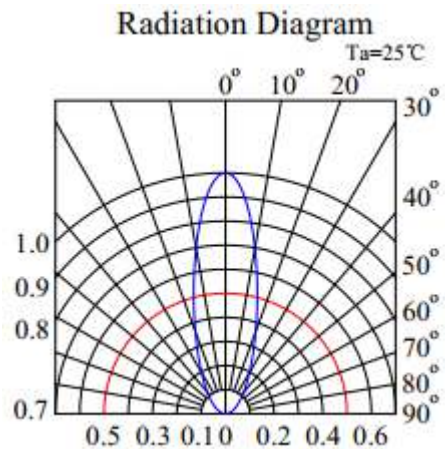
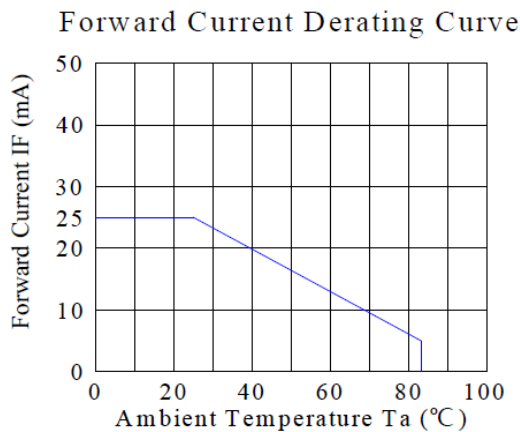
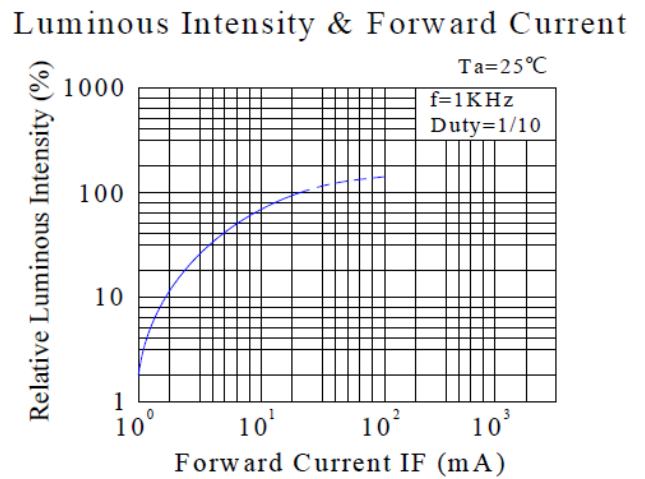
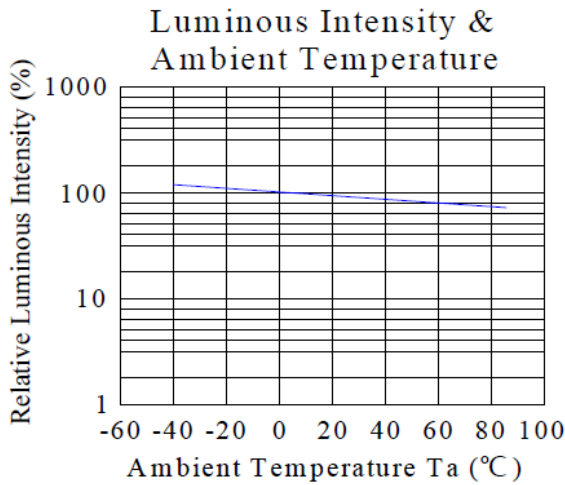
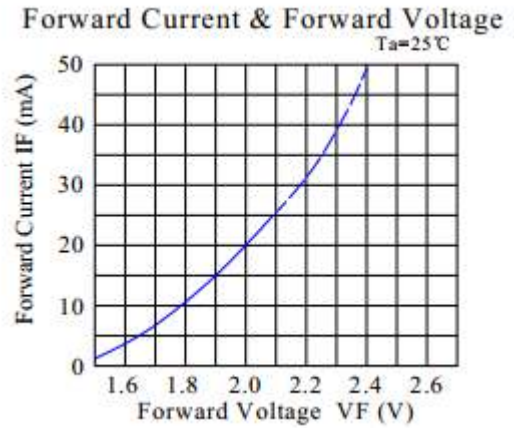
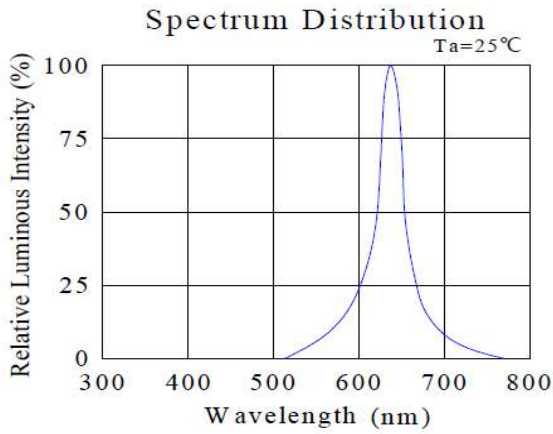

Green (AG)

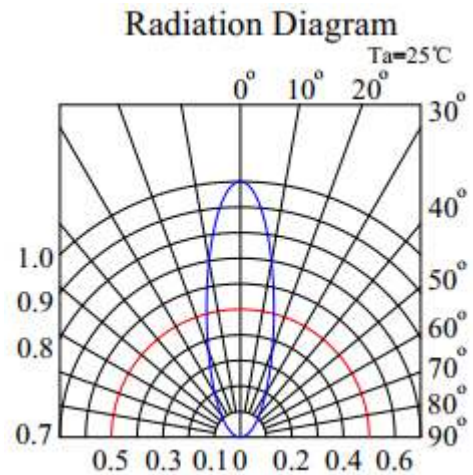
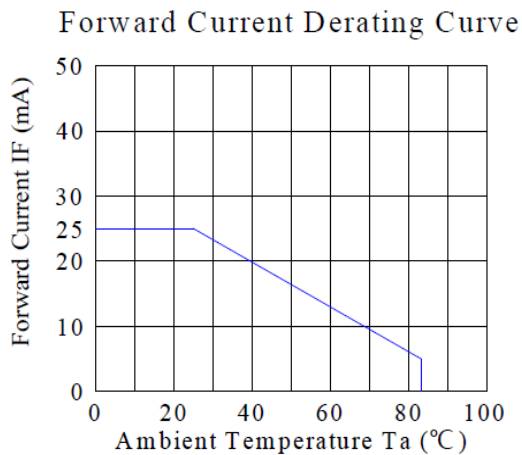
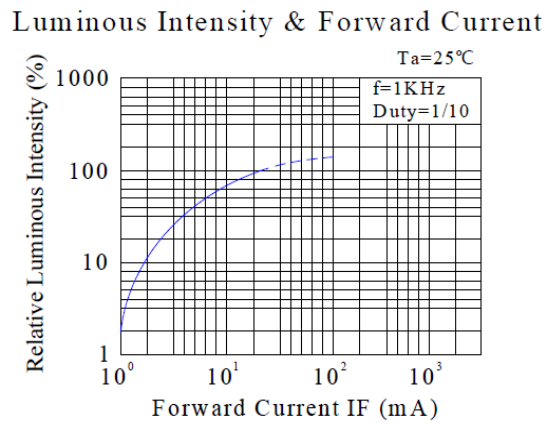
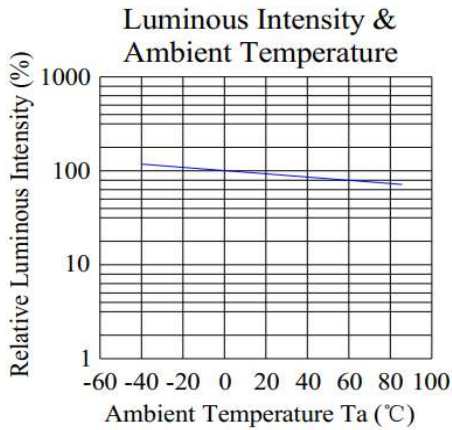
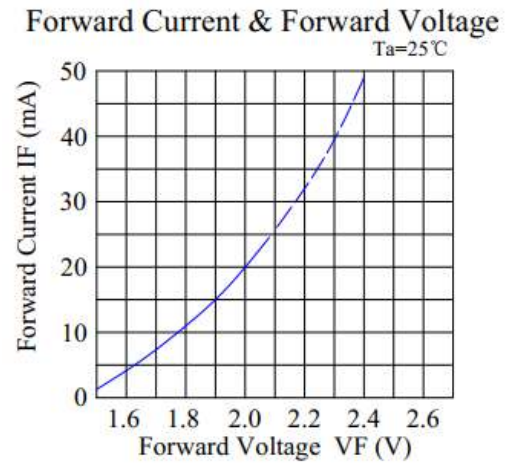
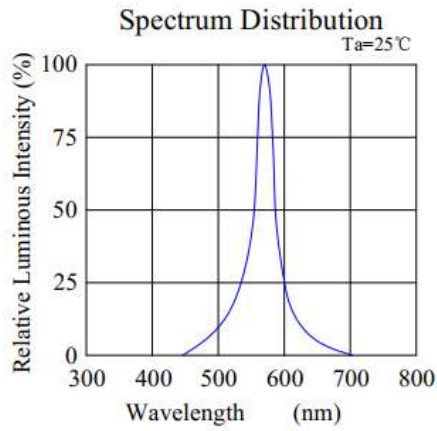



QBL8RAG30D1

5mm Bi-Color Round Lamp

Ordering Information

Part #	Orderable Part #	Spec Range	Quantity per bag
QBL8RAG30D1	QBL8RAG30D1	Red: $I_v=1000\text{mcd typ. @ } I_F=20\text{mA, } \lambda_D=624\text{nm typ.}$	500pcs
		Yellow Green: $I_v=350\text{mcd typ. @ } I_F=20\text{mA, } \lambda_D= 570\text{nm typ.}$	



Revision History

Description:	Revision #	Revision Date
New Release of QBL8RAG30D1	V1.0	07/18/2020
Drawing Update	V1.1	06/24/2022

Disclaimer

QT-BRIGHTTEK reserves the right to make changes without further notice to any products herein to improve reliability, function or design. QT-BRIGHTTEK does not assume any liability arising out of the application or use of any product or circuit described herein; neither does it convey any license under its patent rights, nor the rights of others.

Life Support Policy

QT-BRIGHTTEK's products are not authorized for use as critical components in life support devices or systems without the express written approval of QT-BRIGHTTEK. As used herein:

1. Life support devices or systems are devices or systems which, (a) are intended for surgical implant into the body, or (b) support or sustain life, and (c) whose failure to perform when properly used in accordance with instructions for use provided in the labeling, can be reasonably expected to result in a significant injury of the user.
2. A critical component in any component of a life support device or system whose failure to perform can be reasonably expected to cause the failure of the life support device or system, or to affect its safety or effectiveness.