



XR46010 Product Brief

Active Load Current Regulator for Phase-Cut Dimmable AC Direct Drive LED Lamp

Description

The XR46010 is an active load current regulator for phase-cut dimmable AC direct drive LED lamp system. The active load circuit can provide the holding current for TRIAC and also the charging current path of R/C circuit in a dimmer. It can help to stabilize TRIAC operation and increase the dimming range of the lamp system.

The application of the XR46010 is configured in parallel with an LED string. It conducts the current when the LED string is in off state, and stops conducting the current when the LED string is in on state.

The active load circuit can be placed in the same board with the LED string or a separate board in front of the LED board. The design is very flexible to meet various shape requirements.

FEATURES

- 3V to 80V input operation range
- 250mV low current sense voltage
- Linear over temperature protection

APPLICATIONS

- LED Lighting Applications
 - Downlight
 - High bay
 - Specialty
 - Architectural

Typical Application

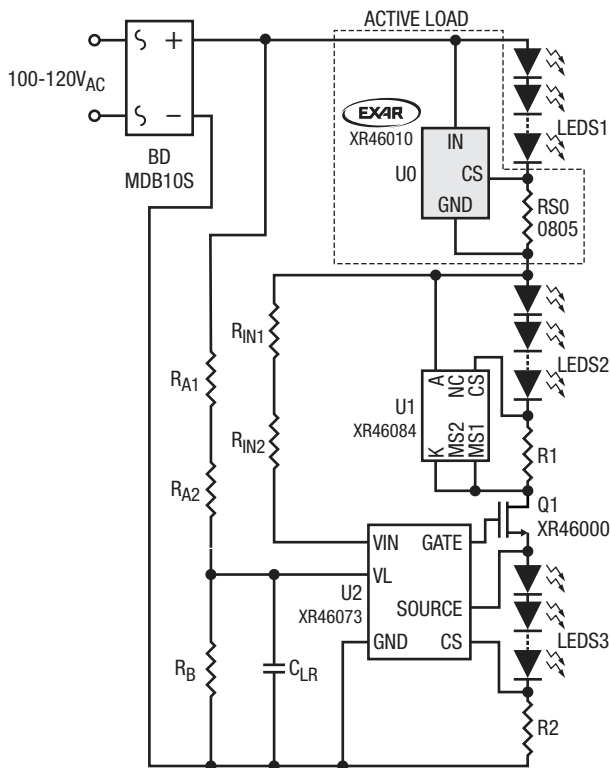

Pin Configuration

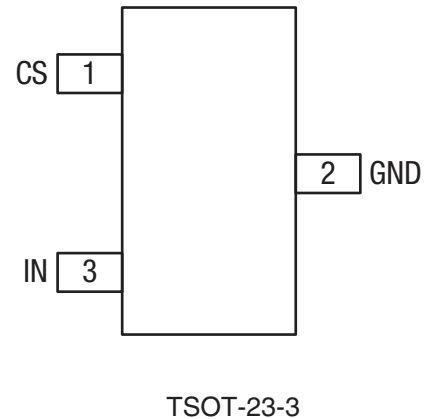

Ordering Information⁽¹⁾

Part Number	Junction Temperature Range	Lead-Free	Package	Packaging Method
XR46010ISBTR	$-40^{\circ}\text{C} \leq T_J \leq 150^{\circ}\text{C}$	Yes ⁽²⁾	TSOT-23-3L	Tape and reel

NOTE:

1. Refer to www.exar.com/XR46010 for most up-to-date Ordering Information.
2. Visit www.exar.com for additional information on Environmental Rating.

Please contact LEDtechsupport@exar.com to request a complete datasheet.



www.exar.com

48720 Kato Road
Fremont, CA 94538
USA

Tel.: +1 (510) 668-7000
Fax: +1 (510) 668-7001
Email: LEDtechsupport@exar.com

Exar Corporation reserves the right to make changes to the products contained in this publication in order to improve design, performance or reliability. Exar Corporation conveys no license under any patent or other right and makes no representation that the circuits are free of patent infringement. While the information in this publication has been carefully checked, no responsibility, however, is assumed for inaccuracies.

Exar Corporation does not recommend the use of any of its products in life support applications where the failure or malfunction of the product can reasonably be expected to cause failure of the life support system or to significantly affect its safety or effectiveness. Products are not authorized for use in such applications unless Exar Corporation receives, in writing, assurances to its satisfaction that: (a) the risk of injury or damage has been minimized; (b) the user assumes all such risks; (c) potential liability of Exar Corporation is adequately protected under the circumstances.

Reproduction, in part or whole, without the prior written consent of Exar Corporation is prohibited. Exar, XR and the XR logo are registered trademarks of Exar Corporation. All other trademarks are the property of their respective owners.