

5 CIRCUIT SHOWN

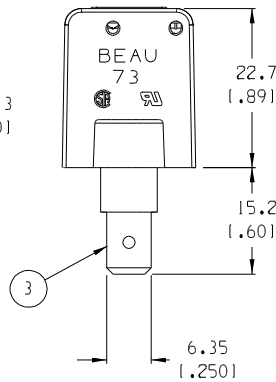
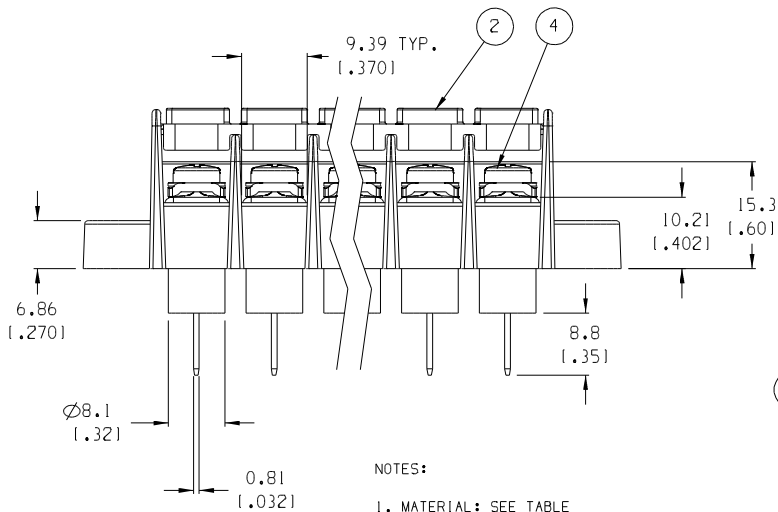

NOTES:

1. MATERIAL: SEE TABLE
2. FINISHES: SEE TABLE
3. PRODUCT SPECIFICATION: NOT REQUIRED
4. PACKAGING: NOT REQUIRED
5. MATES WITH: NONE
6. "XX" REFERS TO THE QUANTITY OF CIRCUITS.

# OF CIRC. "XX"	DIM. "A"	DIM. "B"	DIM. "C"	DIM. "D"	ASSEMBLY MATERIAL NO.		
02	43.5	11.711	11.11	1.4381	33.34 (1.3131)	24.5 (1.971)	387390588
03	54.6	12.151	22.23	1.8751	44.45 (1.7501)	35.7 (1.401)	
04	65.7	12.591	33.34	1.3131	55.56 (2.1881)	46.8 (1.841)	
05	76.8	13.031	44.45	1.7501	66.68 (2.6251)	57.9 (2.281)	
06	87.9	13.461	55.56	2.1881	77.79 (3.0631)	69.0 (2.721)	
07	99.1	13.901	66.68	2.6251	88.90 (3.5001)	80.1 (3.151)	
08	110.2	14.341	77.79	3.0631	100.01 (3.9381)	91.2 (3.591)	
09	121.3	14.781	88.90	3.5001	111.13 (4.3751)	102.3 (4.031)	
10	132.4	15.211	100.01	3.9381	122.24 (4.8131)	113.4 (4.471)	
11	143.5	15.651	111.13	4.3751	133.35 (5.2501)	124.6 (4.901)	
12	154.6	16.091	122.24	4.8131	144.46 (5.6881)	135.7 (5.341)	
13	165.7	16.531	133.35	5.2501	155.58 (6.1251)	146.8 (5.781)	
14	176.8	16.961	144.46	5.6881	166.69 (6.5631)	157.9 (6.221)	
15	188.0	17.401	155.58	6.1251	177.80 (7.0001)	169.0 (6.651)	
16	199.1	17.841	166.69	6.5631	188.91 (7.4381)	180.1 (7.091)	
17	210.2	18.281	177.80	7.0001	200.03 (7.8751)	191.2 (7.531)	
18	221.3	18.711	188.91	7.4381	211.14 (8.3131)	202.3 (7.971)	
19	232.4	19.151	200.03	7.8751	222.25 (8.7501)	213.5 (8.401)	
20	243.5	19.591	211.14	8.3131	233.36 (9.1881)	224.6 (8.841)	

ITEM	QTY.	DESCRIPTION	MATERIAL	FINISH
4	XX	SCREW, #6-32, PHIL-SLOT, SQ. WASHER	BRASS	NICKEL PLATE
3	XX	TERMINAL, FAST TAB	BRASS	TIN PLATE
2	1	COVER, HINGED	THERMOPLASTIC	BLACK
1	1	INSULATOR, SR, CS, NO MTG.	THERMOPLASTIC	BLACK

EC NO. RELEASED DRAWN: CLY CH: K1 APPR:	DESCRIPTION MAJOR CRITICAL SPC S	GENERAL TOLERANCES: (UNLESS SPECIFIED)		SCALE 1.5:1	DESIGN UNITS <input type="checkbox"/> mm <input checked="" type="checkbox"/> INCH	THIRD ANGLE PROJECTION	DIMENSIONS: <input checked="" type="checkbox"/> mm <input type="checkbox"/> INCH <input type="checkbox"/> mm <input type="checkbox"/> ONLY	PROJECT NO. - - SHT - REV -
		4 PLACES mm ±.0015 INCH ±.0015 3 PLACES mm ±.038 INCH ±.005 2 PLACES mm ±.13 INCH ±.01 1 PLACE mm ±.3 INCH ±.01		DRAWN BY & DATE C. YORK 02-16-05	TITLE: SR BTS, CS, INSUL. FAST TAB, ASSY W/HINGED COVER			
		ANGULAR: ±2°		CHECKED BY & DATE	APPROVED BY & DATE			
		DRAFT WHERE APPLICABLE MUST REMAIN WITHIN DIMENSIONS		CAD FILENAME 73R9XX-H-49-50	MATERIAL NO. SEE CHART	DRAWING NO. SD-38739-012	SHEET NO. 1 OF 1	SIZE B

THIS DRAWING CONTAINS INFORMATION THAT IS PROPRIETARY TO MOLEX INCORPORATED AND SHOULD NOT BE USED WITHOUT WRITTEN PERMISSION.

F
E
D
C
B
A

F
E
D
C
B
A

10 9 8 7 6 5 4 3 2 1