



PROGRAMMABLE FLEXP LP/S CLOCK FOR INTEL BASED SYSTEMS

**IDTCV193
ADVANCE
INFORMATION**

FEATURES:

- Compliant with Intel CK505 Gen II spec
- One high precision PLL for CPU, SSC and N programming
- One high precision PLL for SRC, SSC and N programming
- One high precision PLL for SATA/PCI, and SSC
- One high precision PLL for 96MHz/48MHz
- Push-pull IOs for differential outputs
- Support spread spectrum modulation, -0.5 down spread and others
- Support SMBus block read/write, byte read/write
- Available in TSSOP package

OUTPUTS:

- 2 - 0.7V differential CPU CLK pair
- 10 - 0.7V differential SRC CLK pair
- 1 - CPU_ITP/SRC differential clock pair
- 1 - SRC0/DOT96 differential clock pair
- 6 - PCI, 33.3MHz
- 1 - 48MHz
- 1 - REF
- 1 - SATA

KEY FEATURES

- Direct CPU and SRC clock frequency programming—write the Hex number into Byte [16:18], 1MHz stepping.
- Linear and smooth transition for the CPU and SRC frequency programming.
- SATA PLL source hardware select latch pin, PLL2 or PLL4.
- Internal serial resistor hardware enable latch pin.
- WOL 25MHz support.

KEY SPECIFICATIONS:

- CPU/SRC CLK cycle to cycle jitter < 85ps
- PCI CLK cycle to cycle jitter < 500ps
- All SRC, SRC[0:11] phase noise < 3.10s RMS, PCIE Gen II phase noise requirement.
- SRC3, 4, 6, 7, designated PCIE Gen II outputs, nominal interpair skew = 0 ps

FUNCTIONAL BLOCK DIAGRAM

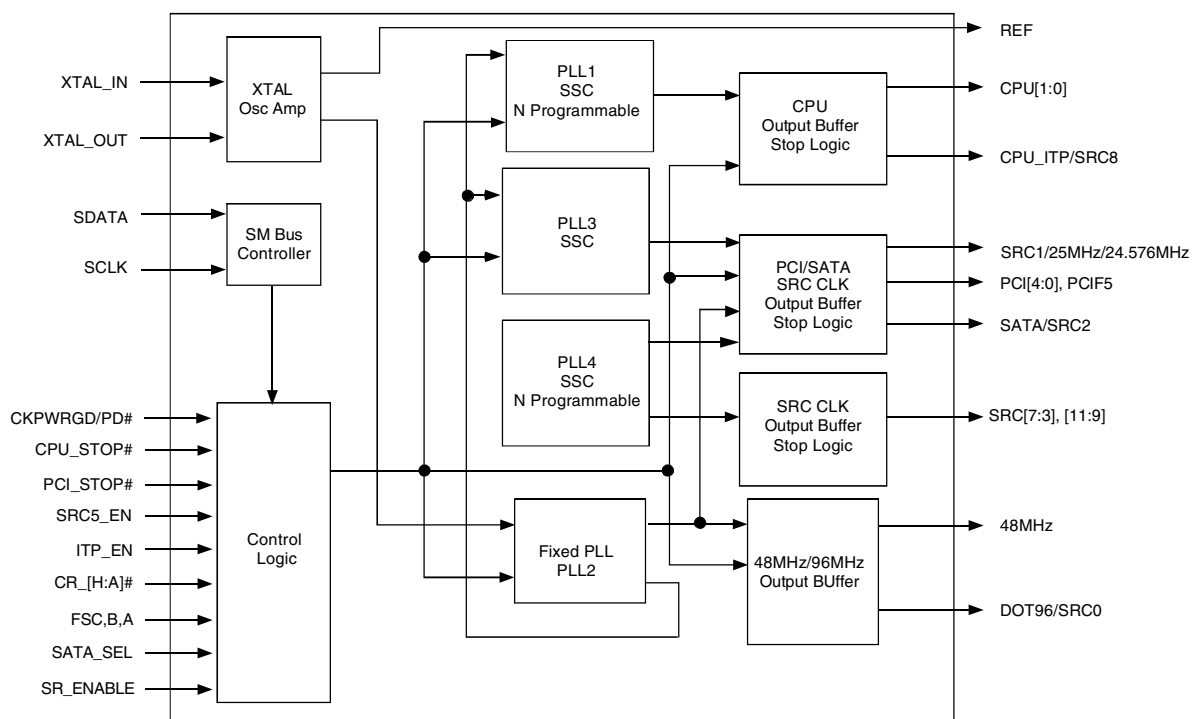

The IDT logo is a registered trademark of Integrated Device Technology, Inc.

COMMERCIAL TEMPERATURE RANGE

IDT CONFIDENTIAL

APRIL 8, 2009

PIN CONFIGURATION

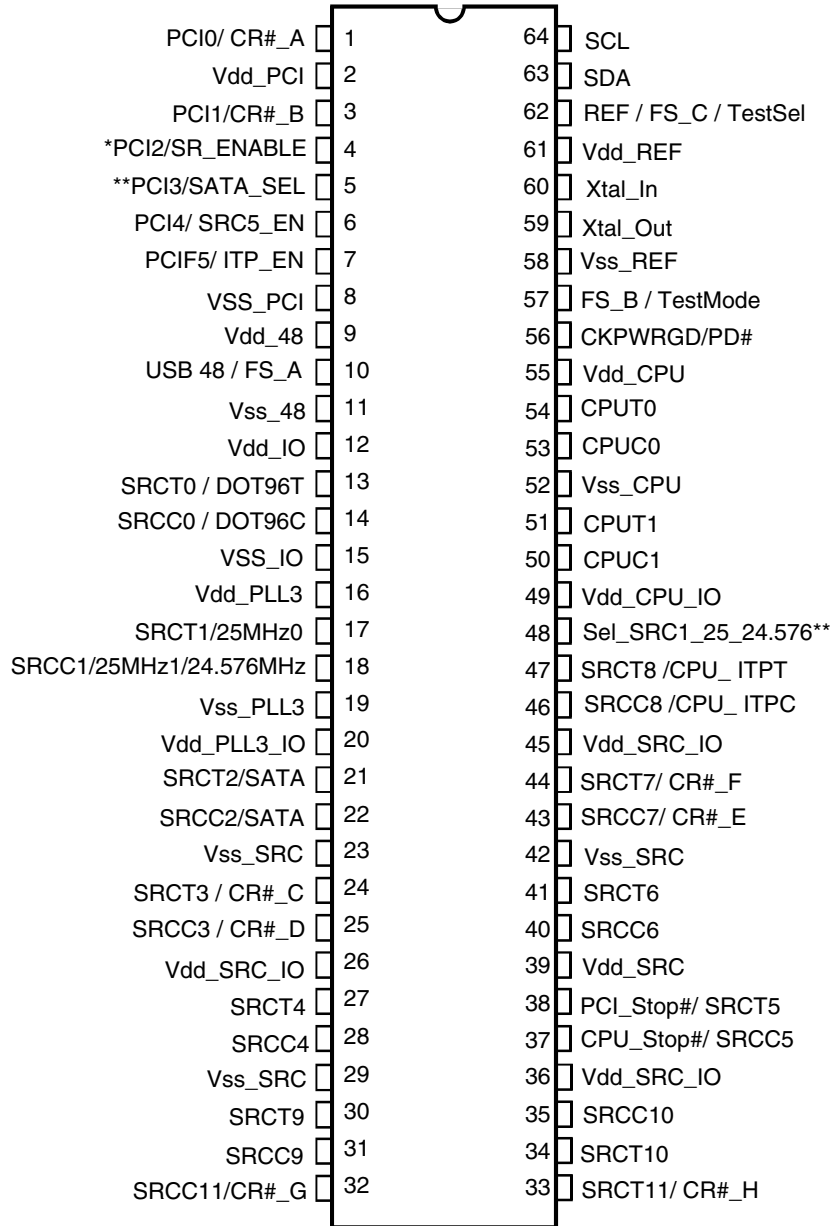

* Internal 100k pull high

** Internal 100k pull low

TSSOP
TOP VIEW

PIN DESCRIPTION

| Pin # | Name | Type | Description |
|-------|-------------------------|------|---|
| 1 | PCI0/CR#_A | I/O | 33.33MHz. SRC0, 2 Differential clock output enable, control SRC0 and SRC2, 0 = enable. Mode is selected by SMBus control register. Default is PCI clock mode. |
| 2 | V _{DD_PCI} | PWR | 3.3V |
| 3 | PCI1/CR#_B | I/O | 33.33MHz. SRC1, 4 Differential clock output enable, control SRC1 and SRC4, 0 = enable. Mode is selected by SMBus control register. Default is PCI clock mode. |
| 4 | PCI2/SRC_ENABLE | I/O | Power on latch, high, internal 33 ohm resistor enabled. Low, disabled. Afterward 33.33MH |
| 5 | PCI3/SATA_SEL | OUT | Power on Latch, high, SATA from PLL2. Low, SATA from PLL4 (as SRC clock). Afterward, 33.33MHz |
| 6 | PCI4/SRC5_EN | I/O | 33.33MHz. Pin 37, 38 mode selection. Power on latch, HIGH = SRC5, LOW = CPU and PCI Stop#. |
| 7 | PCIF5/ITP_EN | I/O | 33.33MHz. Pin 46, 47 mode selection. Power on latch, HIGH = CPU_ITP, LOW = SRC8. |
| 8 | V _{SS_PCI} | GND | GND |
| 9 | V _{DD_48} | PWR | 3.3V |
| 10 | USB 48/FS_A | I/O | 48MHz, frequency select, power on latch |
| 11 | V _{SS_48} | GND | GND |
| 12 | V _{DD_IO} | PWR | 1.05 ~ 3.3V |
| 13 | SRCT0/DOT96T | OUT | Differential output clock. SRC or DOT96. Mode selected by SMBus control register, default is SRC0. |
| 14 | SRCC0/DOT96C | OUT | Differential output clock. SRC or DOT96. Mode selected by SMBus control register, default is SRC0. |
| 15 | V _{SS_IO} | GND | GND |
| 16 | V _{DD_PLL3} | PWR | 3.3V |
| 17 | SRCT1/25MHz | OUT | SRC or 25MHz, mode selected by pin 48, Sel_SRC1_25_24.576 |
| 18 | SRCC1/25MHz1/24.576MHz | OUT | SRC or 25MHz or 24.576MHz, mode selected by pin 48, Sel_SRC1_25_24.576 |
| 19 | V _{SS_PLL3} | GND | GND |
| 20 | V _{DD_PLL3_IO} | PWR | 1.05 ~ 3.3V |
| 21 | SATAT/SRCT2 | OUT | Differential output clock |
| 22 | SATAC/SRCC2 | OUT | Differential output clock |
| 23 | V _{SS_SRC} | GND | GND |
| 24 | SRCT3/CR#_C | I/O | SRC clock. SRC differential clock output enable, control SRC0 and SRC2, 0 = enable. Mode selected by SMBus control register. Default is SRC3. |
| 25 | SRCC3/CR#_D | I/O | SRC clock. SRC differential clock output enable, control SRC1 and SRC4, 0 = enable. Mode selected by SMBus control register. Default is SRC3. |
| 26 | V _{DD_SRC_IO} | PWR | 1.05 ~ 3.3V |
| 27 | SRCT4 | OUT | Differential output clock |
| 28 | SRCC4 | OUT | Differential output clock |
| 29 | V _{SS_SRC} | GND | GND |
| 30 | SRCT9 | OUT | Differential output clock |
| 31 | SRCC9 | OUT | Differential output clock |
| 32 | SRCC11/CR#_G | I/O | SRC clock. SRC differential clock output enable, control SRC9, 0 = enable. Mode selected by SMBus control register. Default is SRC11. |
| 33 | SRCT11/CR#_H | I/O | SRC clock. SRC differential clock output enable, control SRC10, 0 = enable. Mode selected by SMBus control register. Default is SRC11. |
| 34 | SRCT10 | OUT | Differential output clock |
| 35 | SRCC10 | OUT | Differential output clock |
| 36 | V _{DD_SRC_IO} | PWR | 1.05 ~ 3.3V |
| 37 | CPU_Stop#/SRCC5 | I/O | CPU stop, LOW = stop. SRC clock. Mode selected by pin6, SRC5_EN. |
| 38 | PCI_Stop#/SRCT5 | I/O | PCI stop, LOW = stop. SRC clock. Mode selected by pin6, SRC5_EN. |
| 39 | V _{DD_SRC} | PWR | 3.3V |
| 40 | SRCC6 | OUT | Differential output clock |
| 41 | SRCT6 | OUT | Differential output clock |
| 42 | V _{SS_SRC} | GND | GND |

PIN DESCRIPTION, CONTINUED

| Pin # | Name | Type | Description |
|-------|--------------------|------|--|
| 43 | SRCC7/CR#_E | I/O | SRC clock. SRC differential clock output enable, control SRC6, 0 = enable. Mode selected by SMBus control register. Default is SRC7. |
| 44 | SRCT7/CR#_F | I/O | SRC clock. SRC differential clock output enable, control SRC8, 0 = enable. Mode selected by SMBus control register. Default is SRC7. |
| 45 | VDD_SRC_IO | PWR | 1.05 ~ 3.3V |
| 46 | SRCC8/CPU_ ITPC | OUT | SRC clock. CPU clock. Mode selected by pin7. |
| 47 | SRCT8/CPU_ IPTPT | OUT | SRC clock. CPU clock. Mode selected by pin7. |
| 48 | Sel_SRC1_25_24.576 | OUT | Power on latch, Select pin 17, 18 Mode, see pin 48 Function Table. |
| 49 | VDD_CPU_IO | PWR | 1.05 ~ 3.3V |
| 50 | CPUC1 | OUT | Differential output clock |
| 51 | CPUT1 | OUT | Differential output clock |
| 52 | VSS_CPU | GND | GND |
| 53 | CPUC0 | OUT | Differential output clock |
| 54 | CPUT0 | OUT | Differential output clock |
| 55 | VDD_CPU | PWR | 3.3V |
| 56 | CKPWRGD/PD# | IN | CKPWRGD power good, active LOW, used to latch FSA,B,C, ITP_EN, TME, and SRC5_EN, active HIGH. After, becomes power down, LOW active. |
| 57 | FS_B/TestMode | IN | Frequency Select at CKPWRGD assertion. Test Mode selection, see TEST_MODE selection table.q |
| 58 | VSS_REF | GND | GND |
| 59 | XTAL_OUT | OUT | XTAL out |
| 60 | XTAL_IN | IN | XTAL in |
| 61 | VDD_REF | PWR | 3.3V |
| 62 | REF/FS_C/TestSel | I/O | 14.318MHz. Frequency Select at CKPWRGD assertion. Selects test mode if pulled above 2V at CKPWRGD assertion. |
| 63 | SDA | I/O | SMBus data |
| 64 | SCL | IN | SMBus clock |

TEST MODE SELECTION⁽¹⁾

If TEST_SEL sampled above 2V at CKPWRGD active LOW

| Test_Mode | CPU | SRC | PCI/F | REF | DOT_96/DOT_SSC | USB |
|-----------|-------|-------|-------|------|----------------|-------|
| 1 | REF/N | REF/N | REF/N | REF | REF/N | REF/N |
| 0 | Hi-Z | Hi-Z | Hi-Z | Hi-Z | Hi-Z | Hi-Z |

NOTE:

1. Once test clock operation has been invoked, TEST_MODE pin will select between the Hi-Z and REF/N, with V_{IH_FS} and V_{IL_FS} thresholds.

FREQUENCY SELECTION

| FSC, B, A | CPU | SRC[7:0] | PCI | USB | DOT | REF |
|-----------|---------|----------|------|-----|-----|--------|
| 101 | 100 | 100 | 33.3 | 48 | 96 | 14.318 |
| 001 | 133 | 100 | 33.3 | 48 | 96 | 14.318 |
| 011 | 166 | 100 | 33.3 | 48 | 96 | 14.318 |
| 010 | 200 | 100 | 33.3 | 48 | 96 | 14.318 |
| 000 | 266 | 100 | 33.3 | 48 | 96 | 14.318 |
| 100 | 333 | 100 | 33.3 | 48 | 96 | 14.318 |
| 110 | 400 | 100 | 33.3 | 48 | 96 | 14.318 |
| 111 | Reserve | 100 | 33.3 | 48 | 96 | 14.318 |

SEL_SRC1_25_24.576 (PIN 48) VOLTAGE DECODING TABLE

| state | Min | Typ | Max |
|-------|------|-------|------|
| Low | 0V | 0.55V | 0.9V |
| Mid | 1.3V | 1.65V | 2V |
| High | 2.4V | 2.75V | VDD |

SR_ENABLE TABLE

| SR_ENABLE | |
|-------------|---|
| 0 | Need external 33 ohm serial resistor, Byte19 bit7 = 0 |
| 1 (default) | Enable 33 ohm internal serial resistor, Byte19 bit7 = 1 |

SEL_SRC1_25_24.576 FUNCTION TABLE

| Sel_SRC1_25_24.576 (pin48) | CPU | PCI | Pin 17 | Pin 18 | SRC | 48/96 |
|----------------------------|------|------|----------------------|-------------------------|-----------|-------------|
| Low | PLL1 | PLL4 | 25MHz, PLL3 (SS off) | 25MHz PLL3 (SS off) | PLL4 down | PLL2, fixed |
| Mid | PLL1 | PLL4 | SRCT1 | SRCC1 | PLL4 down | PLL2, fixed |
| High | PLL1 | PLL4 | 25MHz PLL2 | 24.576MHz PLL3 (SS off) | PLL4 down | PLL2, fixed |

SATA_SEL TABLE

| SATA_SEL | SRC2/SATA |
|----------|---------------------|
| 0 | PLL4 (SRC PLL, SSC) |
| 1 | PLL2 (48/96 PLL) |

DEVICE ID TABLE

| ID3, ID2, ID1, ID0 | | Comments |
|--------------------|--------------------|---------------------------|
| 0000 | CK505 56 pin TSSOP | CK505 YC |
| 0001 | CK505 64 pin TSSOP | CK505 YC |
| 0010 | 48 pin QFN | CK505 YC |
| 0011 | 56 pin QFN | CK505 YC |
| 0100 | 64 pin QFN | CK505 YC |
| 0101 | 72 pin QFN | CK505 YC |
| 0110 | 48 pin SSOP | CK505 YC |
| 0111 | 56 pin SSOP | CK505 YC |
| 1000 | Reserved | CK505 Derivative (non YC) |
| 1001 | Reserved | |
| 1010 | Reserved | |
| 1011 | Reserved | |
| 1100 | Reserved | |
| 1101 | Reserved | |
| 1110 | Reserved | |
| 1111 | Reserved | |

IO_VOUT [2:0] TABLE

| | |
|-----|------|
| 000 | 0.3V |
| 001 | 0.4V |
| 010 | 0.5V |
| 011 | 0.6V |
| 100 | 0.7V |
| 101 | 0.8V |
| 110 | 0.9V |
| 111 | 1V |

ABSOLUTE MAXIMUM RATINGS⁽¹⁾

| Symbol | Description | Min | Max | Unit |
|----------|--|-----------|------|------|
| VDDA | 3.3V Core Supply Voltage | | 4.6 | V |
| VDD | 3.3V Logic Input Supply Voltage | GND - 0.5 | 4.6 | V |
| TSTG | Storage Temperature | -65 | +150 | °C |
| TAMBIENT | Ambient Operating Temperature | 0 | +70 | °C |
| TCASE | Case Temperature | | +115 | °C |
| ESD Prot | Input ESD Protection Human Body Model | 2000 | | V |

NOTE:

- Stresses greater than those listed under ABSOLUTE MAXIMUM RATINGS may cause permanent damage to the device. This is a stress rating only and functional operation of the device at these or any other conditions above those indicated in the operational sections of this specification is not implied. Exposure to absolute maximum rating conditions for extended periods may affect reliability.

SM PROTOCOL

INDEX BLOCK WRITE PROTOCOL

| Bit | # of bits | From | Description |
|-------|-----------|--------|--------------------------------------|
| 1 | 1 | Master | Start |
| 2-9 | 8 | Master | D2h |
| 10 | 1 | Slave | Ack (Acknowledge) |
| 11-18 | 8 | Master | Register offset byte (starting byte) |
| 19 | 1 | Slave | Ack (Acknowledge) |
| 20-27 | 8 | Master | Byte count, N (0 is not valid) |
| 28 | 1 | Slave | Ack (Acknowledge) |
| 29-36 | 8 | Master | first data byte (Offset data byte) |
| 37 | 1 | Slave | Ack (Acknowledge) |
| 38-45 | 8 | Master | 2nd data byte |
| 46 | 1 | Slave | Ack (Acknowledge) |
| | | | : |
| | | Master | Nth data byte |
| | | Slave | Acknowledge |
| | | Master | Stop |

INDEX BLOCK READ PROTOCOL

Master can stop reading any time by issuing the stop bit without waiting until Nth byte (byte count bit 30-37).

| Bit | # of bits | From | Description |
|-------|-----------|--------|--|
| 1 | 1 | Master | Start |
| 2-9 | 8 | Master | D2h |
| 10 | 1 | Slave | Ack (Acknowledge) |
| 11-18 | 8 | Master | Register offset byte (starting byte) |
| 19 | 1 | Slave | Ack (Acknowledge) |
| 20 | 1 | Master | Repeated Start |
| 21-28 | 8 | Master | D3h |
| 29 | 1 | Slave | Ack (Acknowledge) |
| 30-37 | 8 | Slave | Byte count, N (block read back of N bytes) |
| 38 | 1 | Master | Ack (Acknowledge) |
| 39-46 | 8 | Slave | first data byte (Offset data byte) |
| 47 | 1 | Master | Ack (Acknowledge) |
| 48-55 | 8 | Slave | 2nd data byte |
| | | | Ack (Acknowledge) |
| | | | : |
| | | Master | Ack (Acknowledge) |
| | | Slave | Nth data byte |
| | | | Not acknowledge |
| | | Master | Stop |

N-PROGRAMMING PROCEDURE

- Byte 16 bit 3 has to be "1". This bit will decode the power on latched value of pins 4, 5 (see CFG table 1).
- User writes the desired CPU frequency in HEX form into CPUN [8:0], Byte 16, 17.
- User writes the desired SRC frequency in HEX form into PN [7:0], Byte 18.

CONTROL REGISTERS

BYTE 0

| Bit | Output(s) Affected | Description/Function | 0 | 1 | Type | Power On |
|-----|--------------------|--|--|------------------------|------|------------------|
| 7 | FSC | Latched FSC | | | R | Latched Value |
| 6 | FSB | Latched FSB | | | R | Latched Value |
| 5 | FSA | Latched FSA | | | R | Latched Value |
| 4 | iAMT_EN | iAMT Mode | Legacy Mode | Enabled | RW | HW M1 setting(1) |
| 3 | Reserved | | | | RW | 0 |
| 2 | Reserved | | | | RW | 0 |
| 1 | SRC2/SATA source | | PLL4 | PLL2 | RW | SATA_SEL latch |
| 0 | PD_Restore | SMBUS control registers setting after the power down | Power on default, With some exceptions | Save register contents | RW | 1 |

NOTES:

1. Sticky 1, can only be reset by power off.

BYTE 1

| Bit | Output(s) Affected | Description/Function | 0 | 1 | Type | Power On |
|-----|--------------------|----------------------|-------------|---------------|------|----------|
| 7 | SRC0_sel | Pin13/14 mode select | SRC0 | DOT96 | RW | 0 |
| 6 | PLL1_SSC_DC | SSC mode selection | Down spread | Center spread | RW | 1 |
| 5 | PLL4_SSC_DC | SSC mode selection | Down spread | Center spread | RW | 0 |
| 4 | Reserved | | | | RW | 0 |
| 3 | Reserved | | | | RW | 0 |
| 2 | 25MHz_0 | PD# free run control | Disabled | Free run | RW | 1 |
| 1 | 25MHz_1 | PD# free run control | Disabled | Free run | RW | 1 |
| 0 | PCI | | PLL2 | PLL4 | RW | 1 |

BYTE 2

| Bit | Output(s) Affected | Description/Function | 0 | 1 | Type | Power On |
|-----|--------------------|----------------------|----------|--------|------|----------|
| 7 | REF | Output Enable | Tristate | Enable | RW | 1 |
| 6 | USB_48 | Output Enable | Tristate | Enable | RW | 1 |
| 5 | PCIF5 | Output Enable | Tristate | Enable | RW | 1 |
| 4 | PCI4 | Output Enable | Tristate | Enable | RW | 1 |
| 3 | PCI3 | Output Enable | Tristate | Enable | RW | 1 |
| 2 | PCI2 | Output Enable | Tristate | Enable | RW | 1 |
| 1 | PCI1 | Output Enable | Tristate | Enable | RW | 1 |
| 0 | PCI0 | Output Enable | Tristate | Enable | RW | 1 |

BYTE 3

| Bit | Output(s) Affected | Description/Function | 0 | 1 | Type | Power On |
|-----|--------------------|----------------------|----------|---------|------|----------|
| 7 | SRC11 | Output Enable | Tristate | Enabled | RW | 1 |
| 6 | SRC10 | Output Enable | Tristate | Enabled | RW | 1 |
| 5 | SRC9 | Output Enable | Tristate | Enabled | RW | 1 |
| 4 | SRC8/ITP | Output Enable | Tristate | Enabled | RW | 1 |
| 3 | SRC7 | Output Enable | Tristate | Enabled | RW | 1 |
| 2 | SRC6 | Output Enable | Tristate | Enabled | RW | 1 |
| 1 | SRC5 | Output Enable | Tristate | Enabled | RW | 1 |
| 0 | SRC4 | Output Enable | Tristate | Enabled | RW | 1 |

BYTE 4

| Bit | Output(s) Affected | Description/Function | 0 | 1 | Type | Power On |
|-----|--------------------|----------------------|----------|---------|------|----------|
| 7 | SRC3 | Output Enable | Disabled | Enabled | RW | 1 |
| 6 | SATA/SRC2 | Output Enable | Disabled | Enabled | RW | 1 |
| 5 | SRC1 | Output Enable | Disabled | Enabled | RW | 1 |
| 4 | SRC0/DOT96 | Output Enable | Disabled | Enabled | RW | 1 |
| 3 | CPU1 | Output Enable | Disabled | Enabled | RW | 1 |
| 2 | CPU0 | Output Enable | Disabled | Enabled | RW | 1 |
| 1 | PLL1_SSC_ON | SSC Enable | Disabled | Enabled | RW | 1 |
| 0 | PLL4_SSC_ON | SSC Enable | Disabled | Enabled | RW | 1 |

BYTE 5

| Bit | Output(s) Affected | Description/Function | 0 | 1 | Type | Power On |
|-----|--------------------|-------------------------|---------------------|------------|------|----------|
| 7 | CR#_A | Pin1 mode selection | PCI0 mode | CR#_A mode | RW | 0 |
| 6 | CR#_A control | CR#_A control selection | SRC0 | SRC2 | RW | 0 |
| 5 | CR#_B | Pin3 mode selection | PCI1 mode | CR#_B mode | RW | 0 |
| 4 | CR#_B control | CR#_B control selection | SRC1 ⁽¹⁾ | SRC4 | RW | 0 |
| 3 | CR#_C | Pin24 mode selection | SRCT3 mode | CR#_C mode | RW | 0 |
| 2 | CR#_C control | CR#_C control selection | SRC0 | SRC2 | RW | 0 |
| 1 | CR#_D | Pin25 mode selection | SRCC3 mode | CR#_D mode | RW | 0 |
| 0 | CR#_D control | CR#_D control selection | SRC1 | SRC4 | RW | 0 |

NOTE:

1. Only when SRC1 is SRC Clock.

BYTE 6⁽¹⁾

| Bit | Output(s) Affected | Description/Function | 0 | 1 | Type | Power On |
|-----|--------------------|-------------------------------------|--------------|----------------------------|------|----------|
| 7 | CR#_E | Pin43 mode selection, control SRC6 | SRCC7 mode | CR#_E mode, Control SRC 6 | RW | 0 |
| 6 | CR#_F | Pin44 mode selection, control SRC8 | SRCT7 mode | CR#_F mode, Control SRC 8 | RW | 0 |
| 5 | CR#_G | Pin32 mode selection, control SRC9 | SRCC11 mode | CR#_G mode, Control SRC 9 | RW | 0 |
| 4 | CR#_H | Pin33 mode selection, control SRC10 | SRCT11 mode | CR#_H mode, Control SRC 10 | RW | 0 |
| 3 | Reserved | | | | RW | 0 |
| 2 | Reserved | | | | RW | 0 |
| 1 | Reserved | | | | RW | 0 |
| 0 | SRC_STP_CRTL | If set, SRCs stop with PCI_STOP# | Free running | Stoppable | RW | 0 |

NOTE:

1. STOP - CPUT and SRCT stay high, CPUC and SRCC stay low.

BYTE 7

| Bit | Output(s) Affected | Description/Function | 0 | 1 | Type | Power On |
|-----|--------------------|----------------------|---|---|------|----------|
| 7 | | Revision ID | | | | 0 |
| 6 | | Revision ID | | | | 0 |
| 5 | | Revision ID | | | | 0 |
| 4 | | Revision ID | | | | 0 |
| 3 | | Vendor ID | | | | 0 |
| 2 | | Vendor ID | | | | 1 |
| 1 | | Vendor ID | | | | 0 |
| 0 | | Vendor ID | | | | 1 |

BYTE 8

| Bit | Output(s) affected | Description/ Function | 0 | 1 | Type | Power On |
|-----|--------------------|---|----------|---------|------|----------|
| 7 | Device_ID3 | See device ID table | | | R | |
| 6 | Device_ID2 | | | | R | |
| 5 | Device_ID1 | | | | R | |
| 4 | Device_ID0 | | | | R | |
| 3 | | | | | RW | 0 |
| 2 | | | | | RW | 0 |
| 1 | Pin 17_SE_OE | Output enable (Cannot be reset by PD Restore) | Disabled | Enabled | RW | 1 |
| 0 | Pin 18_SE_OE | Output enable (Can not be reset by PD Restore) | Disabled | Enabled | RW | 1 |

BYTE 9

| Bit | Output(s) Affected | Description/ Function | 0 | 1 | Type | Power On |
|-----|----------------------|---------------------------------|------------------|--------------------------------------|------|----------|
| 7 | PCIF5 with PCI_STOP# | Free running | Free running | stoppable | RW | 0 |
| 6 | Reserved | | | | | |
| 5 | REF Drive Strength | Strength control | 1x | 2x | RW | 1 |
| 4 | | Only valid when Byte9 bit3 is 1 | Hi-Z | REF/N mode | RW | 0 |
| 3 | | Test Mode entry control | Normal operation | Test mode, controlled by byte9 bit 4 | RW | 0 |
| 2 | IO_VOUT2 | | | | RW | 1 |
| 1 | IO_VOUT1 | Programmable IO_Vout voltage | | | RW | 0 |
| 0 | IO_VOUT0 | | | | RW | 1 |

BYTE 10

| Bit | Output(s) affected | Description/ Function | 0 | 1 | Type | Power On |
|-----|--------------------|------------------------|--------------|--------------|------|----------------------|
| 7 | | SRC5_EN_Strap | | | R | The latch of SRC5_EN |
| 6 | PLL3 | PLL3 enable | PLL3 pwr dwn | Pwr up | RW | 1 |
| 5 | PLL2 | PLL2 enable | PLL2 pwr dwn | Pwr up | RW | 1 |
| 4 | SRC_DIV | SRC divider disable | disable | enable | RW | 1 |
| 3 | PCI_DIV | PCI divider disable | disable | enable | RW | 1 |
| 2 | CPU_DIV | CPU divider disable | disable | enable | RW | 1 |
| 1 | CPU1 Free run | Controlled by CPU_STP# | Free run | Controllable | RW | 1 |
| 0 | CPU0 Free run | Controlled by CPU_STP# | Free run | Controllable | RW | 1 |

BYTE 11 - RESERVED

| Bit | Output(s) affected | Description/ Function | 0 | 1 | Type | Power On |
|-----|--------------------|---|-------------|------------|------|----------|
| 7 | Reserved | | | | R | |
| 6 | Reserved | | | | R | |
| 5 | Reserved | | | | RW | 0 |
| 4 | Reserved | | | | RW | 1 |
| 3 | CPU_ITP_AMT_EN | M1 mode CLK enable at M1 mode Only if ITP_EN = 1 | disable | enable | RW | 0 |
| 2 | CPU1_AMT_EN | M1 mode CLK enable at M1 mode | disable | enable | RW | 1 |
| 1 | PCI GEN II | GEN II compliance | None GEN II | GEN II | R | 1 |
| 0 | CPU_ITP_STOP_EN | Free run control | Free run | Controlled | RW | 1 |

BYTE 12 - BYTE COUNT - DEFAULT 0x13H

BYTE 13

| Bit | Output(s) Affected | Description/ Function | 0 | 1 | Type | Power On |
|-----|--------------------|-----------------------|----|----|------|----------|
| 7 | 48M | Strength control | 1x | 2x | RW | 1 |
| 6 | REF | Strength control | 1x | 2x | RW | 0 |
| 5 | PCIF5 | Strength control | 1x | 2x | RW | 1 |
| 4 | PCI4 | Strength control | 1x | 2x | RW | 1 |
| 3 | PCI3 | Strength control | 1x | 2x | RW | 1 |
| 2 | PCI2 | Strength control | 1x | 2x | RW | 1 |
| 1 | PCI1 | Strength control | 1x | 2x | RW | 1 |
| 0 | PCI0 | Strength control | 1x | 2x | RW | 1 |

BYTE 14 RESERVED

BYTE 15, WATCH DOG⁽¹⁾

| Bit | Output(s) Affected | Description / Function | 0 | 1 | Type | Power On |
|-----|-----------------------------|--|-----------------|---------------------|------|----------|
| 7 | Watch Dog Enable | Watch Dog Alarm Enable | Disabled | Enabled | RW | 0 |
| 6 | Watch Dog Select | Watch Dog Hard/Soft Alarm Select | Hard Alarm Only | Hard and Soft Alarm | RW | 0 |
| 5 | Watch Dog Hard Alarm Status | Watch Dog Hard Alarm Status | Normal | Alarm | R | |
| 4 | Watch Dog Soft Alarm Status | Watch Dog Soft Alarm Status | Normal | Alarm | R | |
| 3 | Watch Dog control | Watch Dog Time Base Control | 290ms base | 1160ms base | RW | 0 |
| 2 | WD_1_Timer 2 | WatchDog_1_Alarm Timer Default is 7*290ms | | | RW | 1 |
| 1 | WD_1_Timer 1 | | | | RW | 1 |
| 0 | WD_1_Timer 0 | | | | RW | 1 |

NOTE:

1. Hard Alarm switch to HW FS frequency.

BYTE 16

| Bit | Output(s) Affected | Description / Function | 0 | 1 | Type | Power On |
|-----|----------------------|---|----------|--|------|----------|
| 7 | WDEAPD | Set Byte15 bit7 = 1 after Power Down to enable the watch dog after the power down | Disabled | Enabled | RW | 0 |
| 6 | Reserved | | | | RW | 0 |
| 5 | Reserved | | | | RW | 0 |
| 4 | Test_scl | On chip test mode enable | normal | SCLK=1, clk outputs = 1 SCLK=0, clk outputs=0 | RW | 0 |
| 3 | N programming Enable | | Disabled | Enabled | RW | 0 |
| 2 | Reserved | | | | RW | 0 |
| 1 | Reserved | | | | RW | 0 |
| 0 | CPUN8 | | | | RW | FS latch |

BYTE 17 (PLL1)

| Bit | Output(s) Affected | Description / Function | 0 | 1 | Type | Power On |
|-----|--------------------|--|---|---|------|----------|
| 7 | CPUN7 | CPU clock frequency = CPUN [8:0] (Hex) | | | RW | FS latch |
| 6 | CPUN6 | | | | RW | |
| 5 | CPUN5 | | | | RW | |
| 4 | CPUN4 | | | | RW | |
| 3 | CPUN3 | | | | RW | |
| 2 | CPUN2 | | | | RW | |
| 1 | CPUN1 | | | | RW | |
| 0 | CPUN0 | | | | RW | |

BYTE 18 (PLL4)

| Bit | Output(s) Affected | Description / Function | 0 | 1 | Type | Power On |
|-----|--------------------|---|---|---|------|----------|
| 7 | PN 7 | SRC clock frequency = PNC [7:0] (Hex) | | | RW | 100MHz |
| 6 | PN 6 | | | | RW | |
| 5 | PN 5 | | | | RW | |
| 4 | PN 4 | | | | RW | |
| 3 | PN 3 | | | | RW | |
| 2 | PN 2 | | | | RW | |
| 1 | PN 1 | | | | RW | |
| 0 | PN 0 | | | | RW | |

BYTE 19 CLOCK SOURCE SELECTION, WRITTEN AFTER STOP BIT

| Bit | Output(s) Affected | Description / Function | 0 | 1 | Type | Power On |
|-----|------------------------|------------------------|-------------------------------------|---|------|-----------------|
| 7 | Output serial resistor | | 0 ohm (External resistor needed) | 33 ohm (No external resistor needed) | RW | SR_ENABLE latch |
| 6 | PLL1 SSC | spread % selection | 0.5% (p-p) | 0.45%(p-p) | RW | 0 |
| 5 | Reserved | | | | RW | 0 |
| 4 | PLL4 SSC | spread % selection | 0.5% (p-p) | 0.45%(p-p) | RW | 0 |
| 3 | Reserved | | | | RW | 0 |
| 2 | Reserved | | | | RW | 0 |
| 1 | Reserved | | | | RW | 0 |
| 0 | Reserved | | | | RW | 0 |

ABSOLUTE MAXIMUM RATINGS

| PARAMETER | SYMBOL | CONDITIONS | MIN | MAX | UNITS | Notes |
|------------------------|-----------------|-------------------------------------|-----------|-----|-------|-------|
| Maximum Supply Voltage | VDDxxx | Supply Voltage | | 4.6 | V | 1,7 |
| Maximum Supply Voltage | VDDxxx_IO | Low-Voltage Differential I/O Supply | | 3.8 | V | 1,7 |
| Maximum Input Voltage | V _{IH} | 3.3V LVCMOS Inputs | | 4.6 | V | 1,7,8 |
| Minimum Input Voltage | V _{IL} | Any Input | GND - 0.5 | | V | 1,7 |
| Storage Temperature | T _s | - | -65 | 150 | °C | 1,7 |
| Input ESD protection | ESD prot | Human Body Model | 2000 | | V | 1,7 |

ELECTRICAL CHARACTERISTICS - INPUT/SUPPLY/COMMON OUTPUT PARAMETERS

| PARAMETER | SYMBOL | CONDITIONS | MIN | MAX | UNITS | Notes |
|--|-------------------------|--|-----------------------|-----------------------|-------|-------|
| Ambient Operating Temp | T _{ambient} | - | 0 | 70 | °C | 1 |
| Supply Voltage | VDDxxx | Supply Voltage | 3.135 | 3.465 | V | 1 |
| Supply Voltage | VDDxxx_IO | Low-Voltage Differential I/O Supply | 1.05 | 3.3 | V | 1 |
| Input High Voltage | V _{IHSE} | Single-ended inputs | 2 | V _{DD} + 0.3 | V | 1 |
| Input Low Voltage | V _{ILSE} | Single-ended inputs | V _{SS} - 0.3 | 0.8 | V | 1 |
| Input Leakage Current | I _{IN} | V _{IN} = V _{DD} , V _{IN} = GND | -5 | 5 | uA | 1 |
| Input Leakage Current | I _{INRES} | Inputs with pull or pull down resistors V _{IN} = V _{DD} , V _{IN} = GND | -200 | 200 | uA | 1 |
| Output High Voltage | V _{OHSE} | Single-ended outputs, I _{OH} = -1mA | 2.4 | | V | 1 |
| Output Low Voltage | V _{OLSE} | Single-ended outputs, I _{OL} = 1 mA | | 0.4 | V | 1 |
| Output High Voltage | V _{OHDF} | Differential Outputs, I _{OH} = TBD mA | 0.7 | 0.9 | V | 1 |
| Output Low Voltage | V _{OLDIF} | Differential Outputs, I _{OL} = TBD mA | | 0.4 | V | 1 |
| Low Threshold Input-High Voltage (Test Mode) | V _{IH_FS_TEST} | 3.3 V +/-5% | 2 | V _{DD} + 0.3 | V | 1 |
| Low Threshold Input-High Voltage | V _{IH_FS} | 3.3 V +/-5% | 0.7 | 1.5 | V | 1 |
| Low Threshold Input-Low Voltage | V _{IL_FS} | 3.3 V +/-5% | V _{SS} - 0.3 | 0.35 | V | 1 |
| Operating Supply Current | I _{DDOP3.3} | Full active, C _L =full load, I _{DD} 3.3V | | 200 | mA | 1 |
| | I _{DD_IO} | Full active, C _L =full load, I _{DD} 3.3 | | 70 | mA | 1 |
| Power Down Current | I _{DD_PD3.3} | 3.3V supply, Power Down Mode | | 5 | mA | 1 |
| | I _{DD_PDIO} | 0.8V IO supply, Power Down Mode | | 0.1 | mA | 1 |
| iAMT Mode Current | I _{DD_iAMT3.3} | 3.3V supply, iAMT Mode | | 80 | mA | 1 |
| | I _{DD_iAMT0.8} | 0.8V IO supply, iAMT Mode | | 10 | mA | 1 |
| Input Frequency | F _i | V _{DD} = 3.3 V | | 15 | MHz | 2 |
| Pin Inductance | L _{pin} | | | 7 | nH | 1 |
| Input Capacitance | C _{IN} | Logic Inputs | 1.5 | 5 | pF | 1 |
| | C _{OUT} | Output pin capacitance | | 6 | pF | 1 |
| | C _{INX} | X1 & X2 pins | | TBD | pF | 1 |
| Spread Spectrum Modulation Frequency | f _{SSMOD} | Triangular Modulation | 30 | 33 | kHz | 1 |

AC ELECTRICAL CHARACTERISTICS - INPUT/COMMON PARAMETERS

| PARAMETER | SYMBOL | CONDITIONS | MIN | MAX | UNITS | Notes |
|-------------------|--------------------|---|-----|-----|-------|-------|
| Clk Stabilization | T _{STAB} | From VDD Power-Up or de-assertion of PD# to 1st clock | | 1.8 | ms | 1 |
| Tdrive_SRC | T _{DRSRC} | SRC output enable after PCI_STOP# de-assertion | | 15 | ns | 1 |
| Tdrive_PD# | T _{DRPD} | Differential output enable after PD# de-assertion | | 300 | us | 1 |
| Tdrive_CPU | T _{DRSRC} | CPU output enable after CPU_STOP# de-assertion | | 10 | ns | 1 |
| Tfall_PD# | T _{FALL} | Fall/rise time of PD#, PCI_STOP# and CPU_STOP# inputs | | 5 | ns | 1 |
| Trise_PD# | T _{RISE} | | | 5 | ns | 1 |

AC ELECTRICAL CHARACTERISTICS - LOW POWER DIFFERENTIAL OUTPUTS

| PARAMETER | SYMBOL | CONDITIONS | MIN | MAX | UNITS | NOTES |
|-----------------------------|-----------------------|--------------------------|------|------|-------|-------|
| Rising Edge Slew Rate | t _{SLR} | Differential Measurement | 2.5 | 8 | V/ns | 1,2 |
| Falling Edge Slew Rate | t _{FLR} | Differential Measurement | 2.5 | 8 | V/ns | 1,2 |
| Slew Rate Variation | t _{SLVAR} | Single-ended Measurement | | 20 | % | 1 |
| Maximum Output Voltage | V _{HIGH} | Includes overshoot | | 1150 | mV | 1 |
| Minimum Output Voltage | V _{LOW} | Includes undershoot | -300 | | mV | 1 |
| Differential Voltage Swing | V _{SWING} | Differential Measurement | 300 | | mV | 1 |
| Crossing Point Voltage | V _{XABS} | Single-ended Measurement | 300 | 550 | mV | 1,3,4 |
| Crossing Point Variation | V _{XABSVAR} | Single-ended Measurement | | 140 | mV | 1,3,5 |
| Duty Cycle | D _{CYC} | Differential Measurement | 45 | 55 | % | 1 |
| CPU Jitter - Cycle to Cycle | CPUJ _{C2C} | Differential Measurement | | 85 | ps | 1 |
| SRC Jitter - Cycle to Cycle | SRCJ _{C2C} | Differential Measurement | | 125 | ps | 1 |
| DOT Jitter - Cycle to Cycle | DOTJ _{C2C} | Differential Measurement | | 250 | ps | 1 |
| CPU[1:0] Skew | CPU _{SKEW10} | Differential Measurement | | 100 | ps | 1 |
| CPU[2_ITP:0] Skew | CPU _{SKEW20} | Differential Measurement | | 150 | ps | 1 |
| SRC[10:0] Skew | SRC _{SKEW} | Differential Measurement | | 250 | ps | 1,10 |

ELECTRICAL CHARACTERISTICS - PCICLK/PCICLK_F

| PARAMETER | SYMBOL | CONDITIONS | MIN | MAX | UNITS | NOTES |
|---------------------------|-----------------------|---------------------------------|-------------|----------|-------|-------|
| Long Accuracy | ppm | see Tperiod min-max values | -300 | 300 | ppm | 1,6 |
| Clock period | T _{period} | 33.33MHz output nominal | 29.99100 | 30.00900 | ns | 6 |
| | | 33.33MHz output spread | | 30.15980 | ns | 6 |
| Absolute min/max period | T _{abs} | 33.33MHz output nominal/spread | 29.49100 | 30.65980 | ns | 6 |
| Output High Voltage | V _{OH} | I _{OH} = -1 mA | 2.4 | | V | 1 |
| Output Low Voltage | V _{OL} | I _{OL} = 1 mA | | 0.4 | V | 1 |
| Output High Current | I _{OH} | V _{OH} @ MIN = 1.0 V | -33 | | mA | 1 |
| | | V _{OH} @ MAX = 3.135 V | | -33 | mA | 1 |
| Output Low Current | I _{OL} | V _{OL} @ MIN = 1.95 V | 30 | | mA | 1 |
| | | V _{OL} @ MAX = 0.4 V | | 38 | mA | 1 |
| Rising Edge Slew Rate | t _{SLR} | Measured from 0.8 to 2.0 V | 1 | 4 | V/ns | 1 |
| Falling Edge Slew Rate | t _{FLR} | Measured from 2.0 to 0.8 V | 1 | 4 | V/ns | 1 |
| Duty Cycle | d _{t1} | V _T = 1.5 V | 45 | 55 | % | 1 |
| Skew | t _{skew} | V _T = 1.5 V | | 250 | ps | 1 |
| Intentional PCI-PCI delay | t _{delay} | V _T = 1.5 V | 200 nominal | | ps | 1,9 |
| Jitter, Cycle to cycle | t _{cycc-cyc} | V _T = 1.5 V | | 500 | ps | 1 |

ELECTRICAL CHARACTERISTICS - USB48MHZ

| PARAMETER | SYMBOL | CONDITIONS | MIN | MAX | UNITS | NOTES |
|-------------------------|----------------------|--|----------|----------|-------|-------|
| Long Accuracy | ppm | see T _{period} min-max values | -100 | 100 | ppm | 1,2 |
| Clock period | T _{period} | 48.00MHz output nominal | 20.83125 | 20.83542 | ns | 2 |
| Absolute min/max period | T _{abs} | 48.00MHz output nominal | 20.48130 | 21.18540 | ns | 2 |
| Output High Voltage | V _{OH} | I _{OH} = -1 mA | 2.4 | | V | 1 |
| Output Low Voltage | V _{OL} | I _{OL} = 1 mA | | 0.4 | V | 1 |
| Output High Current | I _{OH} | V _{OH} @ MIN = 1.0 V | -29 | | mA | 1 |
| | | V _{OH} @ MAX = 3.135 V | | -23 | mA | 1 |
| Output Low Current | I _{OL} | V _{OL} @ MIN = 1.95 V | 29 | | mA | 1 |
| | | V _{OL} @ MAX = 0.4 V | | 27 | mA | 1 |
| Rising Edge Slew Rate | t _{SLR} | Measured from 0.8 to 2.0 V | 1 | 2 | V/ns | 1 |
| Falling Edge Slew Rate | t _{FLR} | Measured from 2.0 to 0.8 V | 1 | 2 | V/ns | 1 |
| Duty Cycle | d _{t1} | V _T = 1.5 V | 45 | 55 | % | 1 |
| Jitter, Cycle to cycle | t _{jyc-cyc} | V _T = 1.5 V | | 350 | ps | 1 |

ELECTRICAL CHARACTERISTICS - SMBUS INTERFACE

| PARAMETER | SYMBOL | CONDITIONS | MIN | MAX | UNITS | Notes |
|---|---------------------|---|-----|------|-------|-------|
| SMBus Voltage | V _{DD} | | 2.7 | 5.5 | V | 1 |
| Low-level Output Voltage | V _{OL} SMB | @ I _{PULLUP} | | 0.4 | V | 1 |
| Current sinking at V _{OL} SMB = 0.4 V | I _{PULLUP} | SMB Data Pin | 4 | | mA | 1 |
| SCLK/SDATA Clock/Data Rise Time | T _{RI2C} | (Max VIL - 0.15) to (Min VIH + 0.15) | | 1000 | ns | 1 |
| SCLK/SDATA Clock/Data Fall Time | T _{FI2C} | (Min VIH + 0.15) to (Max VIL - 0.15) | | 300 | ns | 1 |
| Maximum SMBus Operating Frequency | F _{SMBUS} | Block Mode | | 100 | kHz | 1 |

ELECTRICAL CHARACTERISTICS - REF-14.318MHZ

| PARAMETER | SYMBOL | CONDITIONS | MIN | MAX | UNITS | Notes |
|-------------------------|----------------------|---|---------|----------|-------|-------|
| Long Accuracy | ppm | see T _{period} min-max values | -300 | 300 | ppm | 1,2 |
| Clock period | T _{period} | 14.318MHz output nominal | 69.8203 | 69.8622 | ns | 2 |
| Absolute min/max period | T _{abs} | 14.318MHz output nominal | 69.8203 | 70.86224 | ns | 2 |
| Output High Voltage | V _{OH} | I _{OH} = -1 mA | 2.4 | | V | 1 |
| Output Low Voltage | V _{OL} | I _{OL} = 1 mA | | 0.4 | V | 1 |
| Output High Current | I _{OH} | V _{OH} @MIN = 1.0 V, V _{OH} @MAX = 3.135 V | -33 | -33 | mA | 1 |
| Output Low Current | I _{OL} | V _{OL} @MIN = 1.95 V, V _{OL} @MAX = 0.4 V | 30 | 38 | mA | 1 |
| Rising Edge Slew Rate | t _{SLR} | Measured from 0.8 to 2.0 V | 1 | 4 | V/ns | 1 |
| Falling Edge Slew Rate | t _{FLR} | Measured from 2.0 to 0.8 V | 1 | 4 | V/ns | 1 |
| Duty Cycle | d _{t1} | V _T = 1.5 V | 45 | 55 | % | 1 |
| Jitter | t _{jyc-cyc} | V _T = 1.5 V | | 1000 | ps | 1 |

Notes on Electrical Characteristics:

¹Guaranteed by design and characterization, not 100% tested in production.

²Slew rate measured through V_{swing} centered around differential zero

³V_{xabs} is defined as the voltage where CLK = CLK#

⁴Only applies to the differential rising edge (CLK rising and CLK# falling)

⁵Defined as the total variation of all crossing voltages of CLK rising and CLK# falling. Matching applies to rising edge rate of CLK and falling edge of CLK#. It is measured using a +/-75mV window centered on the average cross point where CLK meets CLK#.

⁶All Long Term Accuracy and Clock Period specifications are guaranteed assuming that REFOUT is at 14.31818MHz

⁷Operation under these conditions is neither implied, nor guaranteed.

⁸Maximum input voltage is not to exceed maximum VDD

⁹See PCI Clock-to-Clock Delay Figure

¹⁰SRC 3,4,6,7, are 0 ps nominal interpair skew

PCI STOP FUNCTIONALITY

| PCI_STOP# | SRC | SRC# | PCI |
|-----------|--------|--------|-------|
| 1 | Normal | Normal | 33MHz |
| 0 | High | Low | Low |

PCI_STOP# ASSERTION (TRANSITION FROM '1' TO '0')

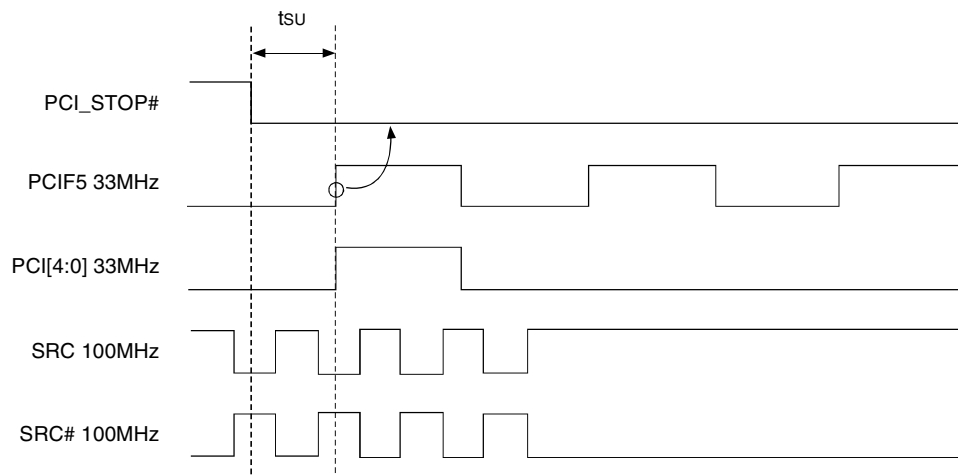

PCI_STOP# - DE-ASSERTION (TRANSITION FROM '0' TO '1')

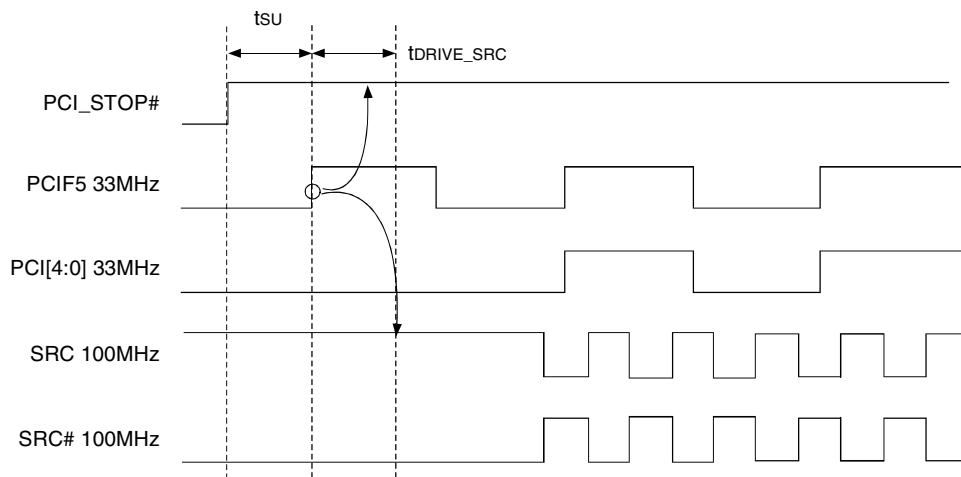

CPU STOP FUNCTIONALITY

The CPU_STOP# signal is an active low input controlling the CPU outputs. This signal can be asserted asynchronously.

| CPU_STOP# | CPU | CPU# |
|-----------|--------|--------|
| 1 | Normal | Normal |
| 0 | High | Low |

CPU_STOP# ASSERTION (TRANSITION FROM '1' TO '0')

Asserting CPU_STOP# pin stops all CPU outputs that are set to be stoppable after their next transition. When the SMBus CPU_STOP tri-state bit corresponding to the CPU output of interest is programmed to a '0', CPU output will stop CPU_True = High and CPU_Complement = Low. When the SMBus CPU_STOP# tri-state bit corresponding to the CPU output of interest is programmed to a '1', CPU outputs will be tri-stated.

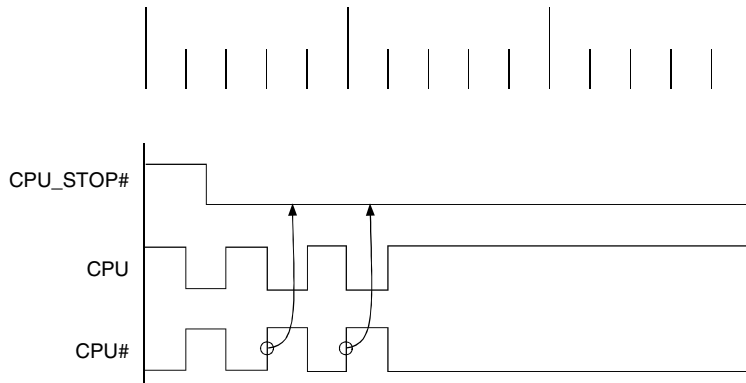

CPU_STOP# - DE-ASSERTION (TRANSITION FROM '0' TO '1')

With the de-assertion of CPU_STOP# all stopped CPU outputs will resume without a glitch. The maximum latency from the de-assertion to active outputs is two to six CPU clock periods. If the control register tristate bit corresponding to the output of interest is programmed to '1', then the stopped CPU outputs will be driven High within 10nS of CPU_STOP# de-assertion to a voltage greater than 200mV.

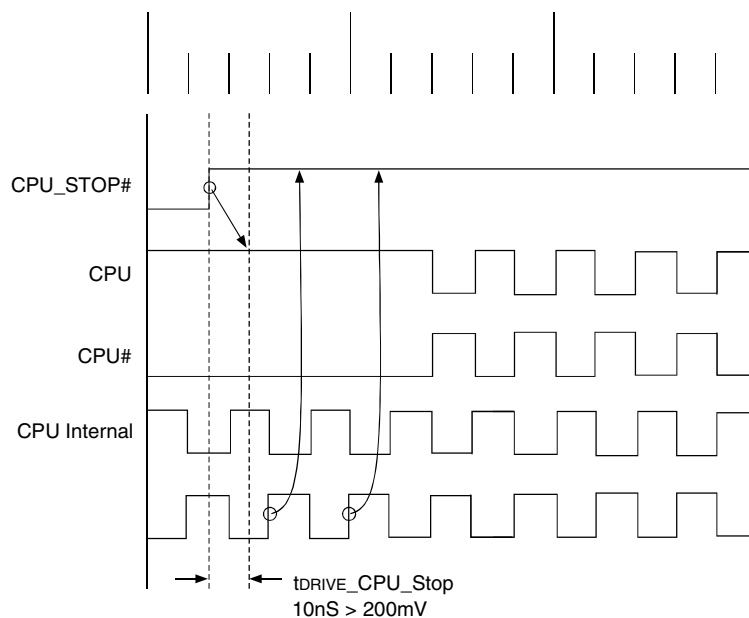

PD# ASSERTION

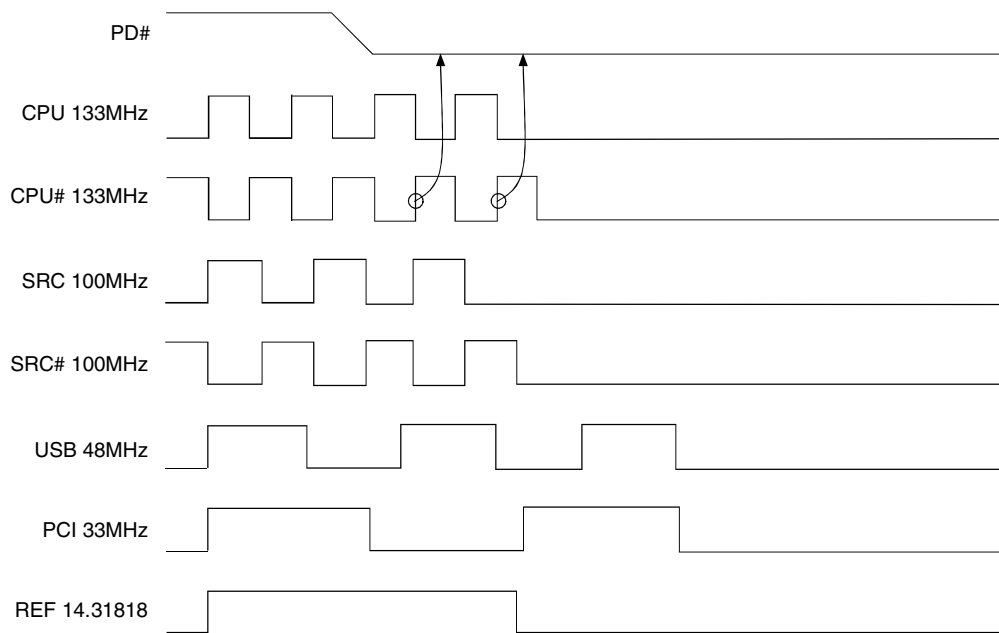

PD# DE-ASSERTION

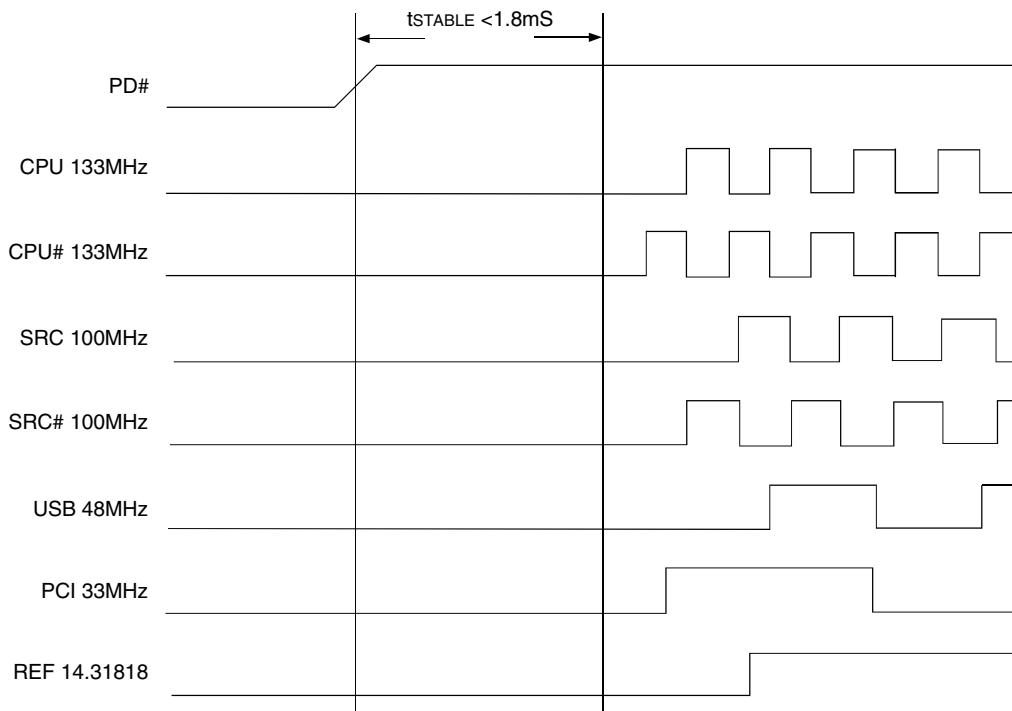

TSSOP PACKAGE DIMENSIONS

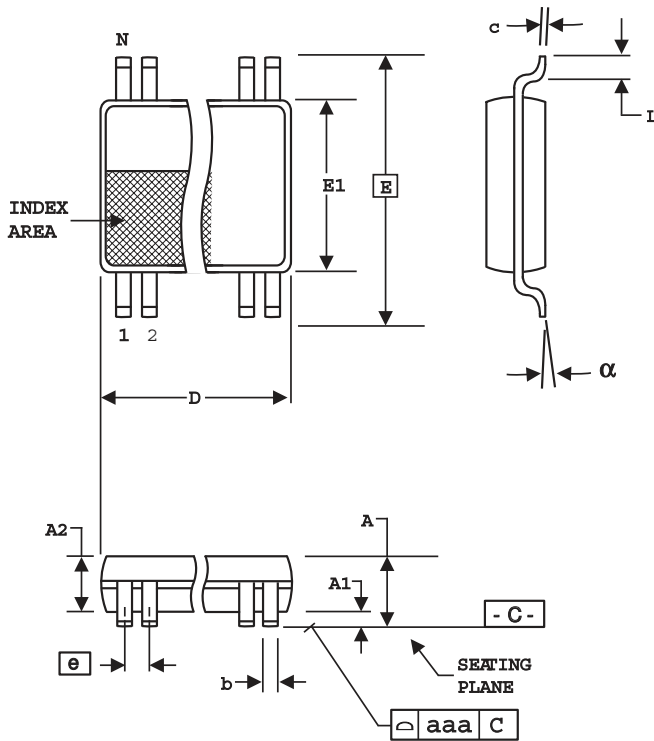

6.10 mm. Body, 0.50 mm. Pitch TSSOP
(240 mil) (20 mil)

| SYMBOL | In Millimeters | | In Inches | |
|--------|-------------------|-------------------|-------------------|-------------------|
| | COMMON DIMENSIONS | COMMON DIMENSIONS | COMMON DIMENSIONS | COMMON DIMENSIONS |
| A | -- | 1.20 | -- | .047 |
| A1 | 0.05 | 0.15 | .002 | .006 |
| A2 | 0.80 | 1.05 | .032 | .041 |
| b | 0.17 | 0.27 | .007 | .011 |
| c | 0.09 | 0.20 | .0035 | .008 |
| D | SEE VARIATIONS | | SEE VARIATIONS | |
| E | 8.10 BASIC | | 0.319 BASIC | |
| E1 | 6.00 | 6.20 | .236 | .244 |
| e | 0.50 BASIC | | 0.020 BASIC | |
| L | 0.45 | 0.75 | .018 | .030 |
| N | SEE VARIATIONS | | SEE VARIATIONS | |
| α | 0° | 8° | 0° | 8° |
| aaa | -- | 0.10 | -- | .004 |

VARIATIONS

| N | D mm. | | D (inch) | |
|----|-------|-------|----------|------|
| | MIN | MAX | MIN | MAX |
| 64 | 16.90 | 17.10 | .665 | .673 |

Reference Doc.: JEDEC Publication 95, MO-153

10-0039

ORDERING INFORMATION

IDTCV XXXX XXX XX X X
Device Type Revision Package T/R Grade

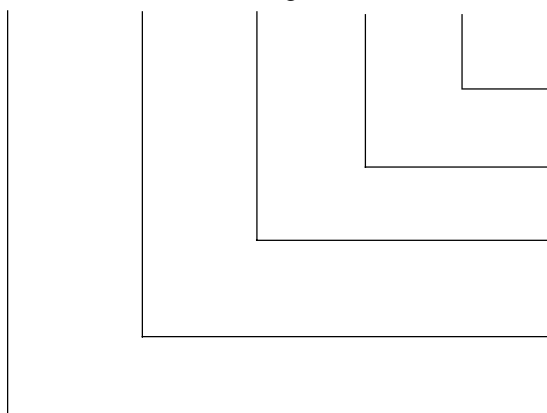

- Blank | Commercial Temperature Range (0°C to +70°C)
- 8 | Designation for tape and reel packaging
- PVG | Shrink Small Outline Package - Green
- PAG | Thin Shrink Small Outline Package - Green
- C | Revision Designator
- 193 | Programmable FlexPC Clock for P4 Processor

REVISION HISTORY

| | |
|-------------------|---|
| August 15, 2007 | Initial Release. |
| August 21, 2007 | Updated Pinout/Pin Description (pages 2-4). Added Sata_Sel Table (page 5). Updated SMBus (pages 7-12). |
| December 07, 2007 | Updated Byte 18 (pg. 12). |
| April 08, 2008 | Updated VDDxxx_IO supply voltage (pg. 13). |
| April 24, 2008 | Fixed Ordering Information (pg. 20). |
| June 24, 2008 | Added tape and reel ordering information (page 20) Corrected typo on pins 55 and 56 pin description (page 4) |
| October 20, 2008 | Updated Byte 1 (page 7). |
| April 8, 2009 | Updated Input/Supply Common Output Parameters table. |



CORPORATE HEADQUARTERS
6024 Silver Creek Valley Road
San Jose, CA 95138

for SALES:
800-345-7015 or 408-284-8200
fax: 408-284-2775
www.idt.com

for Tech Support:
pcclockhelp@idt.com