

DIMENSIONS (mm inch)

NEW

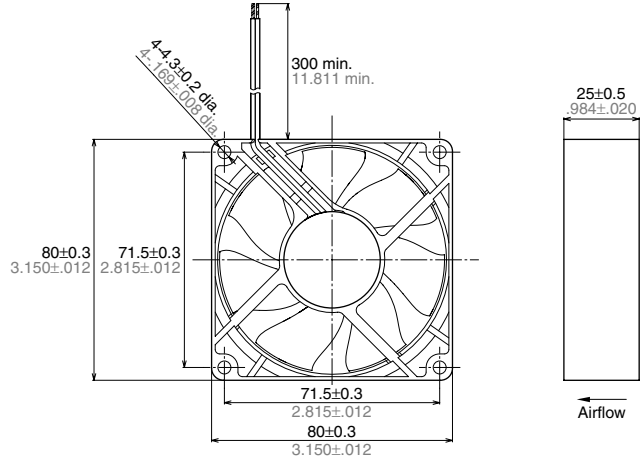

RoHS Directive compatibility information
<http://www.nais-e.com/>

RATING

1. Standard speed

Part number	Rated voltage (V)	Input power ^{*1/*2} (W)	Rated current ^{*1/*2} (mA)	Rotation speed (r/min)	Max. air flow (m ³ /min)	Max. static pressure (Pa)	Noise (dB(A))	Weight (g)
ASFN80371	12	3.96/3.00	330/250	2,950	1.09	36.6	32.5	80
ASFN80372	24	4.32/3.36	180/140					

2. Middle speed

Part number	Rated voltage (V)	Input power ^{*1/*2} (W)	Rated current ^{*1/*2} (mA)	Rotation speed (r/min)	Max. air flow (m ³ /min)	Max. static pressure (Pa)	Noise (dB(A))	Weight (g)
ASFN82371	12	2.04/1.56	170/130	2,400	0.88	24.3	27.0	80
ASFN82372	24	2.16/1.68	90/70					

3. Low speed

Part number	Rated voltage (V)	Input power ^{*1/*2} (W)	Rated current ^{*1/*2} (mA)	Rotation speed (r/min)	Max. air flow (m ³ /min)	Max. static pressure (Pa)	Noise (dB(A))	Weight (g)
ASFN84371	12	1.20/0.84	100/70	1,900	0.68	14.2	22	80
ASFN84372	24	1.44/0.96	60/40					

Notes: 1. Values above without designations are averages.

2. Noise levels are based on measurements taken at a distance of 1 m from the front of the fan.

*1: Designates maximum values

*2: Designates average values

DATA (Airflow - Static pressure Characteristic Curve)

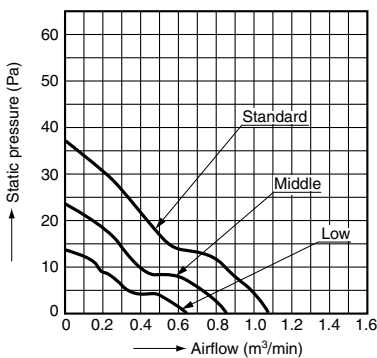

MATERIALS USED

Frame: plastic
Propeller: plastic
Bearings: ball bearings
Lead wires: UL1007 and AWG24

WIRING DIAGRAM

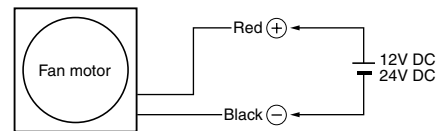

SPECIFICATIONS

Ambient temperature	-10°C to +60°C +14°F to +140°F	
Ambient humidity	15 to 85% RH	
Temperature rise	Coil surface: Max. 50 °C 122°F (Nominal voltage, by resistive method) External surface: Max. 20°C 68°F (Nominal voltage, by thermocouple method)	
Breakdown voltage	500 V AC for 1 min. (between lead wire and external housing)	
Insulation resistance	Min. 10 MΩ (at 500 V DC)	
Vibration resistance	Frequency	10 to 55Hz
	Double amplitude width	0.75mm
	Applied direction	X, Y and Z directions
	Applied time	10 min. in each direction
Lead wire tensile strength	9.8 N, single wires did not break at 15 seconds	
Fan blockage	No coil burnout even after blockage of 72 hrs. at nominal voltage.	
Reverse polarity power connection	No damage even after reverse polarity connection for short time at nominal voltage.	
Expected life	90% survival rate at 60,000 hrs. (When rotation frequency drops 30% of initial value when run at nominal voltage under 25°C 77°F, room humidity.)	