

# EiceDRIVER™

High voltage gate driver IC

## Evaluation Board

Application Note

EVAL\_6EDL04N02PR

## Application Note

Revision 1.0, 2013-07-26

**Edition 2013-07-26**

**Published by  
Infineon Technologies AG  
81726 Munich, Germany**

**© 2013 Infineon Technologies AG  
All Rights Reserved.**

#### **LEGAL DISCLAIMER**

THE INFORMATION GIVEN IN THIS APPLICATION NOTE IS GIVEN AS A HINT FOR THE IMPLEMENTATION OF THE INFINEON TECHNOLOGIES COMPONENT ONLY AND SHALL NOT BE REGARDED AS ANY DESCRIPTION OR WARRANTY OF A CERTAIN FUNCTIONALITY, CONDITION OR QUALITY OF THE INFINEON TECHNOLOGIES COMPONENT. THE RECIPIENT OF THIS APPLICATION NOTE MUST VERIFY ANY FUNCTION DESCRIBED HEREIN IN THE REAL APPLICATION. INFINEON TECHNOLOGIES HEREBY DISCLAIMS ANY AND ALL WARRANTIES AND LIABILITIES OF ANY KIND (INCLUDING WITHOUT LIMITATION WARRANTIES OF NON-INFRINGEMENT OF INTELLECTUAL PROPERTY RIGHTS OF ANY THIRD PARTY) WITH RESPECT TO ANY AND ALL INFORMATION GIVEN IN THIS APPLICATION NOTE.

#### **Information**

For further information on technology, delivery terms and conditions and prices, please contact the nearest Infineon Technologies Office ([www.infineon.com](http://www.infineon.com)).

#### **Warnings**

Due to technical requirements, components may contain dangerous substances. For information on the types in question, please contact the nearest Infineon Technologies Office.

Infineon Technologies components may be used in life-support devices or systems only with the express written approval of Infineon Technologies, if a failure of such components can reasonably be expected to cause the failure of that life-support device or system or to affect the safety or effectiveness of that device or system. Life support devices or systems are intended to be implanted in the human body or to support and/or maintain and sustain and/or protect human life. If they fail, it is reasonable to assume that the health of the user or other persons may be endangered.



---

**Revision History: 2013-07 Rev.1.0**

Page or Item	Subjects (major changes since last revision)
--------------	--

**Previous Version: 1.0**

---

**Trademarks of Infineon Technologies AG**

AURIX™, C166™, CanPAK™, CIPOS™, CIPURSE™, EconoPACK™, CoolMOS™, CoolSET™, CORECONTROL™, CROSSAVE™, DAVE™, DI-POL™, EasyPIM™, EconoBRIDGE™, EconoDUAL™, EconoPIM™, EconoPACK™, EiceDRIVER™, eupec™, FCOS™, HITFET™, HybridPACK™, I<sup>2</sup>RF™, ISOFACE™, IsoPACK™, MIPAQ™, ModSTACK™, my-d™, NovalithIC™, OptiMOS™, ORIGA™, POWERCODE™, PRIMARION™, PrimePACK™, PrimeSTACK™, PRO-SIL™, PROFET™, RASIC™, ReverSave™, SatRIC™, SIEGET™, SINDRION™, SIPMOS™, SmartLEWIS™, SOLID FLASH™, TEMPFET™, thinQ!™, TRENCHSTOP™, TriCore™.

**Other Trademarks**

Advance Design System™ (ADS) of Agilent Technologies, AMBA™, ARM™, MULTI-ICE™, KEIL™, PRIMECELL™, REALVIEW™, THUMB™, μVision™ of ARM Limited, UK. AUTOSAR™ is licensed by AUTOSAR development partnership. Bluetooth™ of Bluetooth SIG Inc. CAT-iq™ of DECT Forum. COLOSSUS™, FirstGPS™ of Trimble Navigation Ltd. EMV™ of EMVCo, LLC (Visa Holdings Inc.). EPCOS™ of Epcos AG. FLEXGO™ of Microsoft Corporation. FlexRay™ is licensed by FlexRay Consortium. HYPERTERMINAL™ of Hilgraeve Incorporated. IEC™ of Commission Electrotechnique Internationale. IrDA™ of Infrared Data Association Corporation. ISO™ of INTERNATIONAL ORGANIZATION FOR STANDARDIZATION. MATLAB™ of MathWorks, Inc. MAXIM™ of Maxim Integrated Products, Inc. MICROTEC™, NUCLEUS™ of Mentor Graphics Corporation. MIPI™ of MIPI Alliance, Inc. MIPS™ of MIPS Technologies, Inc., USA. muRata™ of MURATA MANUFACTURING CO., MICROWAVE OFFICE™ (MWO) of Applied Wave Research Inc., OmniVision™ of OmniVision Technologies, Inc. Openwave™ Openwave Systems Inc. RED HAT™ Red Hat, Inc. RFMD™ RF Micro Devices, Inc. SIRIUS™ of Sirius Satellite Radio Inc. SOLARIS™ of Sun Microsystems, Inc. SPANSION™ of Spansion LLC Ltd. Symbian™ of Symbian Software Limited. TAIYO YUDEN™ of Taiyo Yuden Co. TEAKLITE™ of CEVA, Inc. TEKTRONIX™ of Tektronix Inc. TOKO™ of TOKO KABUSHIKI KAISHA TA. UNIX™ of X/Open Company Limited. VERILOG™, PALLADIUM™ of Cadence Design Systems, Inc. VLYNQ™ of Texas Instruments Incorporated. VXWORKS™, WIND RIVER™ of WIND RIVER SYSTEMS, INC. ZETEX™ of Diodes Zetex Limited.

Last Trademarks Update 2011-11-11

## Table of Contents

<b>1</b>	<b>Introduction .....</b>	<b>5</b>
<b>2</b>	<b>Design feature .....</b>	<b>6</b>
2.1	Main features.....	6
2.2	Key data .....	7
2.3	Pin assignment.....	8
<b>3</b>	<b>Electrical features .....</b>	<b>9</b>
3.1	Supply voltage +15V .....	9
3.2	Under voltage lockout .....	9
3.3	Over-current detection .....	9
3.4	MOSFET turn - on / off .....	10
3.5	DC-Link capacitor.....	12
3.6	Input Signals.....	12
<b>4</b>	<b>Schematic and Layout .....</b>	<b>13</b>
4.1	Schematic.....	13
4.2	Layout.....	16
4.2.1	Layout top.....	16
4.2.2	Layout bottom.....	16
4.2.3	Top place.....	17
4.3	Bill of material .....	18

#### Warnings



The described board is an evaluation board dedicated for laboratory environment only. It operates at high voltages. This board must be operated by qualified, skilled personnel familiar with all applicable safety standards.

## 1 Introduction

The gate driver evaluation board EVAL\_6EDL04N02PR was developed to show the functionalities and key features of the Infineon MOSFET gate driver 6EDL04N02PR.

The board is available from Infineon in sampling quantities. The properties of this part are described in the datasheet chapter of this document, whereas the remaining paragraphs provide information intended to enable the customer to copy, modify and qualify the design for production, according to their own specific requirements.

The design of the EVAL\_6EDL04N02PR was performed with respect to the environmental conditions described in this document. The design was tested as described in this document, but not qualified regarding manufacturing, lifetime or over the full ambient operating conditions.

The boards provided by Infineon are subjected to functional testing only.

Due to their purpose Evaluation Boards are not subjected to the same procedures regarding Returned Material Analysis (RMA), Process Change Notification (PCN) and Product Discontinuation (PD) as regular products. These Evaluation Boards are used for development support only and should not be used as reference design for volume production.

See Legal Disclaimer and Warnings for further restrictions on Infineons warranty and liability.

## 2 Design feature

This chapter provides an overview of the main features, key datas, pin assignments and mechanical dimensions

### 2.1 Main features

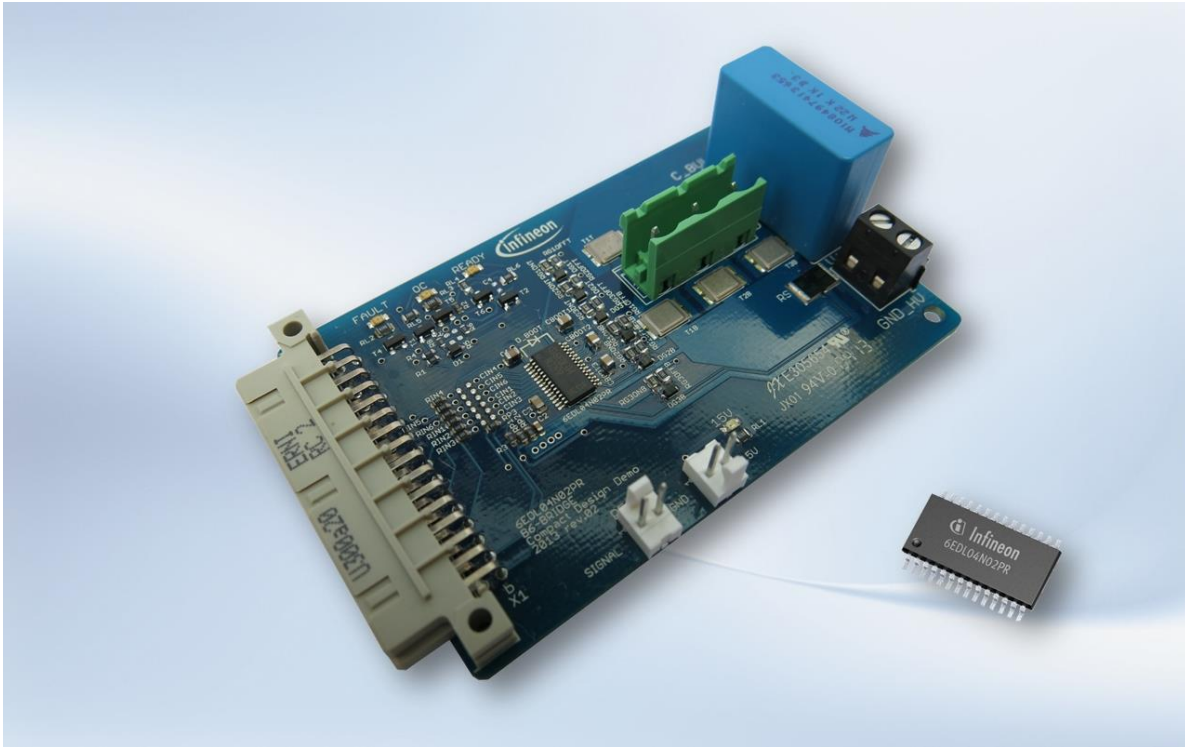

Figure 2-1 top view of the EVAL\_6EDL04N02PR

The EVAL\_6EDL04N02PR contains an Infineon MOSFET full bridge gate driver 6EDL04N02PR in TSSOP package and six Infineon MOSFETs BSB044N08NN3G.

The evaluation board provides the following main features

- Over-current detection with shunt voltage measurement, latch and reset functionality
- Under voltage lock out
- Bootstrap functionality for high side MOSFETs
- Use of the Internal ultra fast bootstrap diodes of the 6EDL04N02PR
- 15V supply, Reset, High voltage supply, external load
- Status LED for 15V supply, ready, fault and overcurrent status
- DC link capacitor

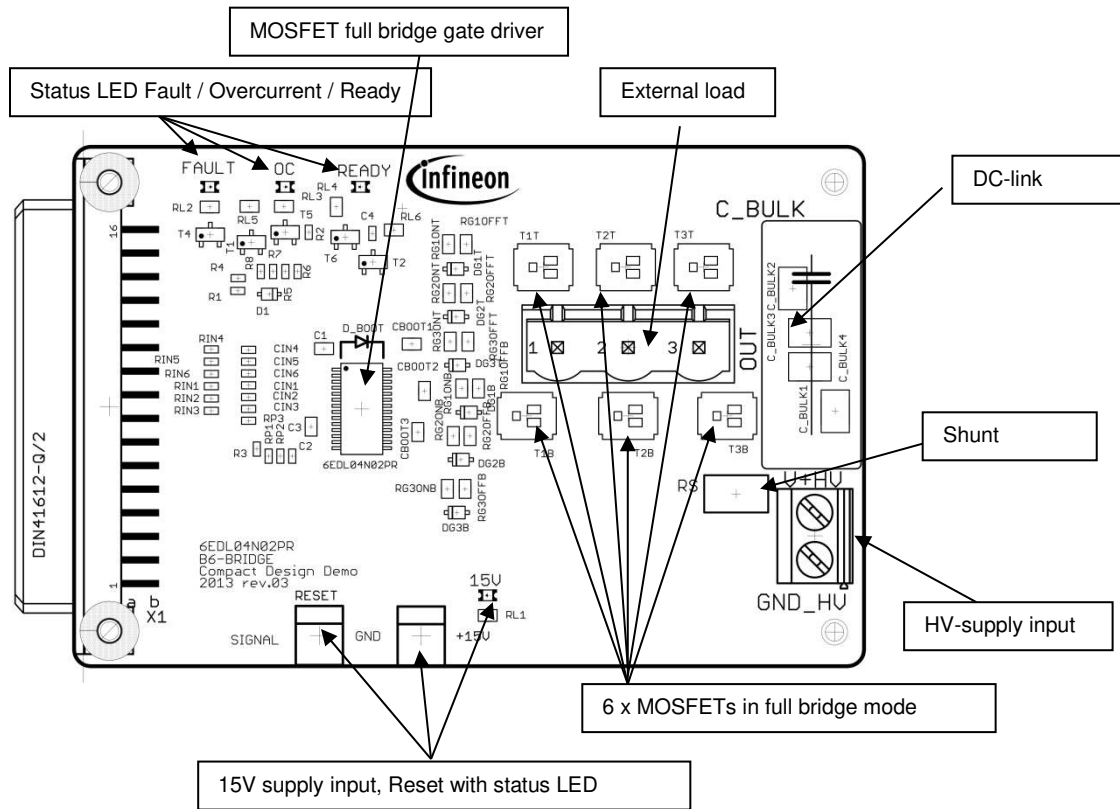

Figure 2-2 overview functionalities on top-side

## 2.2 Key data

All values are values at an ambient temperature of 25°C.

Table 2-1

Parameter	Description	Typ.	Min.	Max.	Unit
<b>+15V</b>	15V voltage supply	13.5	10	17.5	V
<b>HV</b>	High voltage supply	-	-	80	V
<b>I<sub>Out</sub></b>	Output current	-	-	10	A
<b>f<sub>p</sub></b>	Switching frequency	20	-	200	kHz
<b>R<sub>Gmin_on</sub></b>	Min. gate resistor to limit gate driver output at turn on	-	73	-	Ω
<b>R<sub>Gmin_off</sub></b>	Min. gate resistor to limit gate driver output at turn off	-	42	-	Ω

\* Please make sure that the maximum rated values never get exceeded. Also the performance and quality can not be guaranteed when using the board with all parameters in maximum rated value at the same time.

## 2.3 Pin assignment

Table 2-2

Connector name	Pin no.	Pin name	Description
RESET	Left terminal	/RST	
	Right terminal	GND	

+15V (VDD)	Right terminal	+15V	positive 15V supply
	Left terminal	GND	

X1	B1	EN	input – 0V to disable circuit, integrated pull up
	B2	/FLT	open drain output with pull up to 15V
	B3	HIN3	non-inverting input T3T IGBT; 0V off, 5V on
	B4	LIN3	non-inverting input T3B IGBT; 0V off, 5V on
	B5	HIN2	non-inverting input T2T IGBT; 0V off, 5V on
	B6	LIN2	non-inverting input T2B IGBT; 0V off, 5V on
	B7	HIN1	non-inverting input T1T IGBT; 0V off, 5V on
	B8	LIN1	non-inverting input T1B IGBT; 0V off, 5V on
Please reference all input signals to the GND of the 15V supply			

GND_HV			reference for high voltage supply (Power-GND, internally connected to GND)
V+HV			positive high voltage supply (up to 400V related to GND_HV)
OUT			Output HV 3phase bridge (related to GND_HV)



## 3 Electrical features

### 3.1 Supply voltage +15V

The supply voltage for the digital part and for the driver output (+15V VCC) has to be supplied externally over the dedicated connector. The evaluation board does not provide an over voltage supply monitoring, therefore the user has to ensure that the voltages are in the correct range. Voltages above the max. values will lead to damages of the MOSFET driver. The availability of the supply voltages is visible over the green status LEDs.

The high-Side gate driver outputs are supplied over internal bootstrap diodes and the bootstrap capacitors CBOOT1,2,3. To ensure that the bootstrap capacitor is charged before the high side MOSFET is switched on, the low side MOSFET has to be switched on for a dedicated time.

### 3.2 Under voltage lockout

The +15V supply VCC is monitored by the 6EDL04N02PR. In case of an undervoltage the driver output is switched off. The thresholds are typically  $V_{CCUV+} = 9\text{ V}$  (positive going) and  $V_{CCUV-} = 8.1\text{ V}$  (negative going). This status is visible over the red FAULT LED. If the FAULT LED is on and the OC LED is off, an undervoltage is detected.

### 3.3 Over-current detection

The 6EDL04N02PR provides an over-current detection function by connecting the ITRIP input with the load feedback current. The shunt voltage drop is connected to the ITRIP comparator which has a threshold of typically 0.44V.

With the Shunt resistor value of 20mOhm the ITRIP is triggered at a current of typically 22A.

The over-current event generates a hard shut down of all gate driver outputs and provides a latched fault feedback at /FAULT pin and the capacitor at pin RCIN will be discharged. The fault is latched till the capacitor at RCIN is re-charged and the voltage level reaches a value of typically 5.2V.

In the EVAL\_6EDL04N02PR a logic keeps the capacitor at RCIN discharged till a LOW pulse at the RESET pin occurs.

An over-current event is shown by the LED "OC" and LED "FAULT" together.

At power up the logic has an undefined state. If only the LED "OC" is on after power up it is recommend to reset the logic with a LOW pulse at RESET.

The shunt resistor value may be adjusted, when operating the board with different HV supply voltage in order to guarantee a proper detection of short circuit events.

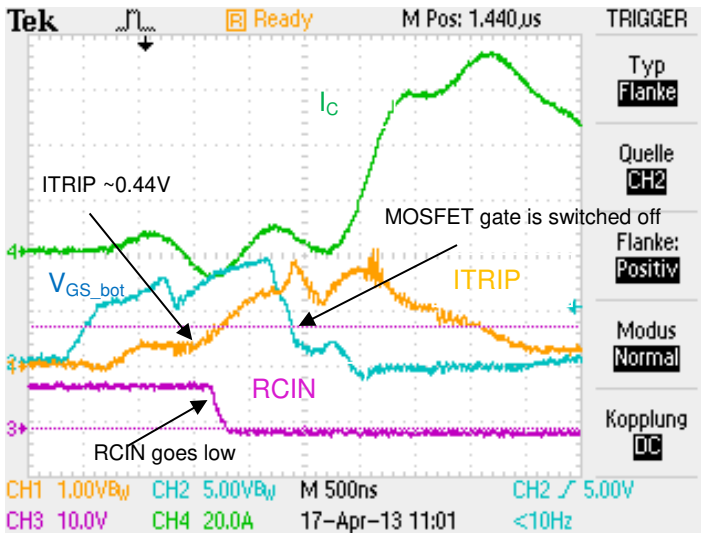

**Figure 3-1** over-current detection signals during shoot through (Ic curve with 1.2µs delay due to slow current probe)

### 3.4 MOSFET turn - on / off

The switching characteristic of the MOSFETs is defined by the gate resistors RGxONT, RGxONB, RGxOFFT, RGxOFFB and the diodes DGxT and DGxB. Where “x” means 1,2,3 for the three output stages.

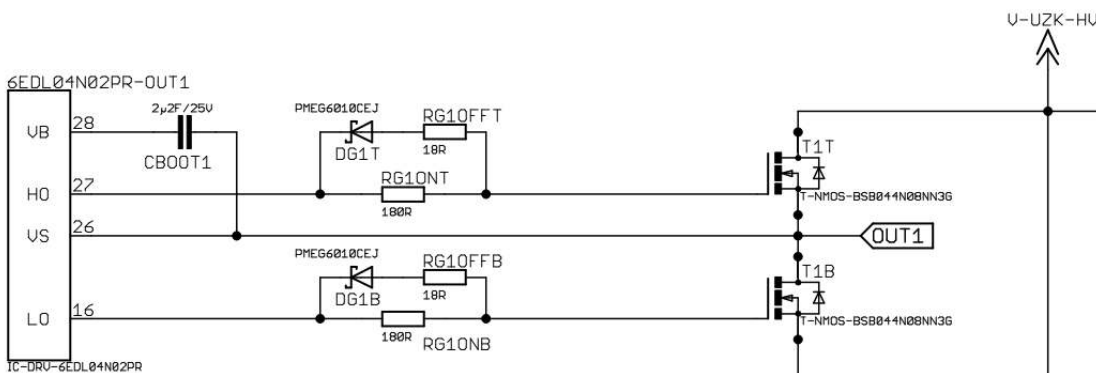

**Figure 3-2** gate driver output of the 6EDL04N02PR. Exemplarily only output 1 pictured

The gate resistors are adapted to the max. gate driver output current of the 6EDL04N02PR for turn-on and turn-off. There is the possibility to adapt the switching characteristic to specific applications or to different MOSFETs by replacing the resistor values. The use of RGxOFFT and RGxOFFB together with DGxT and DGxB makes it possible to change the on-switching and the off-switching slopes of the MOSFET independent to each other.

To avoid a shoot through between top- and bottom MOSFET, the operator needs ensure sufficient dead time. With this setup the deadtime should be > 0.5µs.

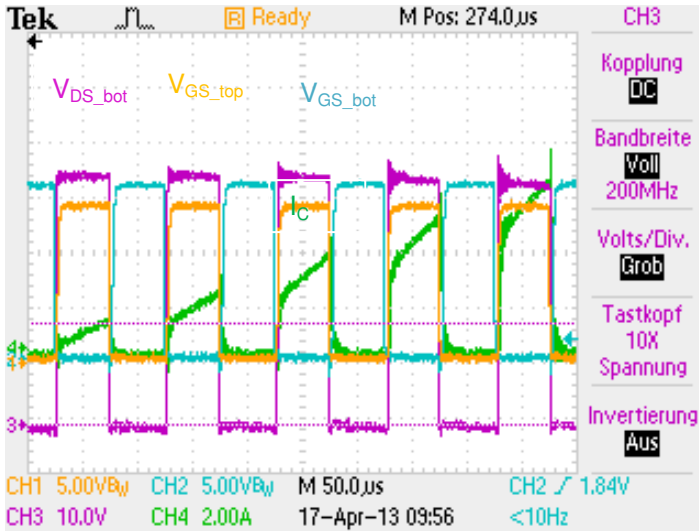

Figure 3-3 switching sequence

Switching sequence with 5 pulses and the following parameters:

Supply Input: 45V  
Duty cycle = 50% referred to the top MOSFET  
Load = R/L with about 1700µH and 2.30mΩ  
Load connected between OUT and GND\_HV

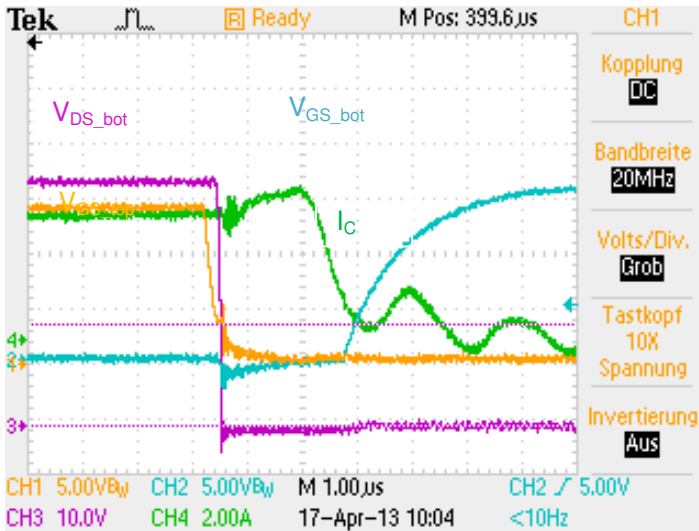

Figure 3-4 turning off top MOSFET with 2.5µs dead time

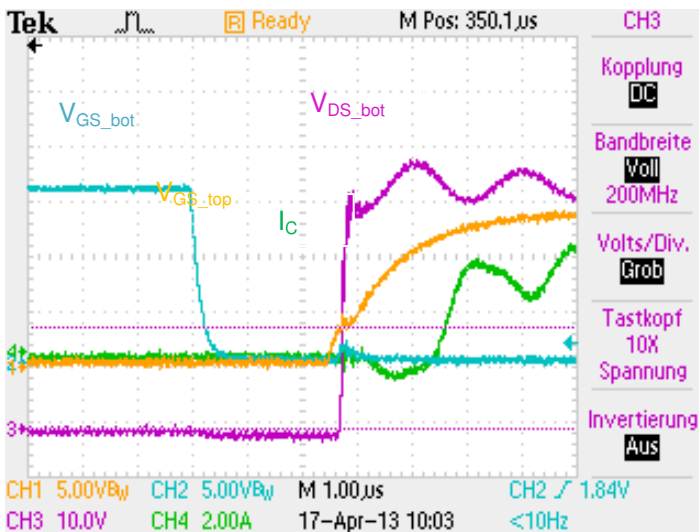

Figure 3-5 turning on top MOSFET with 2.5µs dead time

### 3.5 DC-Link capacitor

Due to the available space there is only a small DC-Link capacitor of 220nF available. If a bigger DC-Link capacity is necessary it has to be connected externally to the connectors V+HV and GND\_HV.

### 3.6 Input Signals

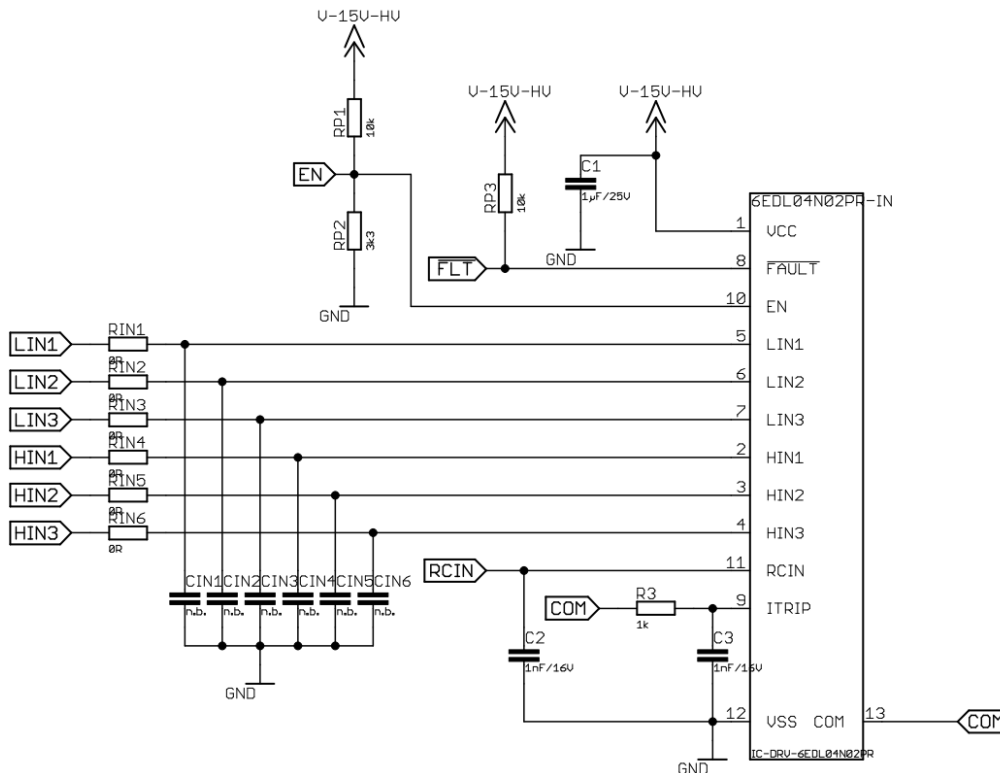

Figure 3-6 Driver input Signals

There is the possibility to use low pass filters inside the PWM input signals LIN1,2,3 and HIN1,2,3 to avoid an undesired switch on a MOSFET by disturbances. This feature is not used in this evaluation board, but there is the possibility to test it by changing the resistors RIN1,2,3,4,5,6 and the capacitors CIN1,2,3,4,5,6.

## 4 Schematic and Layout

### 4.1 Schematic

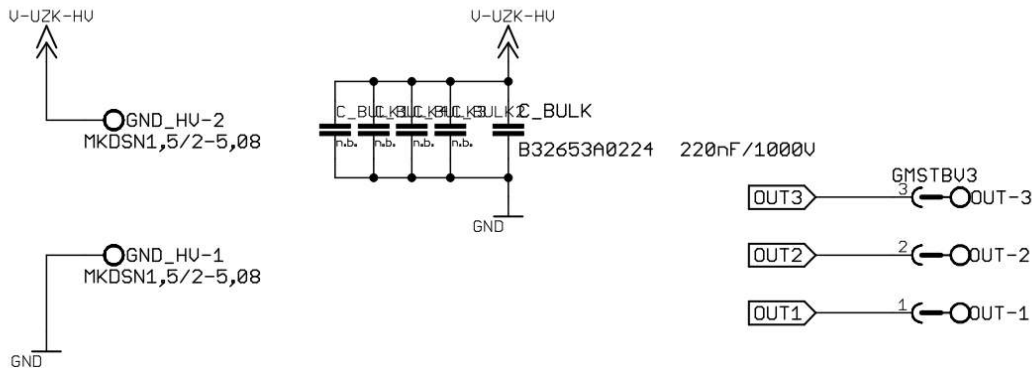

Figure 4-1 HV supply input, DC-Link and load connector

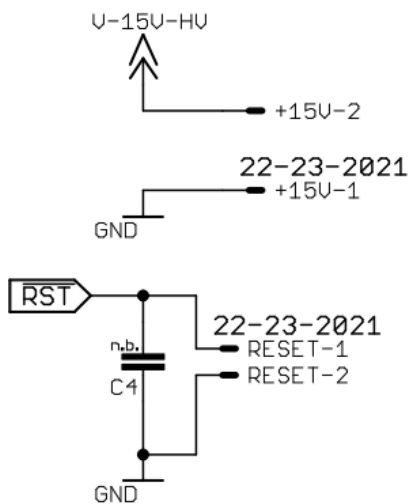

Figure 4-2 LV Supply and Reset Input

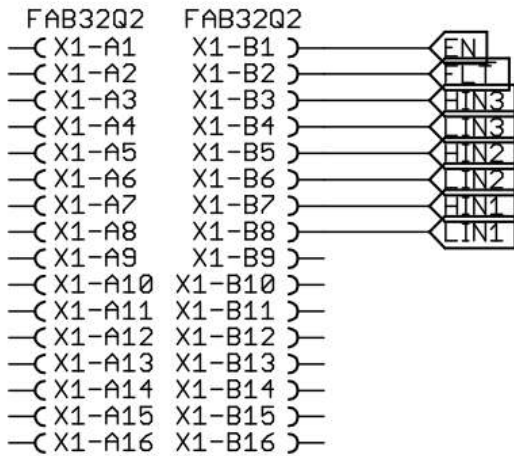

Figure 4-3 connector X1

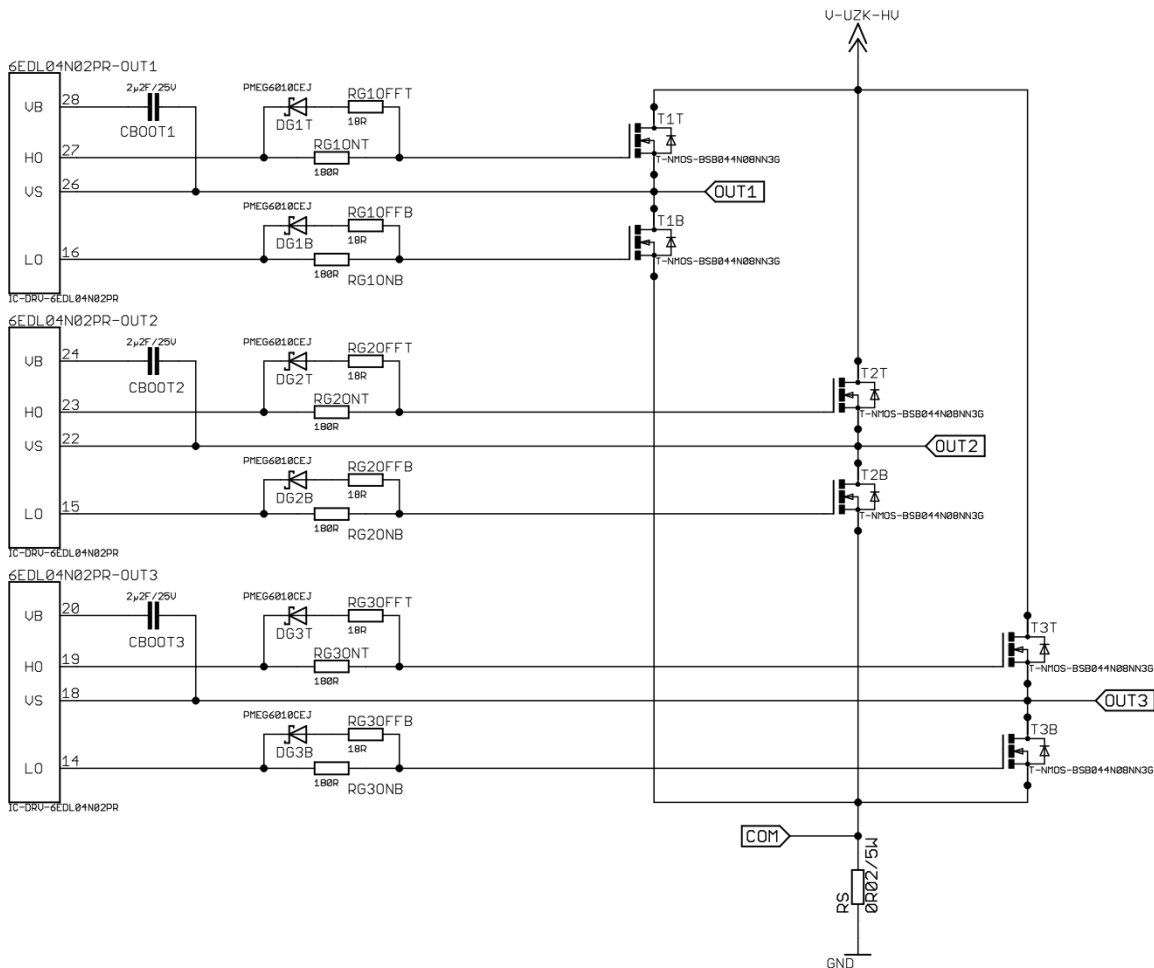

Figure 4-4 Infineon driver 6EDL02N04PR output

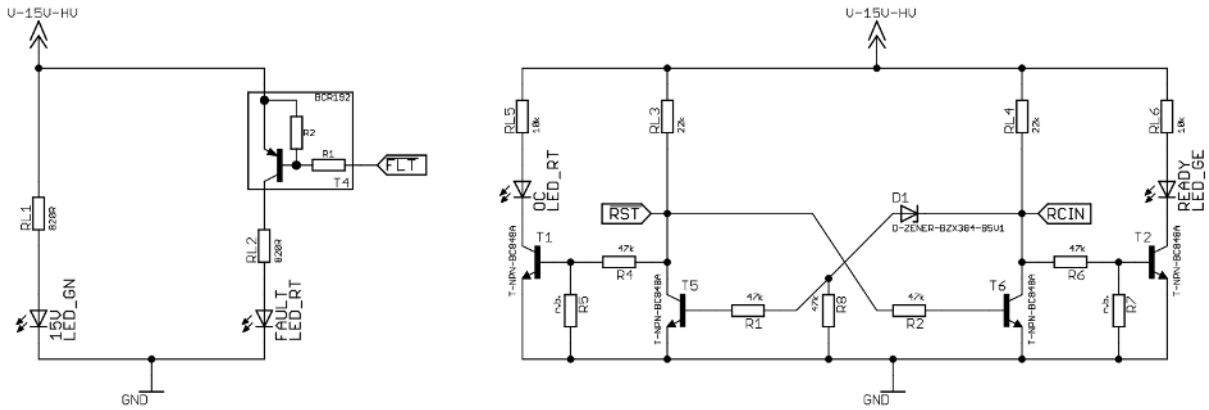

Figure 4-5 LEDs, FAULT and READY logic

## 4.2 Layout

### 4.2.1 Layout top

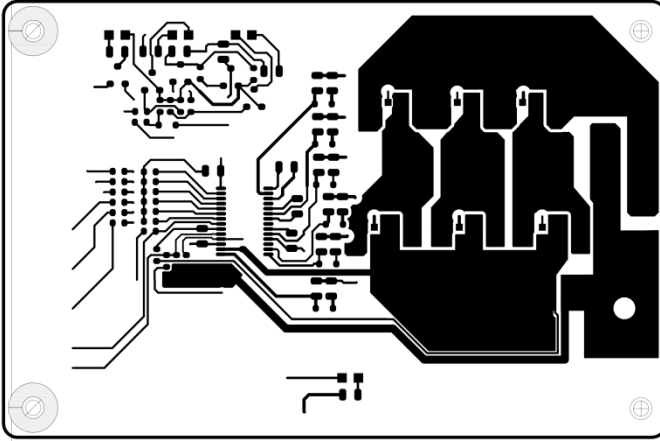

Figure 4-6 Layout top of the 6EDL02N04PR\_EVAL

### 4.2.2 Layout bottom

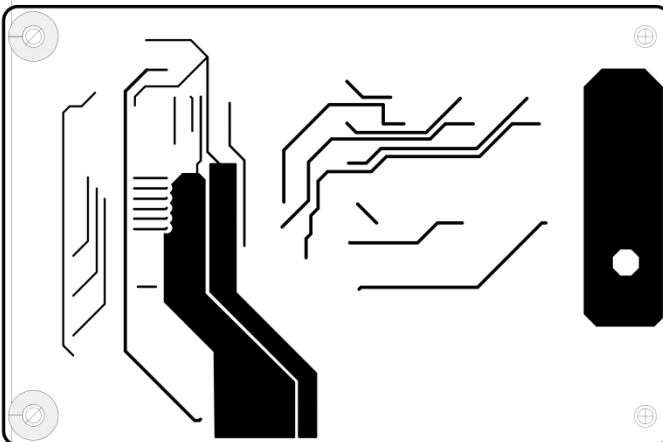

Figure 4-7 Layout bottom of the 6EDL02N04PR\_EVAL



### 4.2.3 Top place

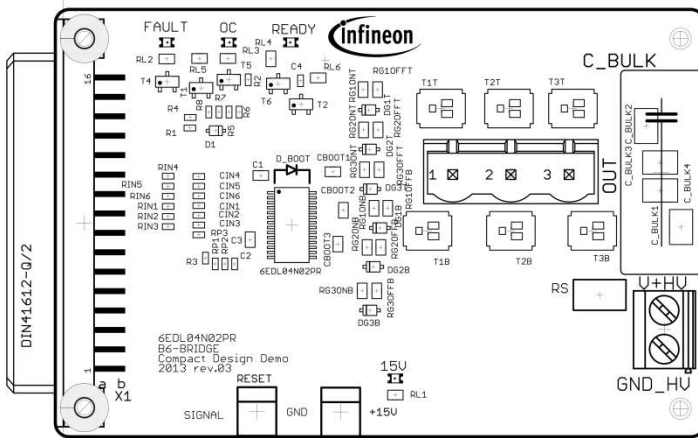

Figure 4-8 top place view of the 6EDL02N04PR\_EVAL

### 4.3 Bill of material

Part	Value	Package
C1	1μF/25V	SMD0805
C2	1nF/16V	SMD0603
C3	1nF/16V	SMD0805
CBOOT1, CBOOT2, CBOOT3	2μF/25V	SMD0805
C_BULK	220nF/1000V	C22.5B10
D1	D-ZENER-BZX384-C5V1	SOD323
DG1B, DG1T, DG2B, DG2T, DG3B, DG3T	PMEG6010CEJ	SOD323F
R1, R2, R4, R6, R8	47k	SMD0603
R3	1k	SMD0603
RG1OFFB, RG1OFFT, RG2OFFB, RG2OFFT, RG3OFFB, RG3OFFT	18R	SMD0805
RG1ONB, RG1ONT, RG2ONB, RG2ONT, RG3ONB, RG3ONT	180R	SMD0805
RIN1, RIN2, RIN3, RIN4, RIN5, RIN6	0R	SMD0603
RL1, RL2	820R	SMD0805
RL3, RL4	22k	SMD0805
RL5, RL6	10k	SMD0805
RP1, RP3	10k	SMD0603
RP2	3k3	SMD0603
RS	0R02/5W	SMT-REF
6EDL04N02PR	IC-DRV-6EDL04N02PR	PG-TSSOP-28
T1, T2, T5, T6	T-NPN-BC848A	SOT23
T1B, T1T, T2B, T2T, T3B, T3T	T-NMOS-BSB044N08NN3G	CANPAK_MG-WDSO-2
T4	BCR192	SOT23
X1	FAB32Q2	FAB32Q2
+15V, RESET	22-23-2021	22-23-2021
GND_HV	MKDSN1,5/2-5,08	MKDSN1,5/2-5,08
OUT	GMSTBV3	GMSTBV3
FAULT, OC	LED_RT	CHIPLED_0805
15V	LED_GN	CHIPLED_0805
READY	LED_GE	CHIPLED_0805

[www.infineon.com](http://www.infineon.com)

Published by Infineon Technologies AG